

# Germain Honda of College Hills



## INSTALLATION INSTRUCTIONS

Accessory

18" ALUMINUM WHEEL

Application

2020 RIDGELINE MODEL  
SERIES

Publications No.

VERSION 1

Issue Date

JUL 2022

## GENERAL VIEW

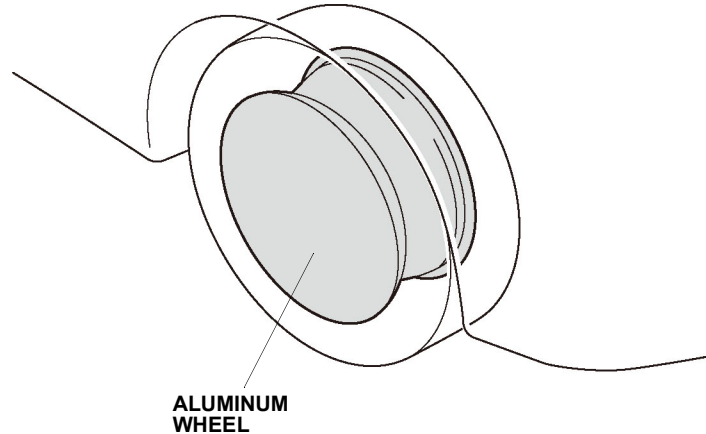

Q0N0101AJ

## FOR YOUR SAFETY (Read carefully.)

### Warning Symbols

**Safety:** Your safety, and the safety of others, is important. To help you make informed decisions about service procedures, we have provided safety messages where appropriate. Of course, it is not practical or possible to warn you about all the hazards associated with servicing a vehicle - you must use your own good judgment.

You will find important safety messages preceded by one of following symbols:

\*All symbols are not used in all installation instructions.

 **DANGER**

You will be killed or seriously hurt if you do not follow the instructions.

 **WARNING**

You can be killed or seriously hurt if you do not follow the instructions.

 **CAUTION**

You can be hurt if you do not follow the instructions.

**NOTICE**

Gives advice to prevent damage to the product or vehicle or the environment.

**NOTE**

Gives helpful information or instructions to be followed when using the product.



Indicates a prohibited action

# Germain Honda of College Hills

## Procedure and Location Icons

These icons indicate the work location and the worker's point of view.

\*All icons are not used in all installation instructions.

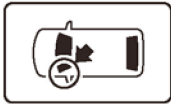

The location on the vehicle.

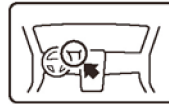

The location in the vehicle.  
(instrument panel.)



Wear eye protection.



Wear heavy gloves.



Use an assistant.



Place the part on a blanket.



Work perpendicular.



Remove any burrs.



Use touch-up paint and allow to dry.



Tighten to the specified torque.



Apply firm pressure while rolling, especially at the ends, to set the adhesive.



Press firmly.



Clean with isopropyl alcohol.



Return the original part to the customer.  
(Do not use.)

## Safety: General

- Observe all safety notes and precautions described in the service information, in addition to those described in this Installation Instruction. Be extremely careful for your safety and safety of others.
- Always use the tire changer when installing or removing tires. See the Owner's Manual for reference.
- When using wheel balancer, refer to the Owner's Manual of used machinery.
- Be careful not to damage the vehicle or the parts.
- The illustrations may differ slightly from the actual accessory.

# Germain Honda of College Hills

## Safety: Accessory

- The illustration is an example. It may differ from the actual parts such as shapes.
- Always install the correct sized tires specified in the tire pressure caution plate.
- Always use the specified wheel nuts and wheel lock nuts.
- The standard wheel nuts may not be used with the aluminum wheels. Replace them with the correct wheel nuts which are sold separately as described below.
- Always use the parts and tools specified in the installation instructions.
- Do not install the accessory on a dirty surface or in direct sunlight.
- Make sure the ambient air temperature is 60°F (15°C) or above when installing accessories that use a bonding material.
- When pressing the accessory firmly with the palm of your hand, be careful not to damage it or the vehicle.
- When applying adhesive material, make sure it is lined up properly before attaching. Once the adhesive material touches the surface, do not try to remove it. If you do, you could damage the part before the adhesive releases.
- Not to wash the vehicle or moisten it for 24 hours to allow the adhesive to cure.

## PARTS LIST

### Aluminum Wheel Kit





(P/N 08W18-T6Z-100A)

(P/N 08W18-T6Z-100B)

(P/N 08W18-T6Z-100C)

(P/N 08W18-T6Z-P00B)

(\*: The part differs depending on the kit.)

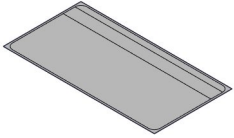
<p>Aluminum wheel (The illustration may differ from the actual wheel.)</p>  <p>TPMS sensor (Sold separately.)</p> 	<p>*Wheel center cap (The illustration may differ from the actual center cap.) (P/N 08W18-T6Z-100A)</p> 	<p>*Wheel center cap (The illustration may differ from the actual center cap.) (P/N 08W18-T6Z-100B) (P/N 08W18-T6Z-100C) (P/N 08W18-T6Z-P00B)</p> 	<p>Wheel cleaning information</p> 
--	---	--	---

## REQUIRED TOOLS AND SUPPLIES

- Ratchet
- Lubricant
- 22 mm Socket
- Valve insert tool
- Torque wrench

# Germain Honda of College Hills

## SPECIFICATIONS

Rim size	18 x 8J (inset 45)	
Tire size	245/60R18 105H	
Bolt hole PCD	120 (5 holes)	
Tire pressure	Front	35 psi (240 kPa)
	Rear	35 psi (240 kPa)

# Germain Honda of College Hills

## INSTALLATION

Using isopropyl alcohol and a shop towel, thoroughly clean the surface where the accessory adhesive will attach.

### NOTE

- Always use isopropyl alcohol where you see this symbol.
- Do not pour isopropyl alcohol directly on the vehicle surface.
- Let the isopropyl alcohol completely evaporate before attaching the adhesive material.



### NOTE

- This aluminum wheel is designed for use on a vehicle equipped with a tire pressure monitoring system (TPMS).
  - This aluminum wheel is equipped with a tire pressure sensor. See the service information for the tire replacement and sensor installation procedures.
  - The illustrations of the aluminum wheels are shown for reference purposes only.
  - Install the correct size tire.
  - Follow the instructions in the online owner's manual when raising the vehicle, and when removing and installing the wheels. Do not overtighten the wheel nuts.
- Wheel nut torque: 94 lb-ft (127 N·m)
- Use a tire changer to install and remove the tires according to the directions in the operation manual furnished with the tire changer. Do not use a tire lever to install and remove the tires as it may cause damage to the tire and aluminum wheel.

1. Apply lubricant or immerse.

### NOTE

Do not apply lubricant or immerse onto the housing assembly.

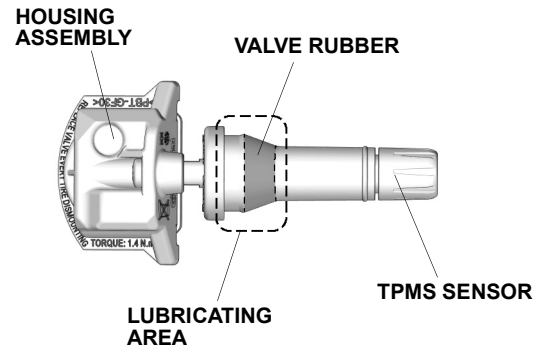

QH22103AH

2. Remove the valve cap.

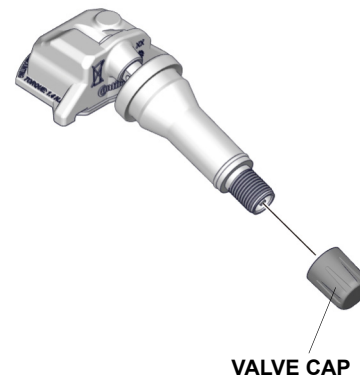

QH22104AH

# Germain Honda of College Hills

3. Clean the TPMS sensor and aluminum wheel.

## NOTE

- Clean the mating surface.
- Make sure to install the TPMS sensor in the correct direction.

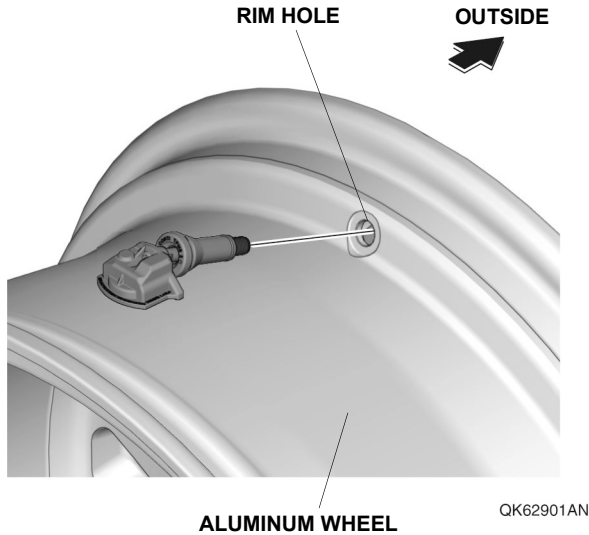

4. Insert the TPMS sensor.
5. Install the valve insert tool.

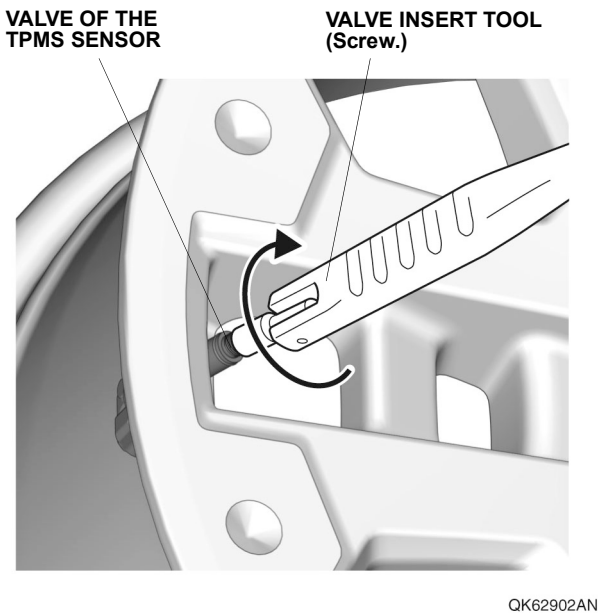

6. Pull the TPMS sensor valve.

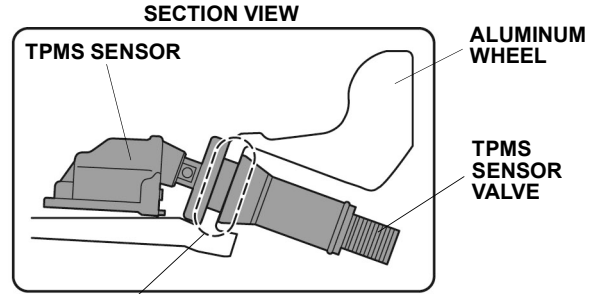

Make sure there is no gap in this area.

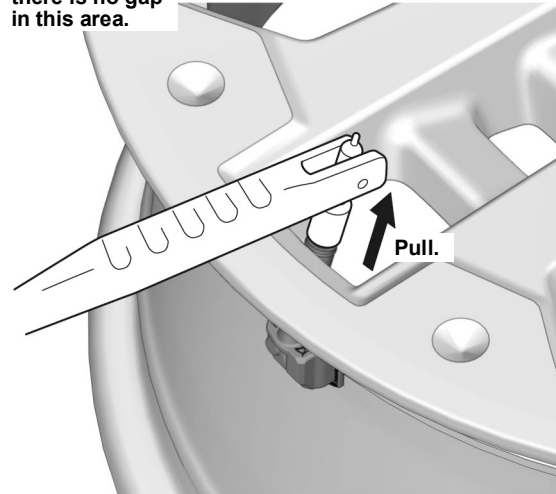

7. Install the valve cap.
8. Check the TPMS sensor.

## NOTE

Keep angle between the tangent of the rim drop-well and bottom surface of the housing within  $-10^{\circ}$  to  $+10^{\circ}$  after insertion.

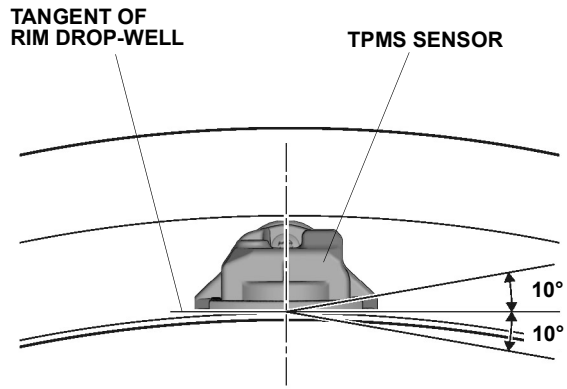

QJ80525AB

# Germain Honda of College Hills

9. Install the tires.

NOTE
<ul style="list-style-type: none"><li>• Check that there is no damage to the bead area.</li><li>• Use a lubricant to smoothly install the tires.</li><li>• Always adjust to the tire pressure specified in the tire pressure caution plate.</li></ul>



10. Install the wheels.

NOTE
Wheel nut torque: 94 lb-ft (127 N·m)

11. Drive the vehicle for at least 40 seconds at a speed of 15 mph (24 km/h) or more. All sensor IDs will be automatically memorized.

## USE AND CARE

- **Use a neutral detergent to clean the wheels.**
- **Rinse off the neutral detergent promptly after cleaning the wheels.**