



INSTALLATION INSTRUCTIONS

Accessory
SKID PLATE
 P/N 08P46-T6Z-100

Application
2020 RIDGELINE

Publications No.
VERSION 1
 Issue Date
NOV 2019

PARTS LIST

Skid plate



Skid plate base



Right air dam



Left air dam



2 Self-tapping screws



6 x 24 mm Bolt



2 Bolts, 6 x 40 mm



3 Rivet nuts



4 Shoulder bolts



3 Washers



TOOLS AND SUPPLIES REQUIRED

Phillips screwdriver
Ratchet
10 mm Socket
19 mm Open end wrench
19 mm Ratchet wrench
5 mm Hex wrench
Torque wrench
Masking tape
Tape
Ruler
Drill
3 mm and 9 mm Drill bits
Eye protection (face shield, safety goggles, etc.)
File

The following tools are available through the Honda Tool and Equipment Program. On the iN, click on: Service > Service Bay > Tool and Equipment Program, then enter the number under "Search." Or, call 888-424-6857.

- Trim Tool Set (T/N SOJATP2014)
- Plastic Trim Tool (T/N SILTRIMTL10)
- 6 mm Rivet Nut Tool (T/N 07AAE-STX-A100)

Illustration of the Skid Plate on the Vehicle

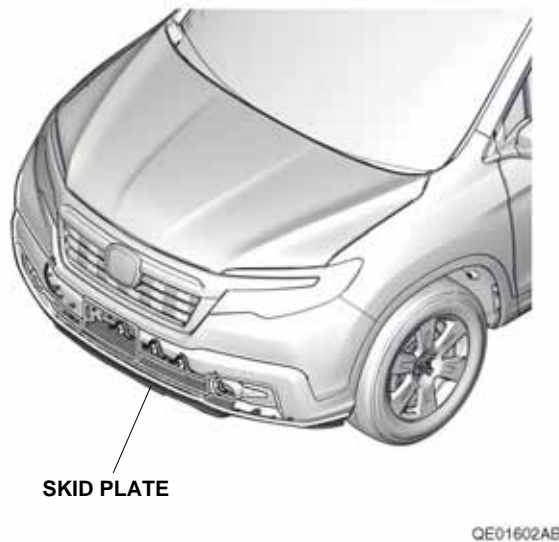

INSTALLATION

Customer Information: The information in this installation instruction is intended for use only by skilled technicians who have the proper tools, equipment, and training to correctly and safely add equipment to your vehicle. These procedures should not be attempted by "do-it-yourselfers."

1. Remove the four washer-bolts and seven clips.

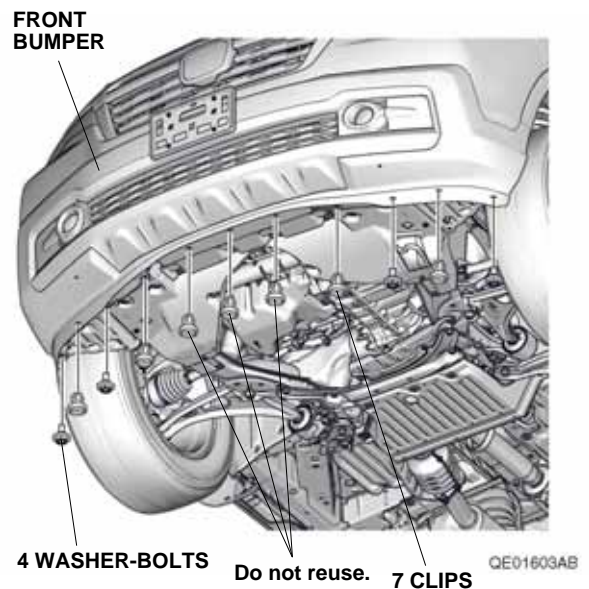

2. Remove the air dam.

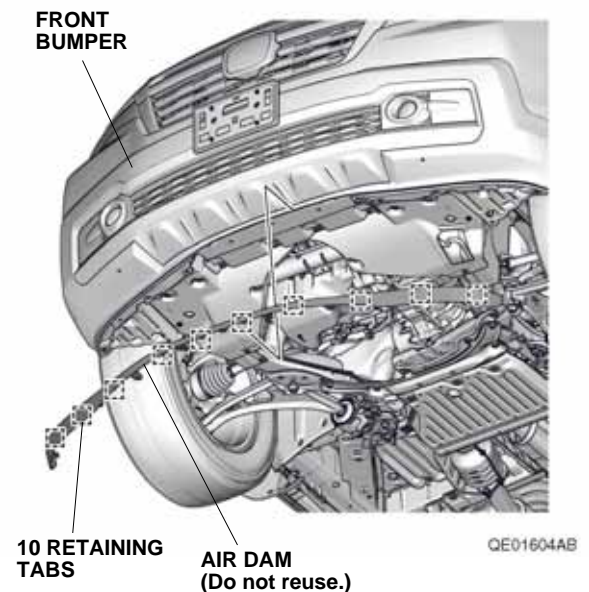

3. Install the two clips removed in step 1 as shown.

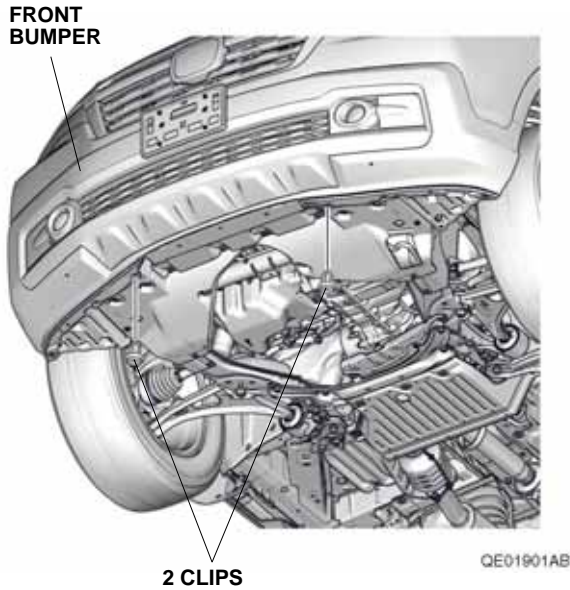

4. Install the left air dam with the two retaining tabs, two washer-bolts, and one clip removed in step 1. Install the right air dam the same way.

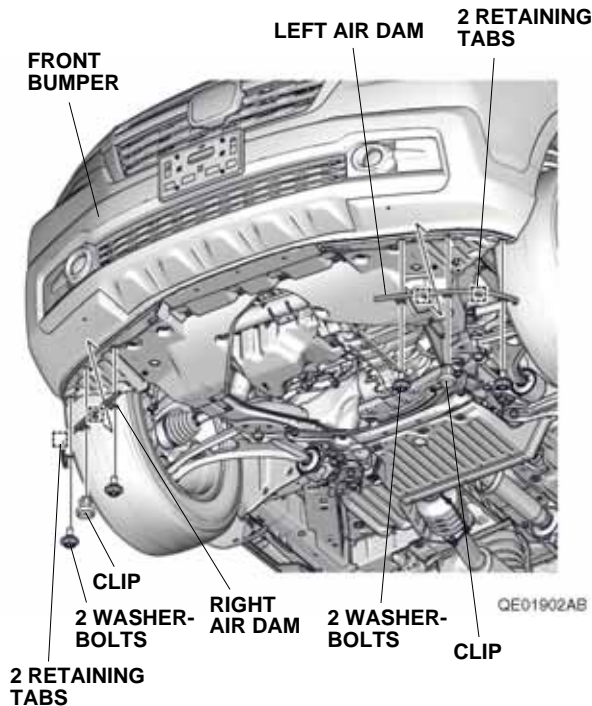

5. Line up the skid plate base with the humps on the front bumper. Temporarily attach the skid plate base to the front bumper with masking tape. Make sure there is no gap between the skid plate base and the front bumper.

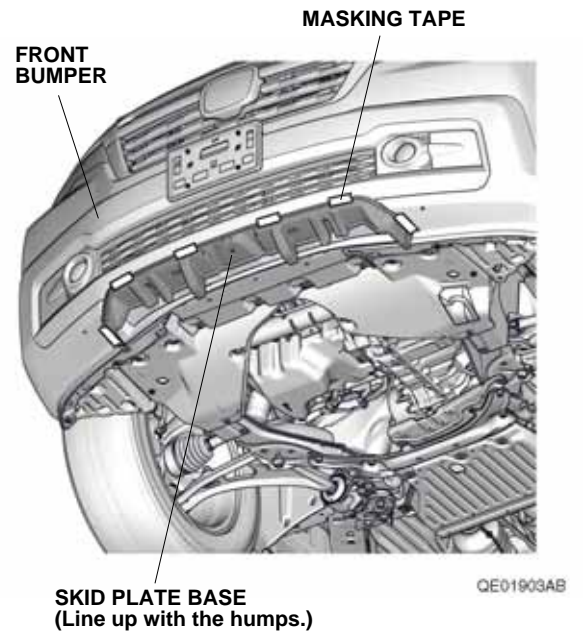

6. Locate the two dimples on the skid plate base. While wearing eye protection, drill the inside dimples on the skid plate base with a 3 mm drill bit. Make sure to drill through the skid plate base and front bumper. Remove any burrs.

NOTE: Wrap tape around a 3 mm drill bit 10 mm (0.39 in.) from the tip, or use a drill stop. Make sure to drill perpendicular to the skid plate base.

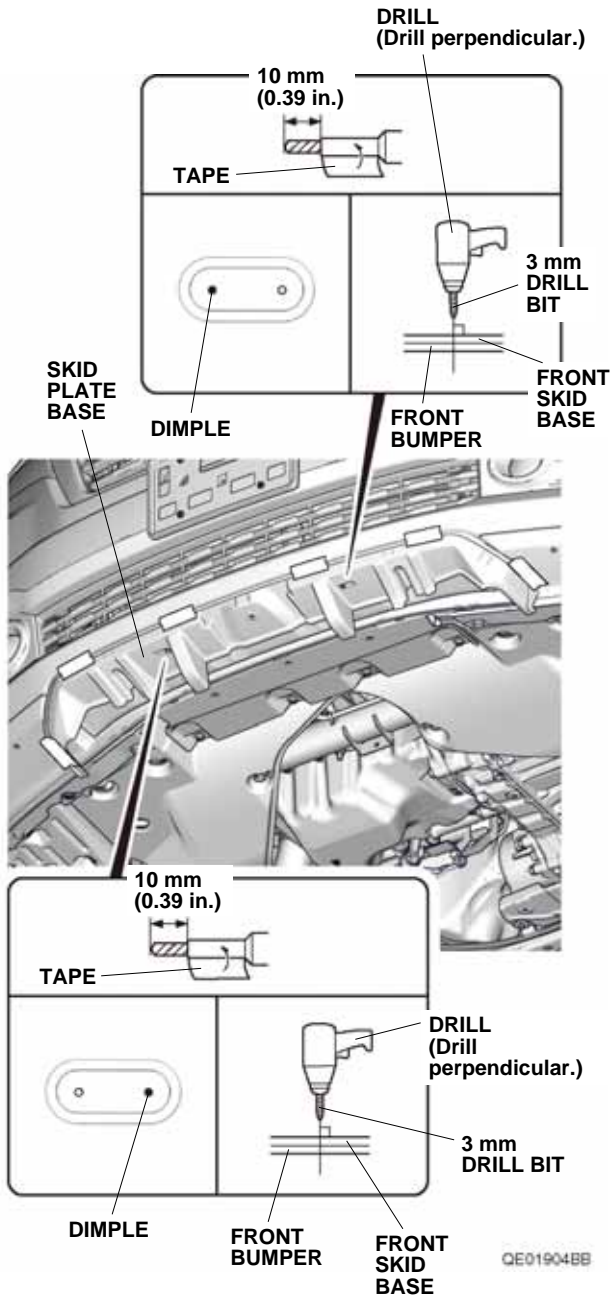

7. While holding the skid plate base against the front bumper, secure the skid plate base to the front bumper with the two self-tapping screws. Remove the masking tape attached in step 5.

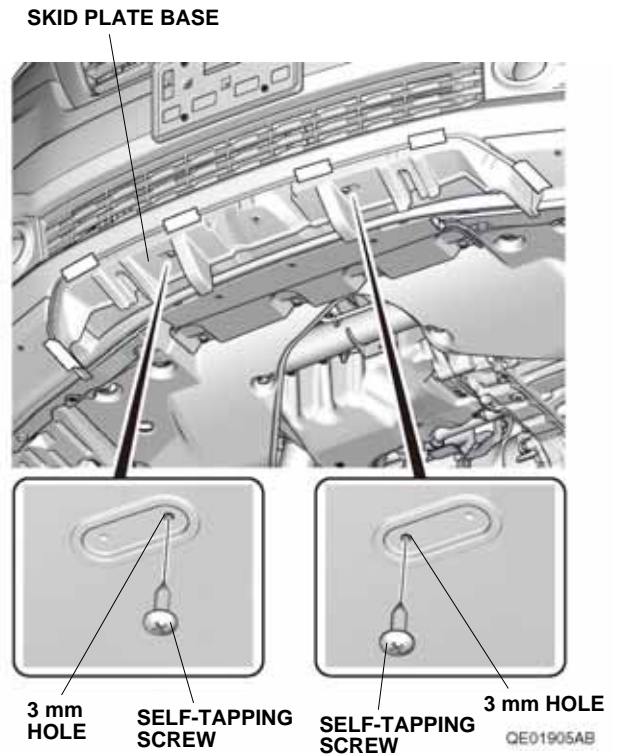

8. Make sure there are no gaps between the outside edge of the skid plate base and the front bumper. If a gap is found on the outside edge of the skid plate base, remove the self-tapping screws and realign the skid plate base. Repeat steps 5 through 7 to drill in the two alternate locations, then install the self-tapping screws in the alternate locations.

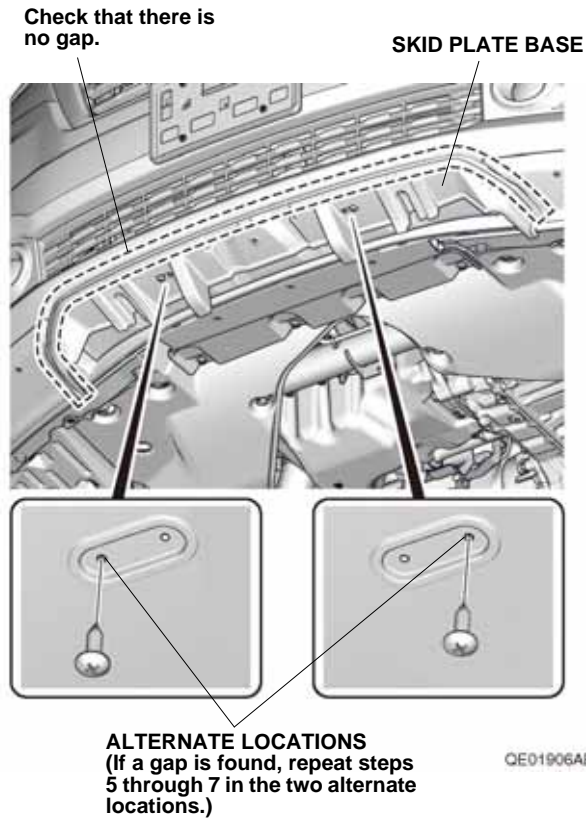

9. While wearing eye protection, drill the front bumper through each 9 mm hole in the skid plate base with a 9 mm drill bit. Remove any burrs.
NOTE: Wrap tape around a 9 mm drill bit 10 mm (0.39 in.) from the tip, or use a drill stop. Make sure to drill perpendicular to the front bumper.

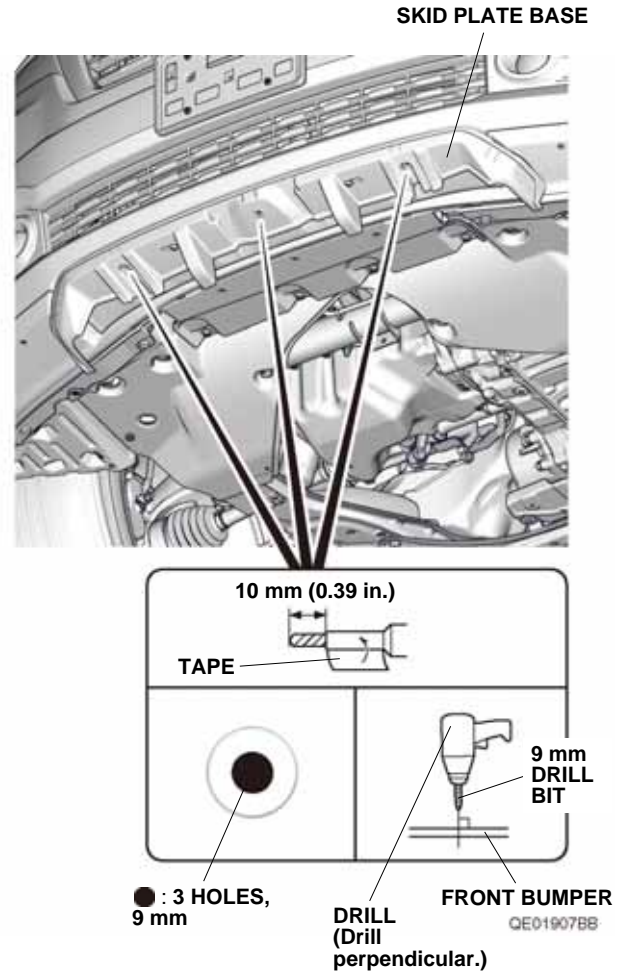

- Turn the nut on the rivet nut tool counterclockwise until the stud is fully extended.

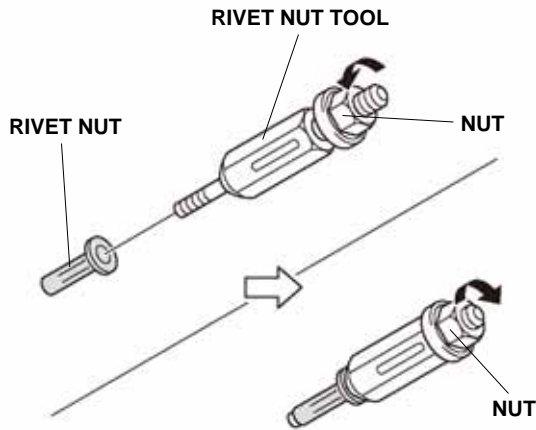

QE01908AB

- Engage all of the threads on the stud into the rivet nut.
- Turn the nut on the rivet nut tool clockwise until it becomes tight.
- Insert the rivet nut into the 9 mm hole. Place the 19 mm open end wrench on the rivet nut tool body and hold stationary using a 19 mm ratchet wrench on the nut.

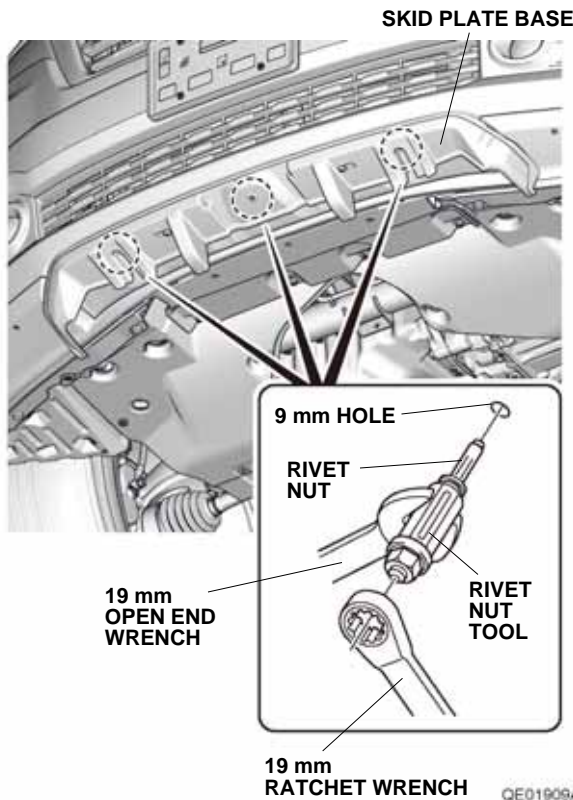

QE01909AB

- Turn the 19 mm ratchet wrench clockwise while holding the rivet nut tool perpendicular to the skid plate base. Turn the nut until firm resistance is felt. Several turns are required.

NOTE: Be careful not to overtighten the nut.

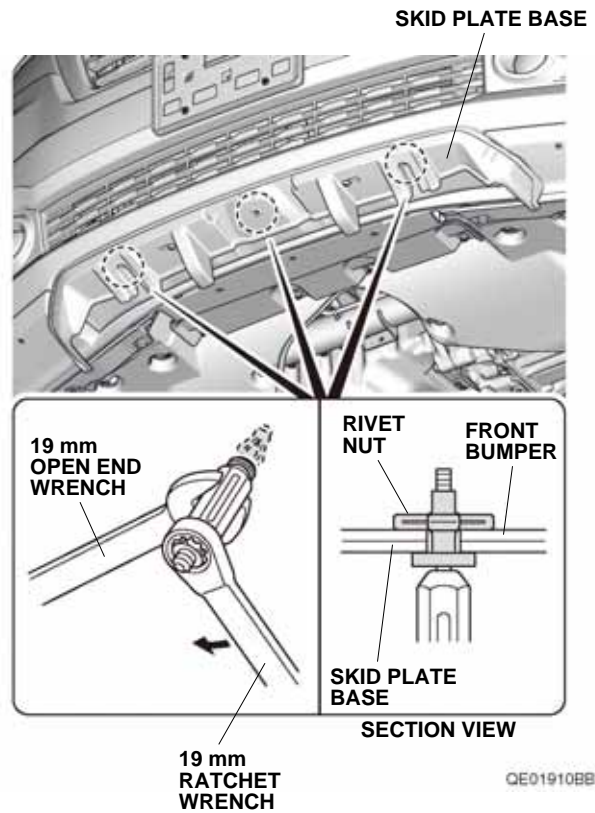

QE01910BB

15. Remove the rivet nut tool from the rivet nut by turning the rivet nut tool body counterclockwise.

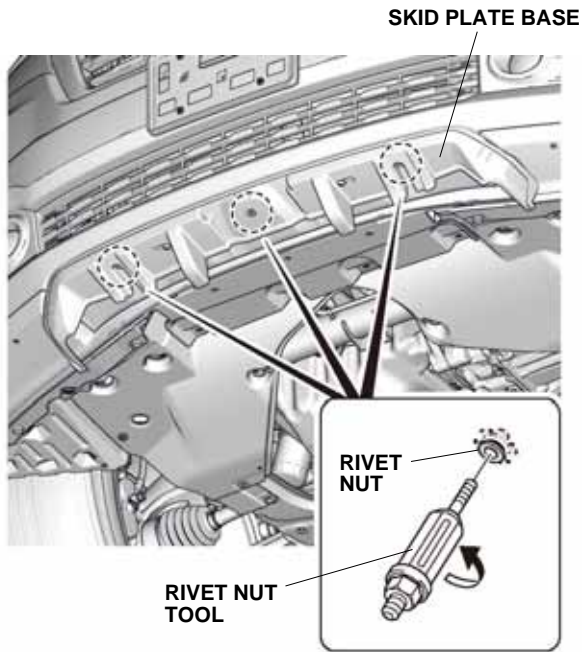

16. Repeat steps 10 through 15 to install the remaining rivet nuts.

17. Remove the four bolts from the front bumper.

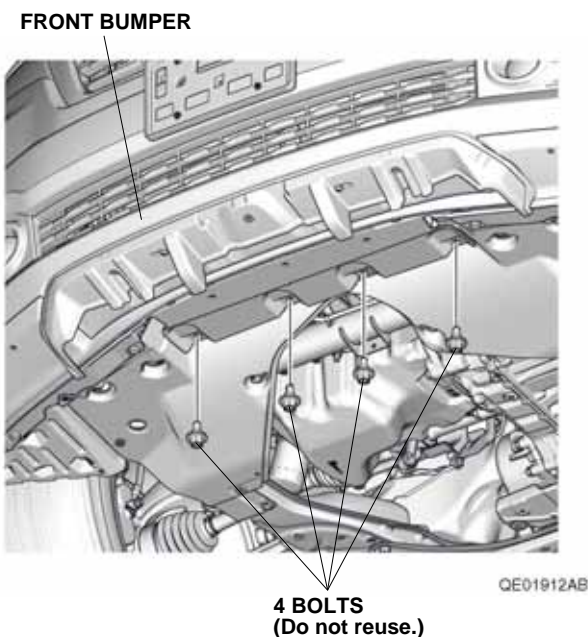

18. Loosely install the skid plate to the front bumper with the four shoulder bolts.

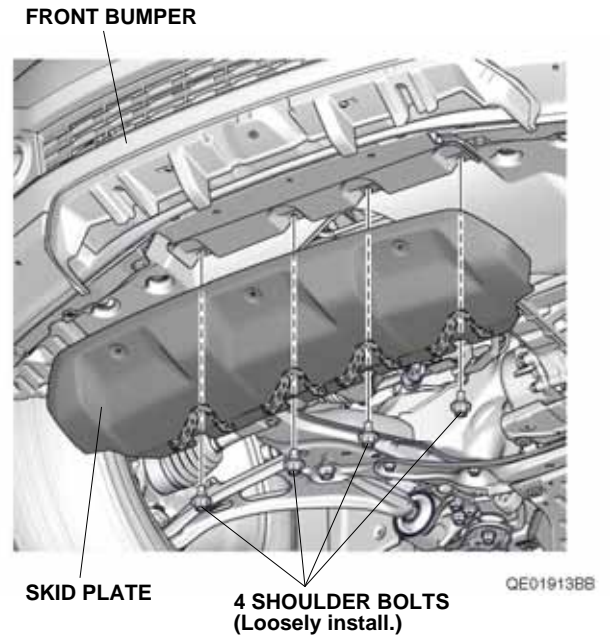

19. Loosely secure the skid plate to the front bumper with one 6 x 24 mm bolt, two 6 x 40 mm bolts, and three washers.

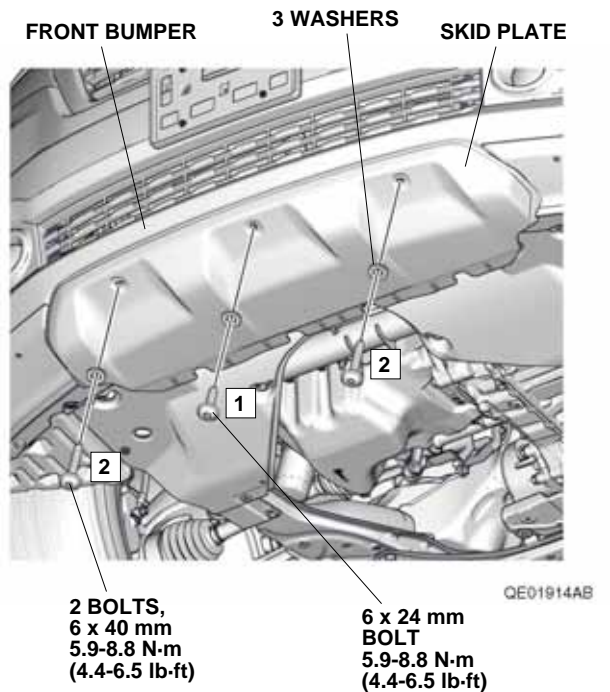

20. Tighten the 6 x 24 mm bolt first, then tighten the two 6 x 40 mm bolts on each side. Tighten while applying pressure so that there is no gap between the skid plate and the skid plate base. Torque the bolts to 5.9-8.8 N·m (4.4-6.5 lb·ft).

21. Tighten the four shoulder bolts loosely installed in step 18. Tighten the two inside shoulder bolts first, then tighten the two shoulder bolts on each side. Torque the shoulder bolts to 6.9-11.8 N·m (5.1-9 lb·ft).

