



INSTALLATION INSTRUCTIONS

Accessory
**REAR LOWER TRIM,
 TRAILER HITCH,
 AND TRAILER HARNESS**

Application
**2024 PROLOGUE
 MODEL SERIES**

Publications No.
VERSION 1
 Issue Date
MAR 2024

GENERAL VIEW

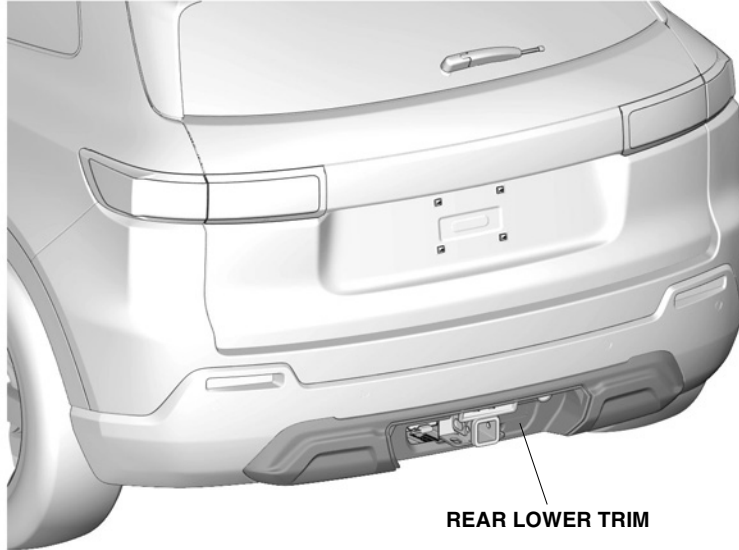

QN00201AT

FOR YOUR SAFETY (Read carefully.)

Warning Symbols

Safety: Your safety, and the safety of others, is important. To help you make informed decisions about service procedures, we have provided safety messages where appropriate. Of course, it is not practical or possible to warn you about all the hazards associated with servicing a vehicle - you must use your own good judgment.

You will find important safety messages preceded by one of the following symbols:

*All symbols are not used in all installation instructions.

⚠ DANGER

You will be killed or seriously hurt if you do not follow the instructions.

⚠ WARNING

You can be killed or seriously hurt if you do not follow the instructions.

⚠ CAUTION

You can be hurt if you do not follow the instructions.

NOTICE

Gives advice to prevent damage to the product, vehicle, the environment or other property.

NOTE

Gives helpful information or instructions to be followed when installing this product.



Indicates a prohibited action.

Procedure and Location Icons

These icons indicate the work location and the worker's point of view.

*All icons are not used in all installation instructions.

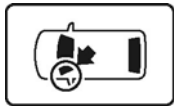

The location on the vehicle.

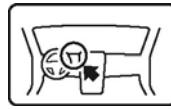

The location in the vehicle.
(Instrument panel.)



Wear eye protection.



Wear heavy gloves.



Use an assistant.



Place the part on a blanket.



Work perpendicular.



Remove any burrs.



Use touch-up paint and allow to dry.



Tighten to the specified torque.



Apply firm pressure while rolling, especially at the ends, to set the adhesive.



Press firmly.



Clean with isopropyl alcohol.



Return the original part to the customer.
(Do not reuse.)

Wire Harness Routing Precaution

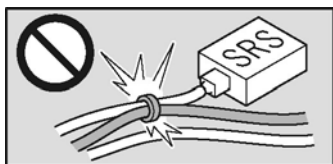

Do not secure the accessory harness to the SRS harness.
(except for instruction cases.)

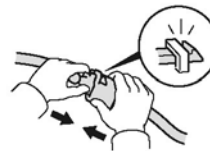

Push the connectors and terminals together until they lock.

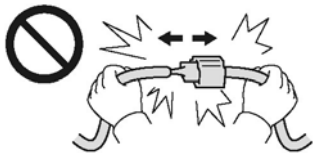

Do not pull the harness to unplug the connectors.

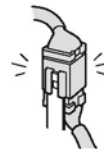

Install removed connectors in their original location.

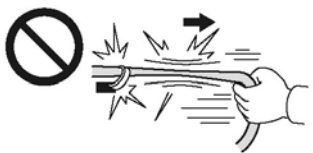

Do not pull the harness.



Secure the accessory harness as shown.



Do not pinch the harness.

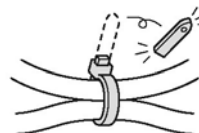

Cut off the excess wire tie.

Safety: General

- Observe all safety notes and precautions described in the service information, in addition to those described in this Installation Instruction. Be extremely careful for your safety and the safety of others.
- Be careful not to damage the vehicle or the parts.
- Be extremely careful when handling retaining tabs and clips.
- Note the locations of the parts before removing them so they can be properly installed in their original positions.
- The illustrations may differ slightly from the actual accessory.

Safety: Electric Parts



Always disconnect the negative cable from the battery before beginning work.

Safety: Accessory



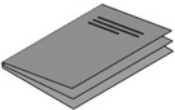

Always use the parts and tools specified in the installation instructions.

PARTS LIST

Rear Lower Trim Kit (P/N 08F24-PS2-100A)

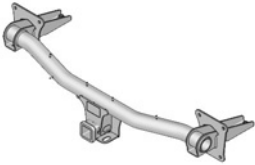
Rear lower trim	Wire tie	Wire ties with clip (3) (Some may not be used)	Accessory User's Information Manual (May not be used)
			

Trailer Hitch Kit (P/N 84933501)

Trailer hitch	Harness and harness mounting hardware	Reinforcement plates (2)	M12 x 1.75 Bolts (4)
			

REQUIRED TOOLS AND SUPPLIES

- Phillips screwdriver
- Utility knife
- File
- T15 and T20 TORX bits
- Ruler
- Torque wrench
- 10 mm Open end wrench
- 7 mm and 10 mm Sockets
- Diagonal cutters
- Needle nose pliers
- Flat bladed tool
- Kent[®] High Tech Seam Sealer P10200 or equivalent
- Ratchet
- Masking tape
- Blanket
- 10 mm Hex wrench
- Wire brush

The following tools are available through the Honda Tool and Equipment Program:

- Trim Tool Set (T/N SOJATP2014)
- Plastic Trim Tool (T/N SILTRIMTL10)

INSTALLATION

1. Disconnect the 12V battery. Refer to the service information.
2. Remove the left cover.

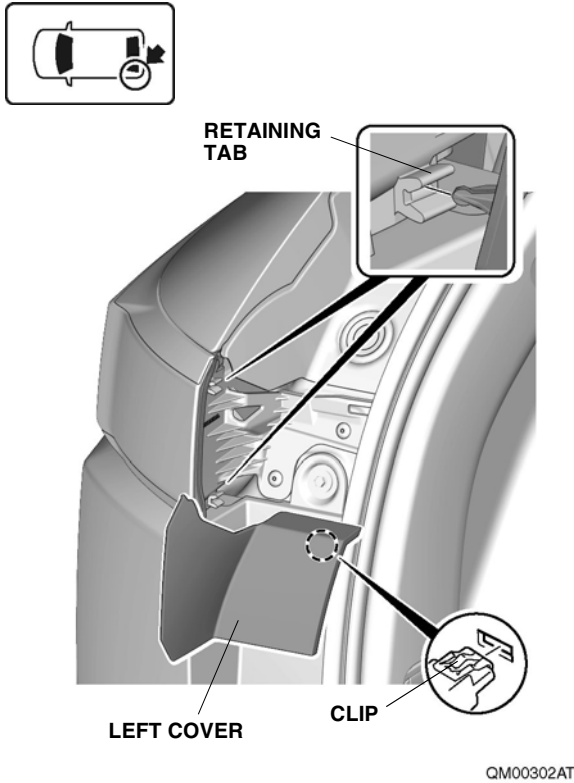

3. Repeat step 2 on the other side.

4. Attach masking tape to protect the vehicle.

NOTE
Do not remove the masking tape until after the parts are installed.

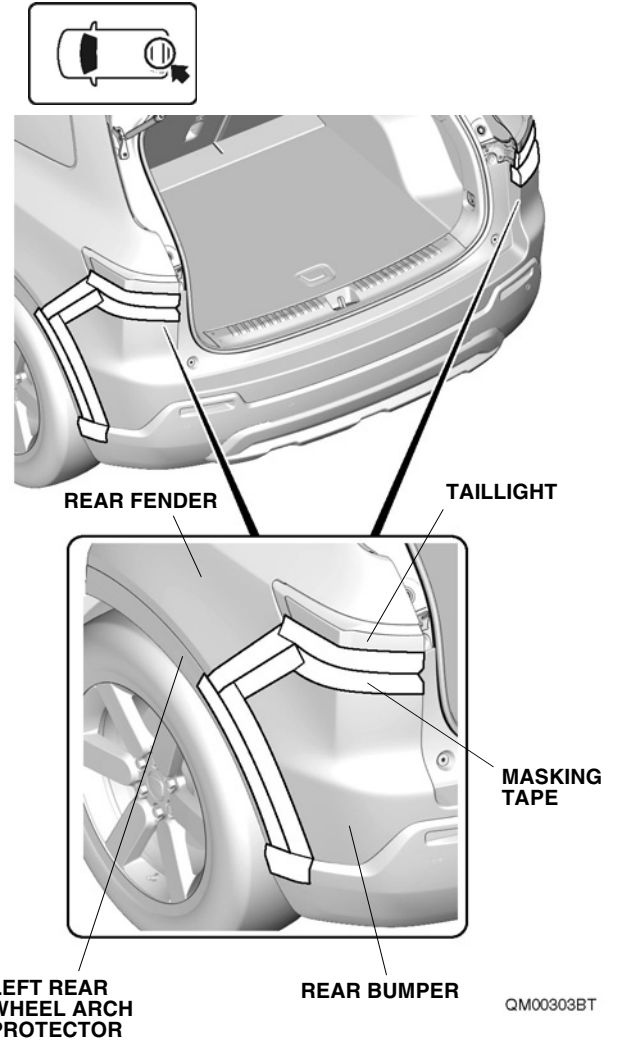

5. Remove the self-tapping screws.

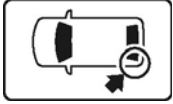

7 SELF-TAPPING
SCREWS

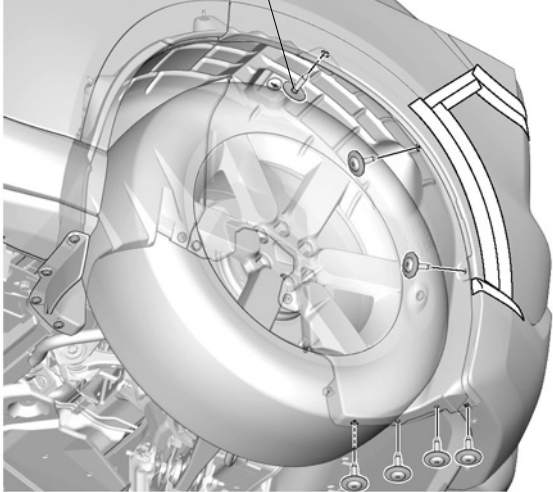

QM00309CT

6. Release the left rear wheel arch protector.

NOTICE

- Be careful not to damage the clips.
- If you cannot release a clip using the 7 mm socket, use a trim tool.

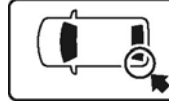

3 CLIPS
(Use a 7 mm socket
to release the clips.)

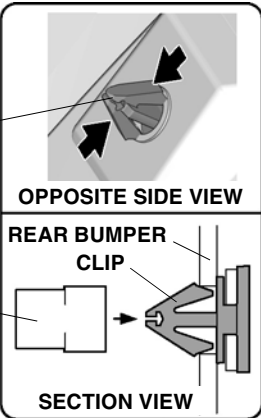

OPPOSITE SIDE VIEW

REAR BUMPER
CLIP

7 mm
SOCKET

SECTION VIEW

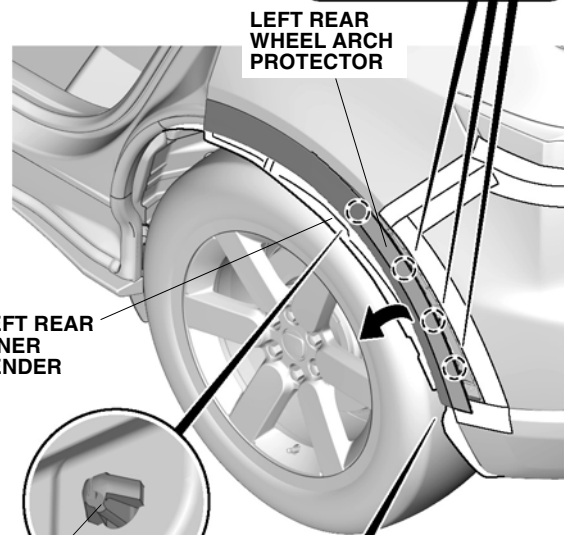

LEFT REAR
WHEEL ARCH
PROTECTOR

LEFT REAR
INNER
FENDER

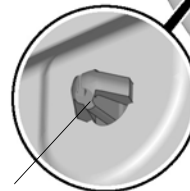

CLIP

OPPOSITE
SIDE VIEW

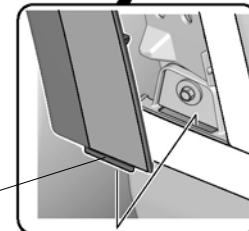

RETAINING
TAB

QM00305ET

7. Repeat the same procedures on the other side.

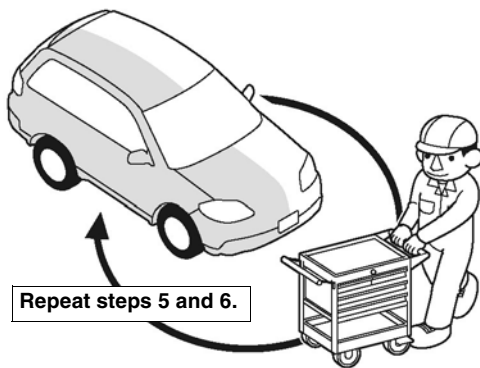

Q9D1014AM

8. Remove the bolts and self-tapping screws.

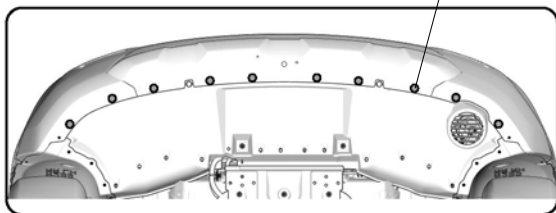
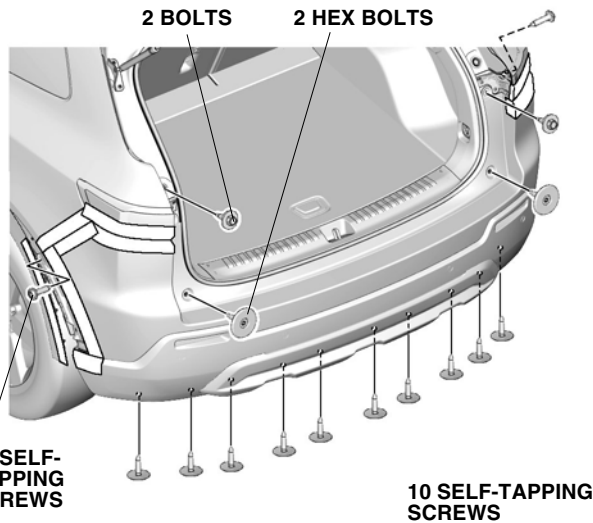
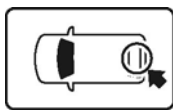

QM00306CT

9. Release the retaining tabs.

NOTE

- Release the retaining tabs starting from outside working in.
- Make sure to release the retaining tabs in the correct orientation.

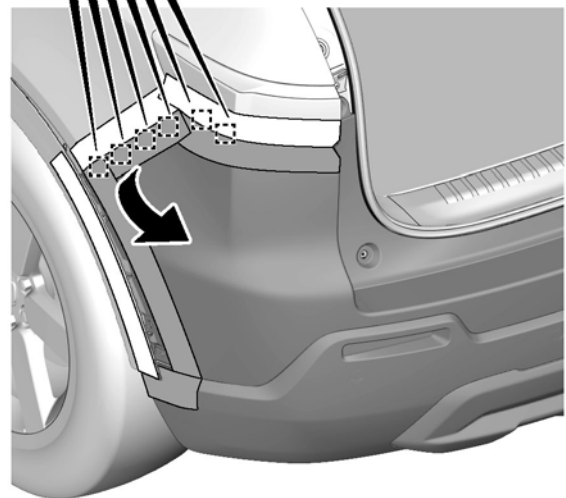
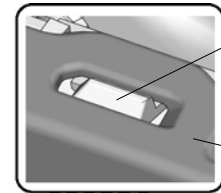
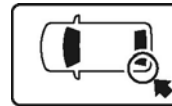

QM00307CT

10. Repeat step 9 on the other side.

11. Remove the rear bumper.

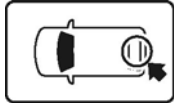

VEHICLE CONNECTORS

3 RETAINING TABS

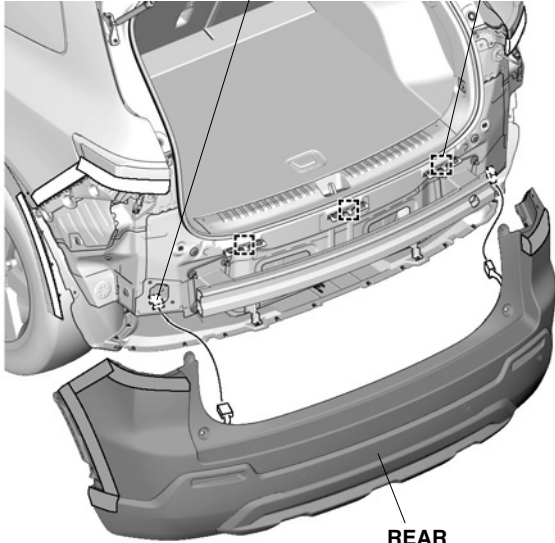

REAR BUMPER

QM00308CT

12. Remove the nuts securing the rear fascia impact bar.

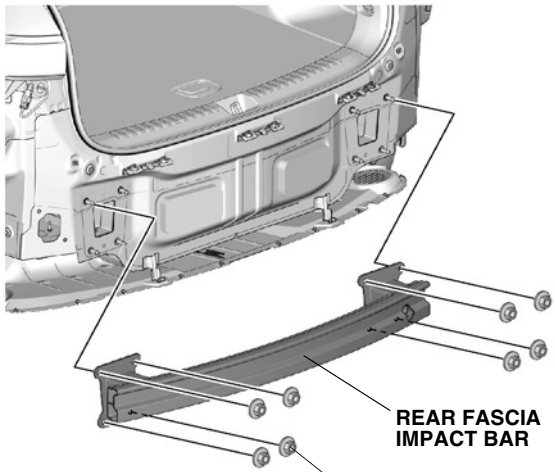

REAR FASCIA IMPACT BAR

8 NUTS
(Retain)

QN00205AT

13. Retain the nuts.

14. Remove the rear fascia impact bar from vehicle.

15. Using a flat bladed tool, remove the body sealant in the area shown to allow installation of the hitch reinforcement plates. Use a wire brush to remove any debris. The hitch mating surface must be clean of any sealant or foreign material. The body sealant should be removed approximately 5 mm beyond the ends of the reinforcement plates.

NOTE

Left side shown, right side similar.

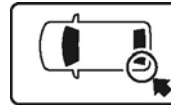

BODY SEALANT

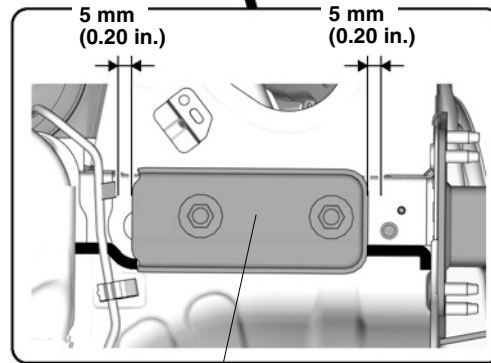
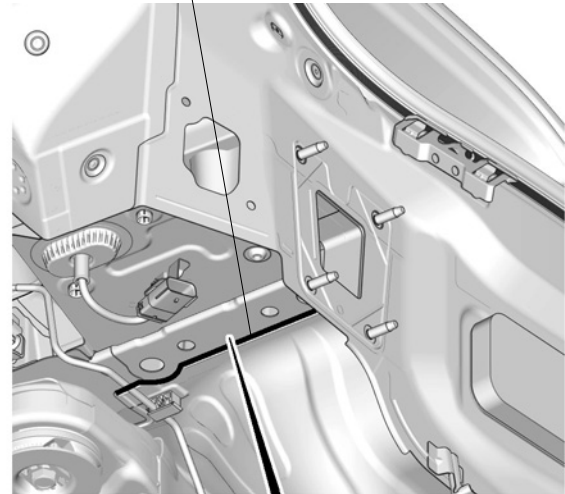

REINFORCEMENT PLATE

QN00206AT

16. With the aid of an assistant, insert the trailer hitch into the body rails. Secure the trailer hitch with the retained impact bar nuts. Tighten the nuts using a cross pattern from left side to right side to ensure an even load distribution.

NOTICE

Use the correct fastener in the correct location. Replacement fasteners must be the correct part number for that application. Fasteners requiring replacement or fasteners requiring the use of thread locking compound or sealant are identified in the service procedure. Do not use paints, lubricants, or corrosion inhibitors on fasteners or fastener joint surfaces unless specified. These coatings affect fastener tightening sequence and specifications. Follow this guidance when installing fasteners in order to avoid damage to parts and systems.

NOTE

- If the acoustic insulation interferes with plate installation or removal of body sealant, the insulation can be moved out of the way by removing the retention clip. The clip for the insulation must be unscrewed so the insulation can be removed. Do not pull these clips or they will be damaged. Reinstall the clip and position the insulation over the plate after the plate has been installed and sealant applied.
- If equipped with a Vehicle External Speaker and the bracket impedes the removal of the body sealant and installation of the reinforcement plate, the speaker screw and bracket can be temporarily removed. Reinstall bracket and speaker after installation of plate and application of body sealant.

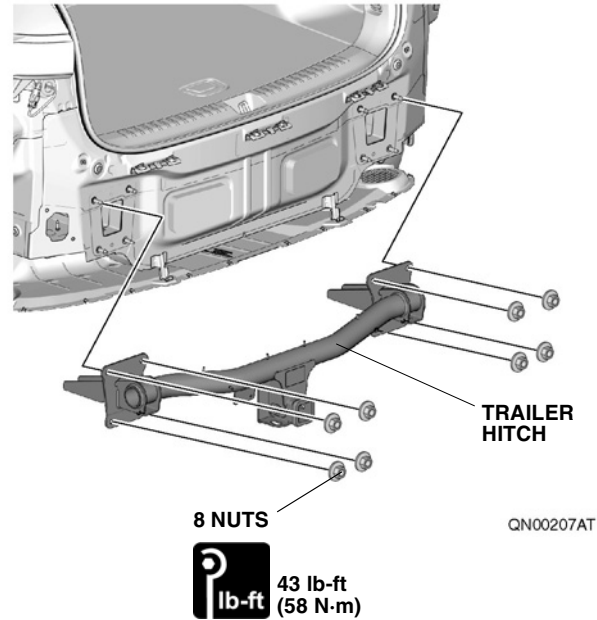
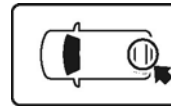

17. Install the reinforcement plates to the frame under side and secure the trailer hitch with the supplied M12 x 1.75 bolts.

⚠ WARNING

Failure to correctly install reinforcement plates could lead to trailer hitch detachment and loss of installed or towed items, resulting in a crash causing serious injury or death. Always observe correct orientation of plates, with plates installed dish side down with step in plate to match step in body rail. Incorrect installation of plates may result in damage to frame rail, structural integrity of hitch platform and loss of trailer hitch attachment to vehicle.

NOTE

Left side shown, right side similar.

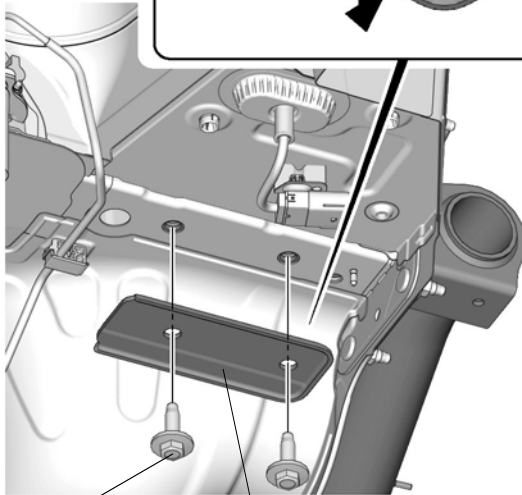
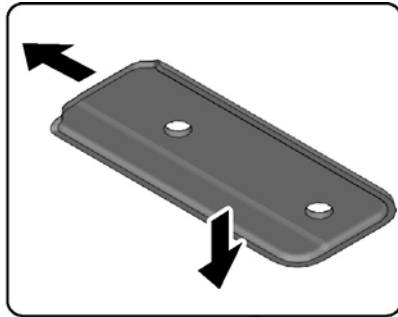
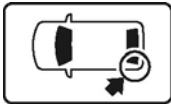

2 BOLTS



74 lb-ft
(100 N·m)

REINFORCEMENT
PLATE

QN00208BT

18. Re-apply Kent® High Tech Seam Sealer P10200 or equivalent to the area indicated.

NOTE

Left side shown, right side similar.

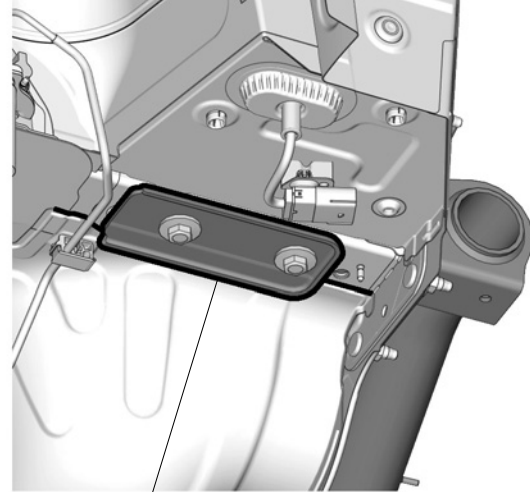

SEALER

QN00209AT

19. Attach the wiring harness connector to the harness bracket.

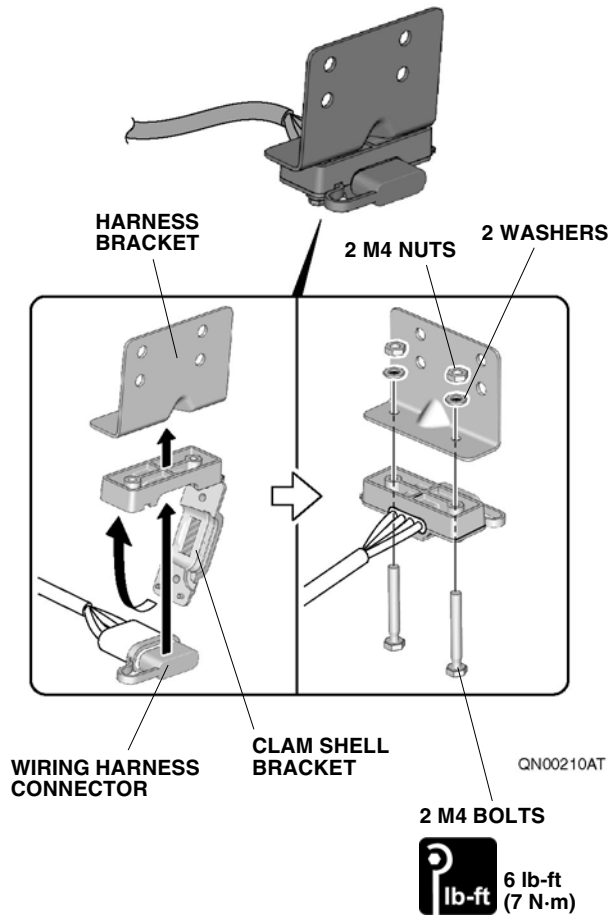

20. Carefully center the wiring harness connector in the clam shell bracket.
21. Attach the clam shell bracket and harness connector assembly to the harness bracket with the supplied M4 bolts, washers and M4 nuts.

22. Attach the harness bracket assembly to the trailer hitch with the supplied M6 x 1 bolts.

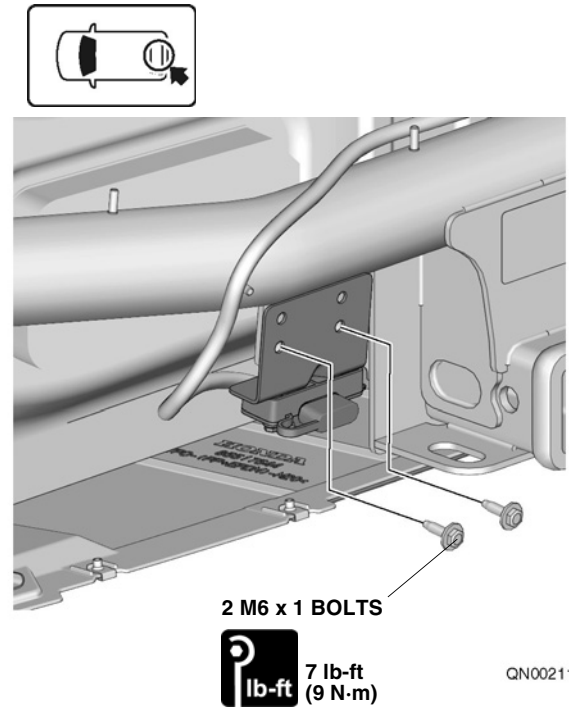

23. Push the wire ties with clips onto the studs on the trailer hitch and secure the wiring harness with the wire tie straps.

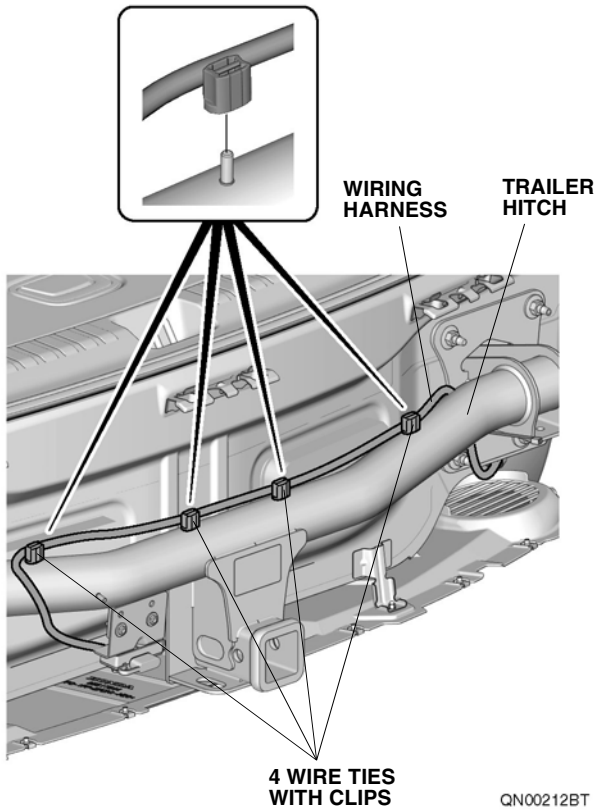

24. For vehicles with the Vehicle Exterior Sound (VES) speaker, remove the speaker to access the body harness connector.

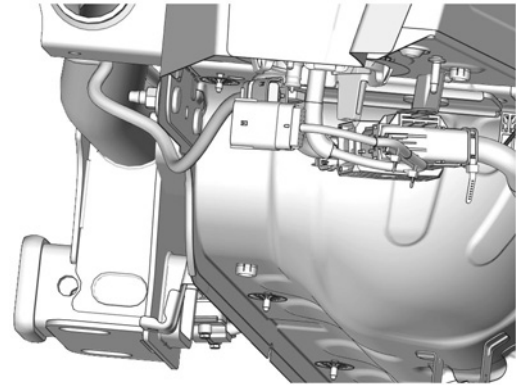
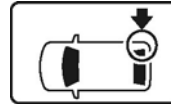

25. Remove the vehicle harness connector cap and connect the trailer hitch harness connector to the vehicle harness connector. Be sure to engage the RED CPA (Connector Position Assurance) after making the connection.

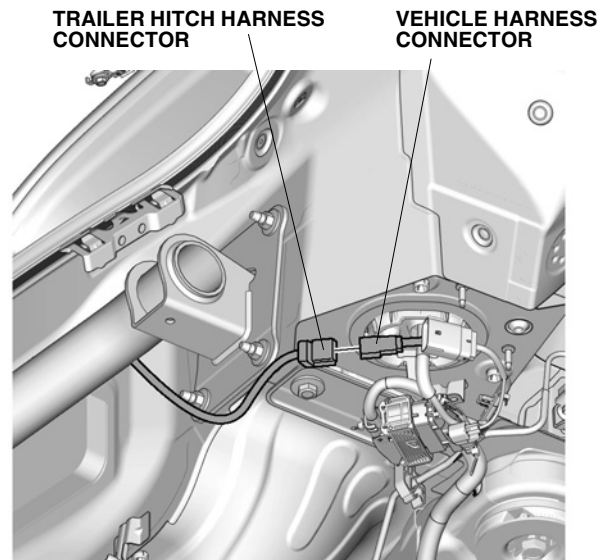
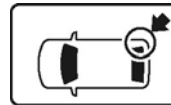

Check the Operation of the Trailer Harness

26. Refer to the "TRAILER HARNESS TESTER", and perform the "Trailer Harness Circuit Check".

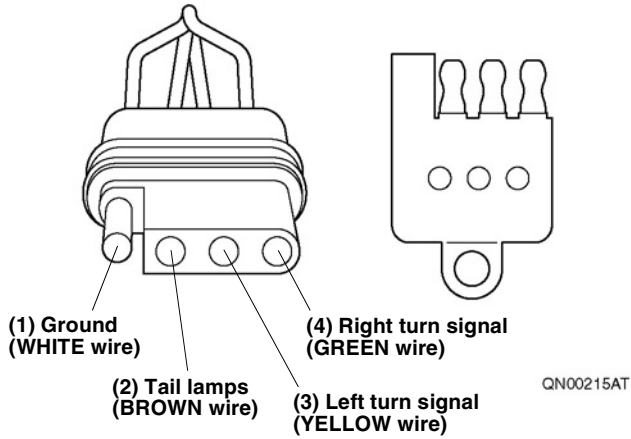

27. Once the harness connection is made and testing complete, loop extra wire length and install the wire tie securing the harness to the trailer hitch.

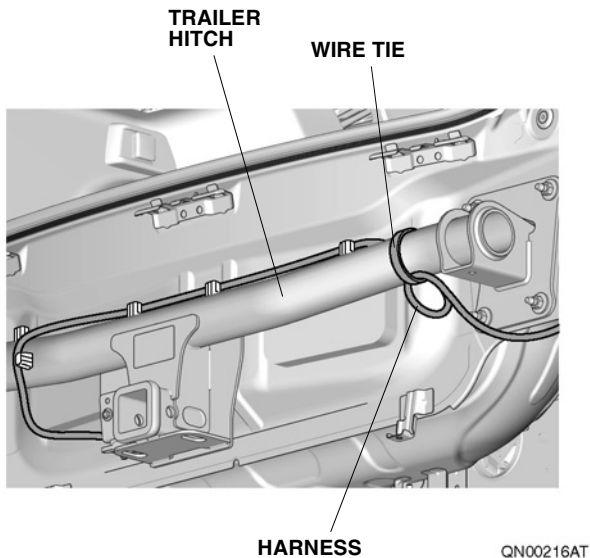
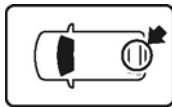

28. Remove the self-tapping screws and vehicle harness (with hands-free access).

NOTE

Be careful not to damage the vehicle harness.

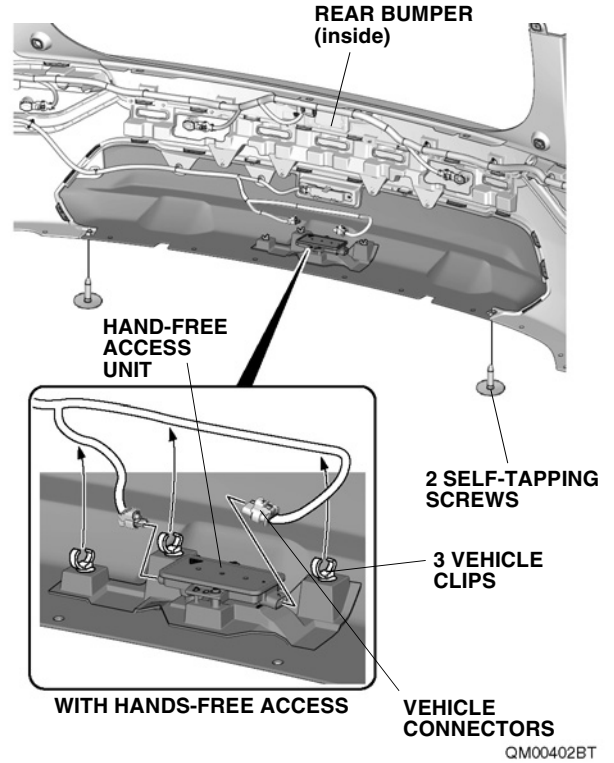

29. Remove the rear lower trim.

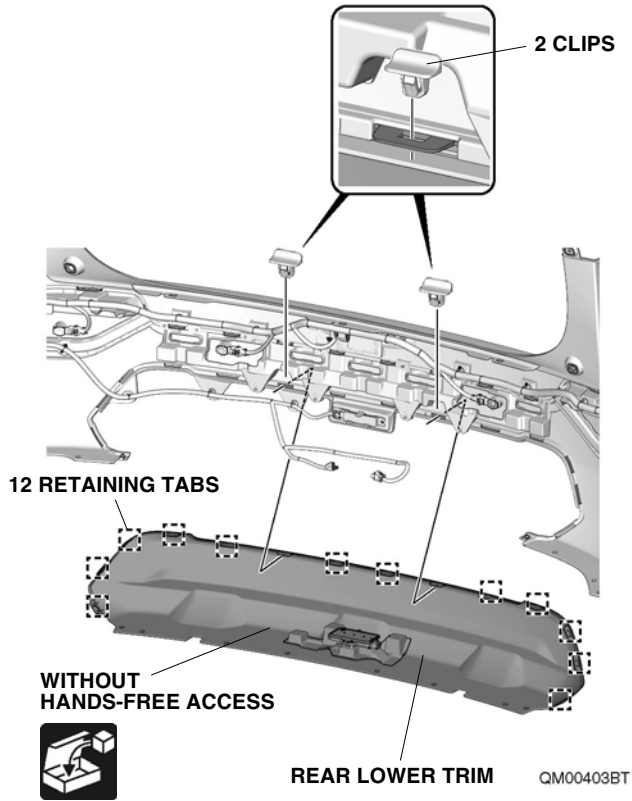

30. Remove the antenna.

NOTE

Be careful not to damage the vehicle harness.

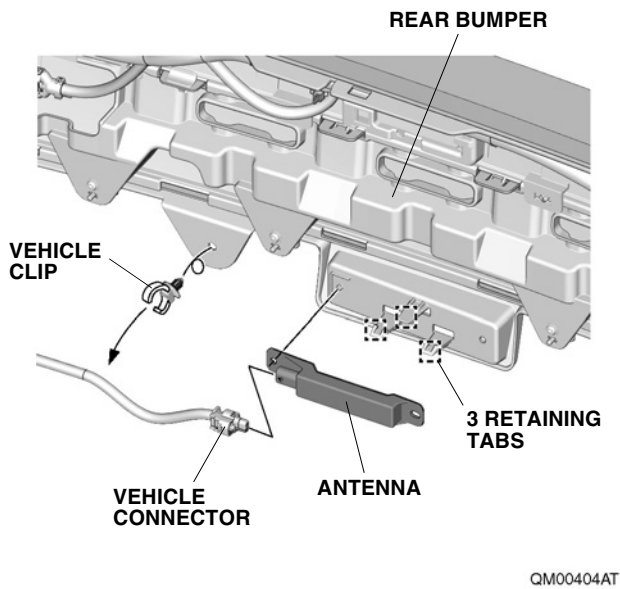

31. Choose one of these options.

• With hands-free access

Go to step 32

• Without hands-free access

Go to step 34

32. Remove the hands-free access unit.

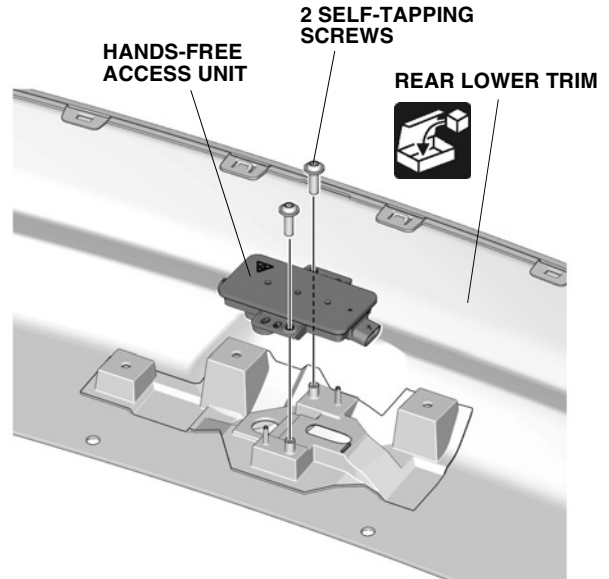

33. Install the hands-free access unit.

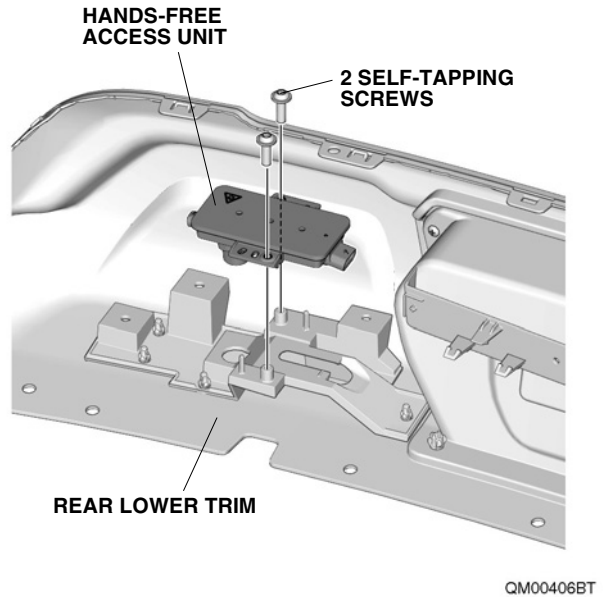

34. Install the antenna.

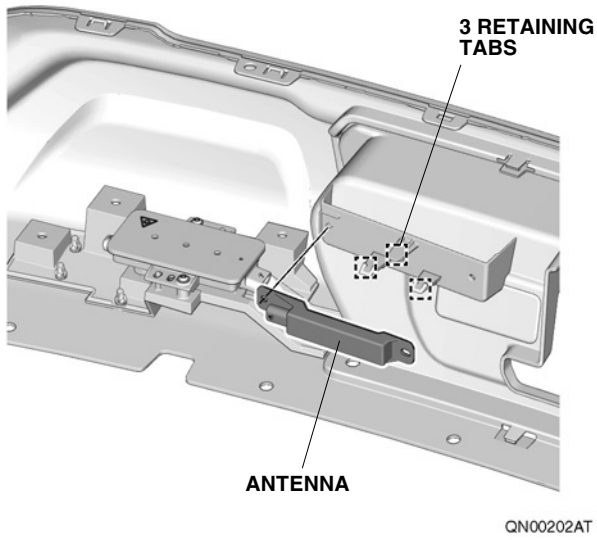

35. Cut the rear bumper.

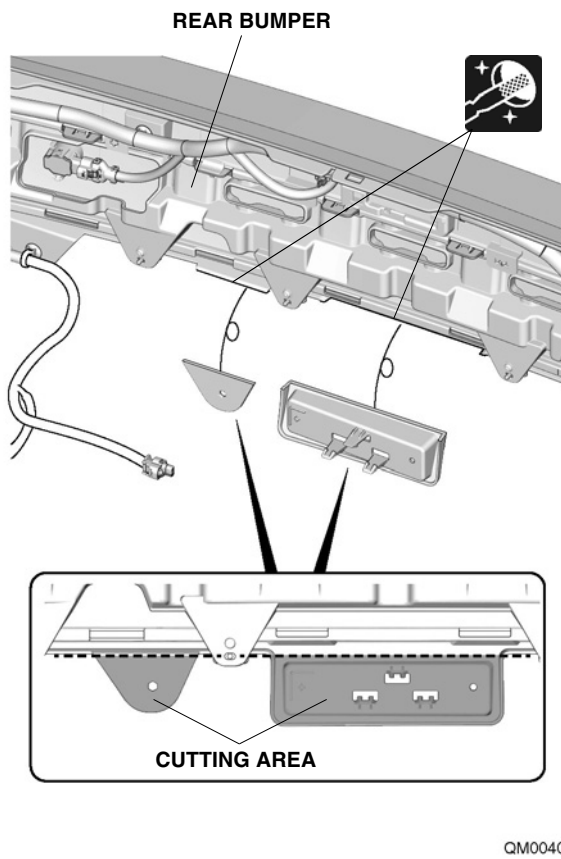

36. Install the rear lower trim.

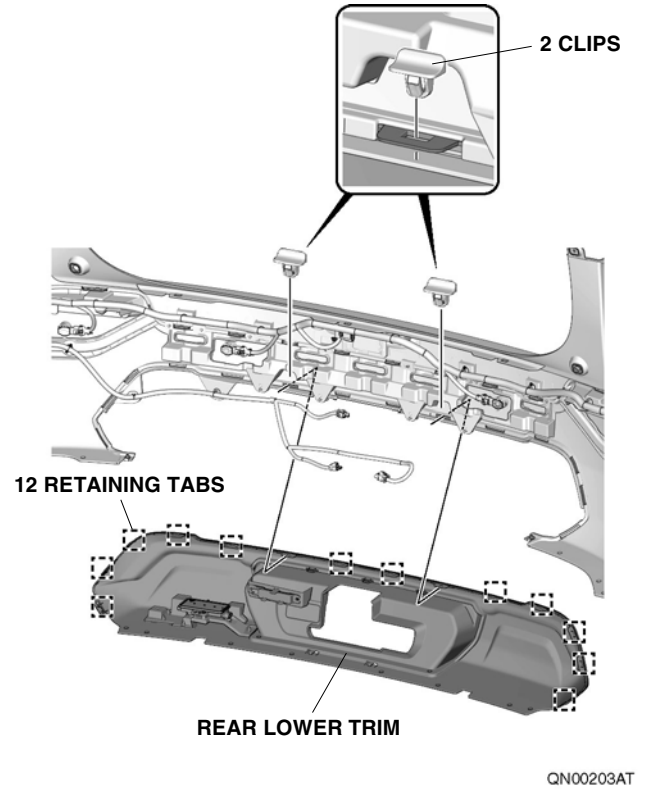

37. Secure the rear lower trim.

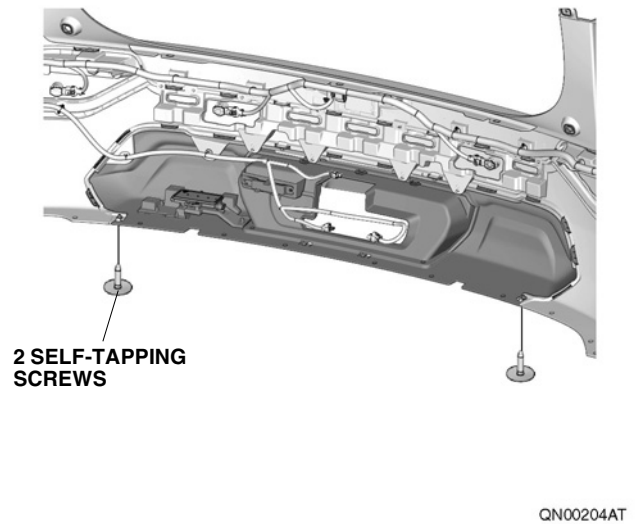

38. Choose one of these options.

- | | |
|-----------------------------|---------------|
| • With hands-free access | Go to step 39 |
| • Without hands-free access | Go to step 43 |

39. Plug the vehicle connectors.

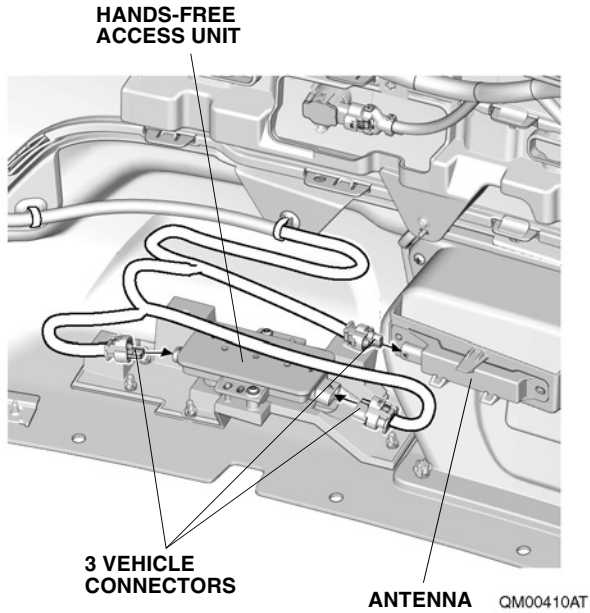

40. Secure the vehicle harness.

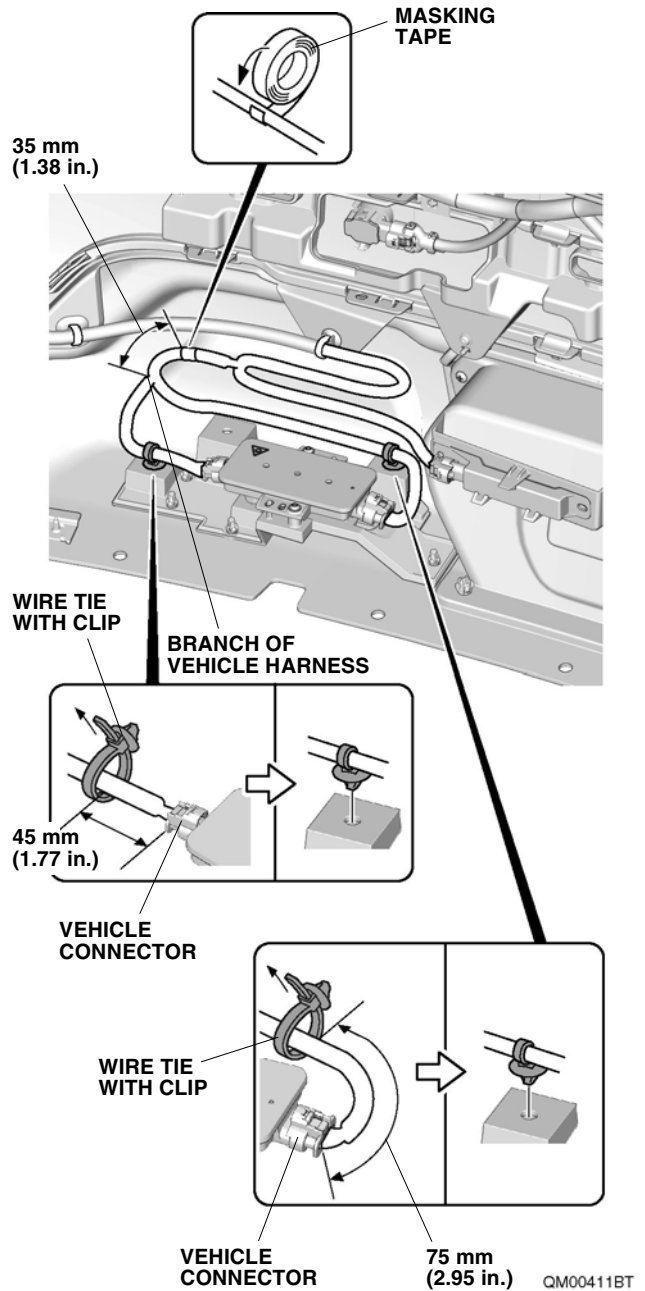

41. Mark the vehicle harness.

42. Secure the vehicle harness.

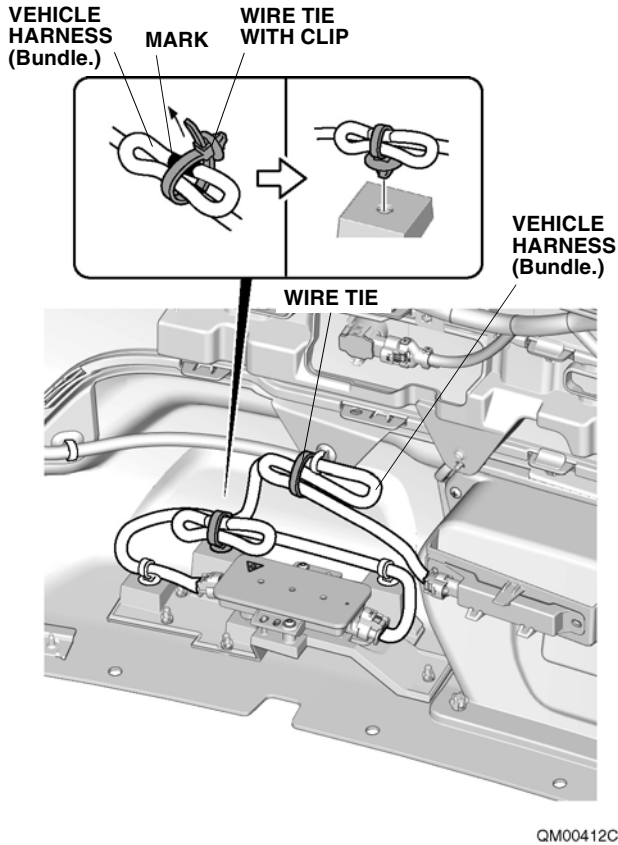

Go to step 45

43. Plug the vehicle connector.

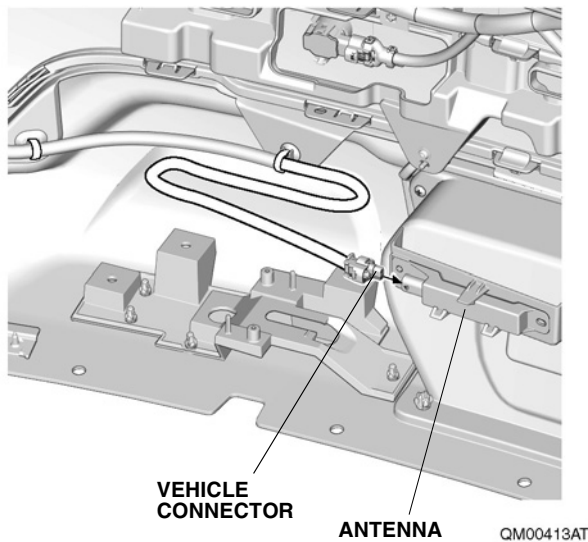

44. Secure the vehicle harness.

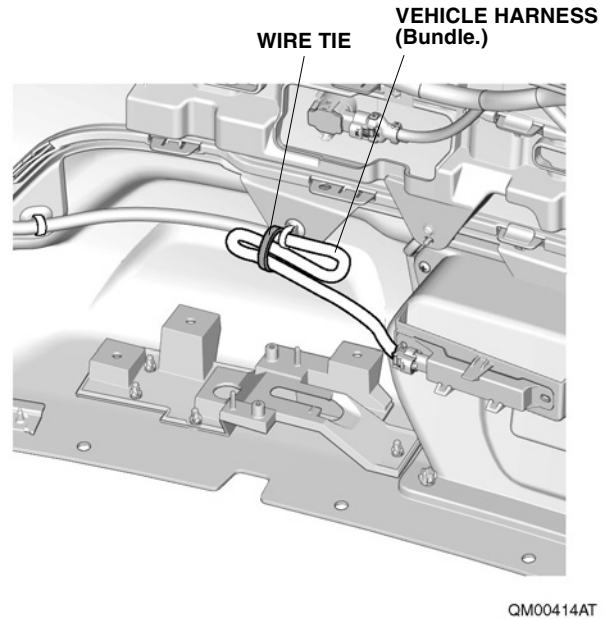

45. Check that all parts are installed and properly routed.

NOTE

- Check that all harnesses are not pulled or pinched.
- Make sure all clips and wire ties are securely installed.

46. Install all removed parts.
47. Connect the 12V battery. Refer to the service information.
48. Make sure all accessories and systems operate properly.
49. If necessary, restore the systems back to normal operation as described in the service information.
50. Press and hold the audio unit power button for 2 seconds to restore the audio and navi (if equipped) system functions.

51. Place retention collar around hitch receiver with orientation as shown. Firmly press cover onto receiver opening.

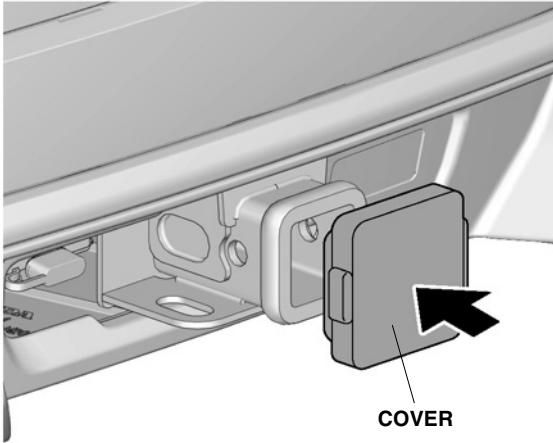
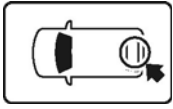

COVER

QN00217BT