

# Germain Honda of College Hills



## INSTALLATION INSTRUCTIONS

Accessory  
18" ALUMINUM WHEEL

Application  
2023 PILOT  
MODEL SERIES

Publications No.  
**VERSION 1**  
Issue Date  
**NOV 2022**

## GENERAL VIEW

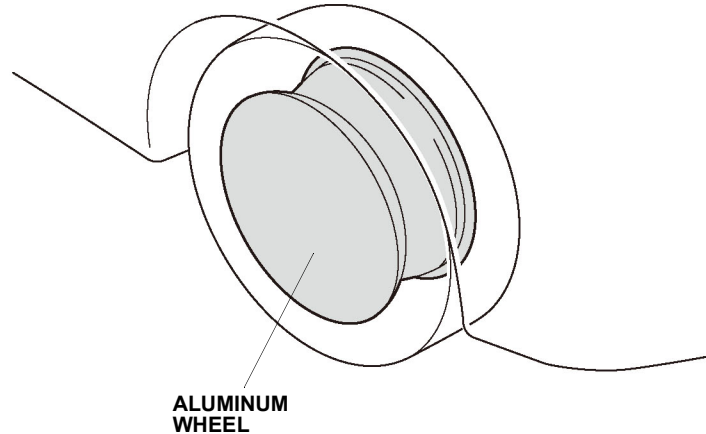

Q0N0101AJ

## FOR YOUR SAFETY (Read carefully.)

### Warning Symbols

**Safety:** Your safety, and the safety of others, is important. To help you make informed decisions about service procedures, we have provided safety messages where appropriate. Of course, it is not practical or possible to warn you about all the hazards associated with servicing a vehicle - you must use your own good judgment.

You will find important safety messages preceded by one of the following symbols:

\*All symbols are not used in all installation instructions.

 **DANGER**

You will be killed or seriously hurt if you do not follow the instructions.

 **WARNING**

You can be killed or seriously hurt if you do not follow the instructions.

 **CAUTION**

You can be hurt if you do not follow the instructions.

**NOTICE**

Gives advice to prevent damage to the product, vehicle, the environment or other property.

**NOTE**

Gives helpful information or instructions to be followed when installing this product.



Indicates a prohibited action.

# Germain Honda of College Hills

## Procedure and Location Icons

These icons indicate the work location and the worker's point of view.

\*All icons are not used in all installation instructions.

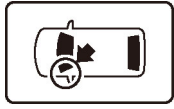

The location on the vehicle.

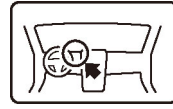

The location in the vehicle.  
(Instrument panel.)



Wear eye protection.



Wear heavy gloves.



Use an assistant.



Place the part on a blanket.



Work perpendicular.



Remove any burrs.



Use touch-up paint and allow to dry.



Tighten to the specified torque.



Apply firm pressure while rolling, especially at the ends, to set the adhesive.



Press firmly.



Clean with isopropyl alcohol.



Return the original part to the customer.  
(Do not reuse.)

## Safety: General

- Observe all safety notes and precautions described in the service information, in addition to those described in this Installation Instruction. Be extremely careful for your safety and safety of others.
- Use a tire changer to install and remove the tires according to the directions in the operation manual furnished with the tire changer. Do not use a tire lever to install and remove the tires as it may cause damage to the tire and aluminum wheel.
- Follow the instructions in the online owner's manual when raising the vehicle, and when removing and installing the wheels. Do not overtighten the wheel nuts.
- Be careful not to damage the vehicle or the parts.
- When using wheel balancer, refer to the Owner's Manual of used machinery.
- The illustrations may differ slightly from the actual accessory.





# Germain Honda of College Hills

## Safety: Accessory

- The illustration is an example. It may differ from the actual parts such as shapes.
- This aluminum wheel is designed for use on a vehicle equipped with a tire pressure monitoring system (TPMS).
- This aluminum wheel is equipped with a tire pressure sensor. See the service information for the tire replacement and sensor installation procedures.
- Always install the correct sized tires specified in the tire pressure caution plate.
- Always use the specified wheel nuts and wheel lock nuts.
- The standard wheel nuts may not be used with the aluminum wheels. Replace them with the correct wheel nuts which are sold separately as described below.
- Always use the parts and tools specified in the installation instructions.

## PARTS LIST

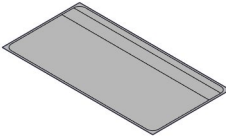
Aluminum Wheel Kit  
 (P/N 08W18-T90-100)  
 (P/N 08W18-T90-100A)  
 (P/N 08W18-T90-P00)  
 (P/N 08W18-T90-P00A)

|                                                                                                                                                                    |                                                                                                                                                                           |                                                                                                                                                                                 |                                                                                                                                |
|--------------------------------------------------------------------------------------------------------------------------------------------------------------------|---------------------------------------------------------------------------------------------------------------------------------------------------------------------------|---------------------------------------------------------------------------------------------------------------------------------------------------------------------------------|--------------------------------------------------------------------------------------------------------------------------------|
| <p>Aluminum wheel<br/>(The illustration may differ from the actual wheel.)</p>  | <p>Wheel center cap<br/>(The illustration may differ from the actual center cap.)</p>  | <p>Wheel cleaning information<br/>(Make sure your customer receives this information.)</p>  | <p>TPMS sensor<br/>(Sold separately.)</p>  |
|--------------------------------------------------------------------------------------------------------------------------------------------------------------------|---------------------------------------------------------------------------------------------------------------------------------------------------------------------------|---------------------------------------------------------------------------------------------------------------------------------------------------------------------------------|--------------------------------------------------------------------------------------------------------------------------------|

## REQUIRED TOOLS AND SUPPLIES

- Ratchet
- Shop towel
- 22 mm Socket
- Valve insert tool
- Torque wrench
- Lubricant

## SPECIFICATIONS

|               |                                                                                |                  |
|---------------|--------------------------------------------------------------------------------|------------------|
| Rim size      | 18 x 8J (inset 50)                                                             |                  |
| Tire size     | 255/60R18 108H (Except TrailSport Trim)<br>265/60R18 110T AT (TrailSport Trim) |                  |
| Bolt hole PCD | 120 (5 holes)                                                                  |                  |
| Tire pressure | Front                                                                          | 35 psi (240 kPa) |
|               | Rear                                                                           | 35 psi (240 kPa) |

# Germain Honda of College Hills

## INSTALLATION

### NOTE

- The illustrations of the aluminum wheels are shown for reference purposes only.
- Install the correct size tire.
- The wheel nut torque is 94 lb-ft (127 N·m).

1. Apply lubricant or immerse.

### NOTE

Do not apply lubricant or immerse onto the housing assembly.

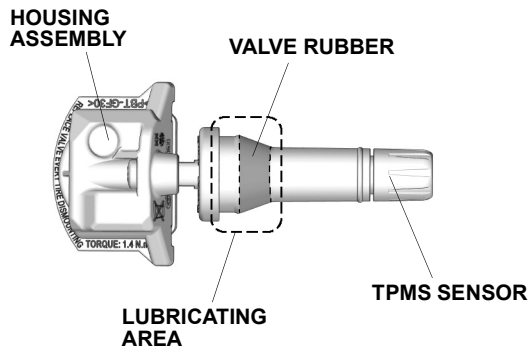

QH22103AH

2. Remove the valve cap.

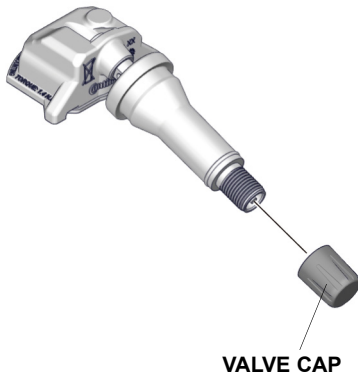

QH22104AH

3. Clean the TPMS sensor and aluminum wheel.

### NOTE

- Clean the mating surface.
- Make sure to install the TPMS sensor in the correct direction.

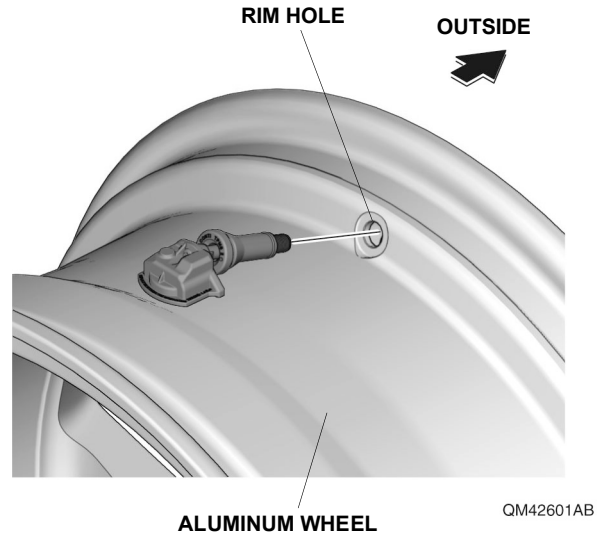

QM42601AB

4. Insert the TPMS sensor.
5. Install the valve insert tool.

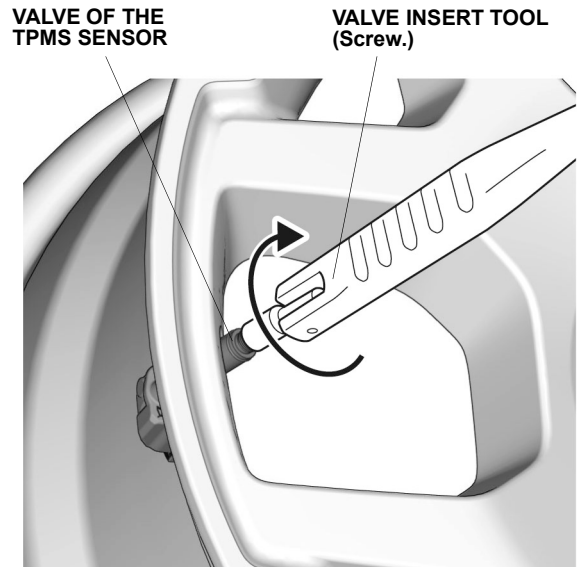

QM42602AB

# Germain Honda of College Hills

6. Pull the TPMS sensor valve.

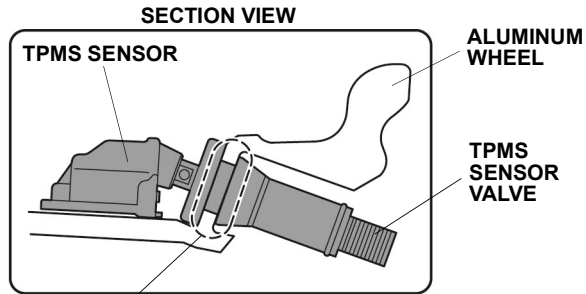

Make sure there is no gap in this area.

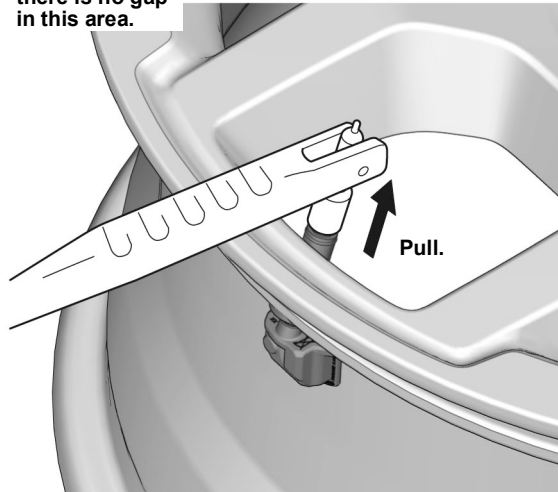

QM42603AB

7. Install the valve cap.

8. Check the TPMS sensor.

## NOTE

Keep angle between the tangent of the rim drop-well and bottom surface of the housing within  $-10^{\circ}$  to  $+10^{\circ}$  after insertion.

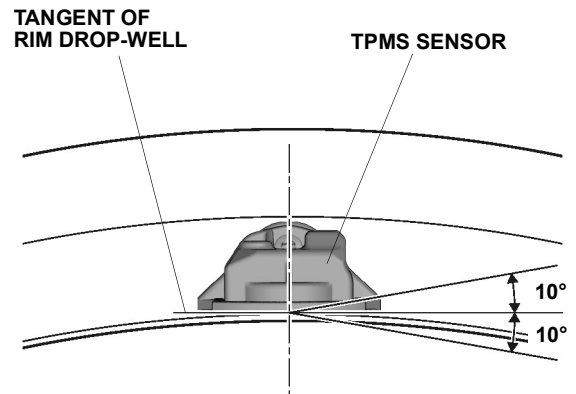

QJ80525AB

9. Install the tires.

## NOTE

- Check that there is no damage to the bead area.
- Use a lubricant to install the tires.
- Always adjust to the tire pressure specified in the tire pressure caution plate.

10. Install the wheel center caps.

11. Install the wheels.

## NOTE

The wheel nut torque is 94 lb-ft (127 N·m).

12. Drive the vehicle for at least 40 seconds at a speed of 15 mph (24 km/h) or more. All sensor IDs will be automatically memorized.
13. Check that all parts are installed properly.

## USE AND CARE

- Use a neutral detergent to clean the wheels.
- Rinse off the neutral detergent promptly after cleaning the wheels.