



INSTALLATION INSTRUCTIONS

Accessory
RUNNING BOARDS
 P/N 08L33-TG7-100
 P/N 08L33-TG7-100B

Application
2022 PILOT

Publications No.
VERSION 1
 Issue Date
JUL 2021

PARTS LIST

Left running board



Right running board



Left bracket A



Right bracket A



Left bracket C



Right bracket C



16 Flange bolts

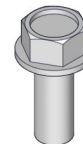

TOOLS AND SUPPLIES REQUIRED

- Ratchet
- File
- 13 mm Socket
- Torque wrench
- Utility knife
- Touch-up paint

Illustration of the Running Boards on the Vehicle

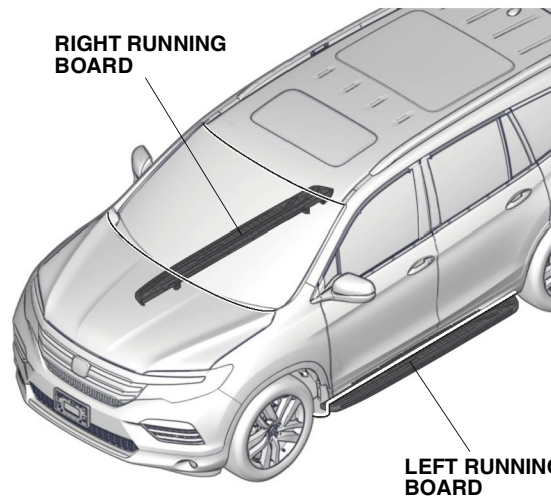

QDN1402BC

INSTALLATION

Customer Information: The information in this installation instruction is intended for use only by skilled technicians who have the proper tools, equipment, and training to correctly and safely add equipment to your vehicle. These procedures should not be attempted by “do-it-yourselfers.”

NOTE:

- Thoroughly clean the bottom of the body between the front and rear wheels.
 - Be careful not to damage the body paint finish.
 - These instructions show the left side running board being installed; the same procedure applies to installing the right running board.
1. Locate the two presets in the left side sill panel. Using an utility knife, cut out the left side sill panel along the each preset. Remove any burrs.

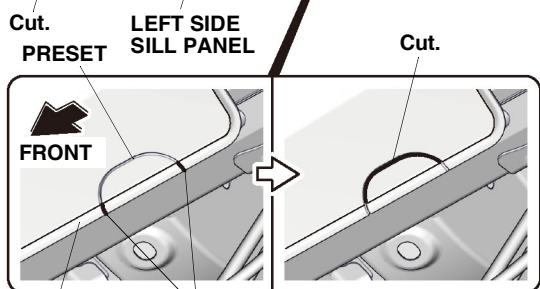
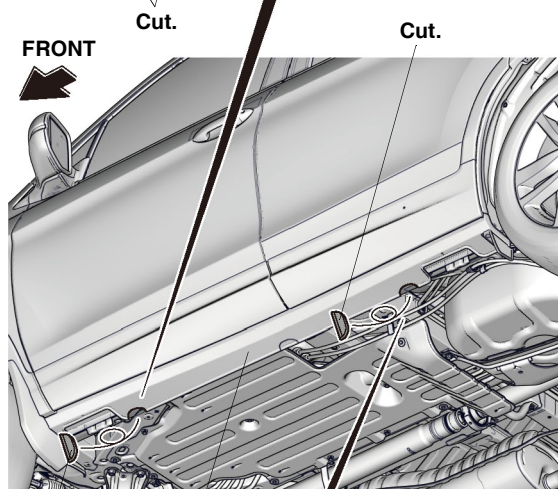
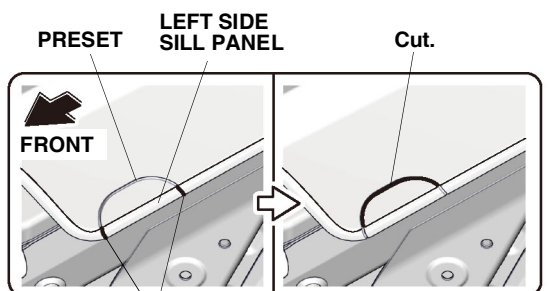

LEFT SIDE SILL PANEL Cut. QDN1701AC

2. Remove the undercoating in the areas shown. Apply touch-up paint to the areas where you removed the undercoating, and allow them to dry thoroughly.

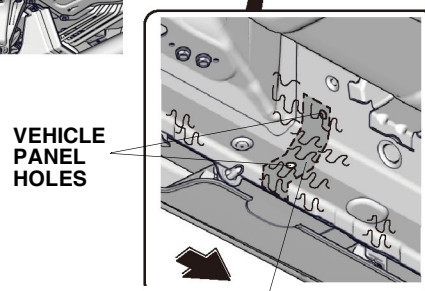
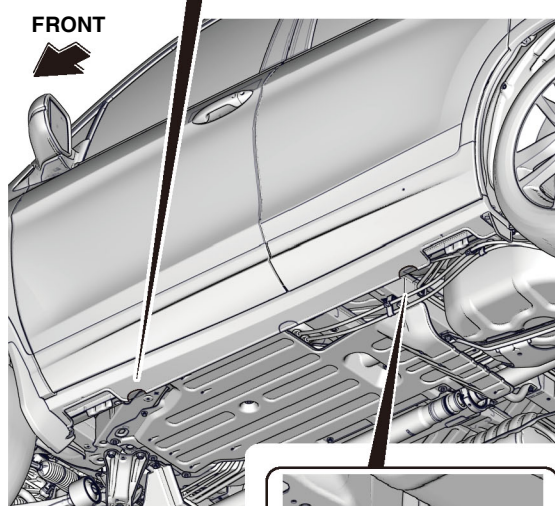
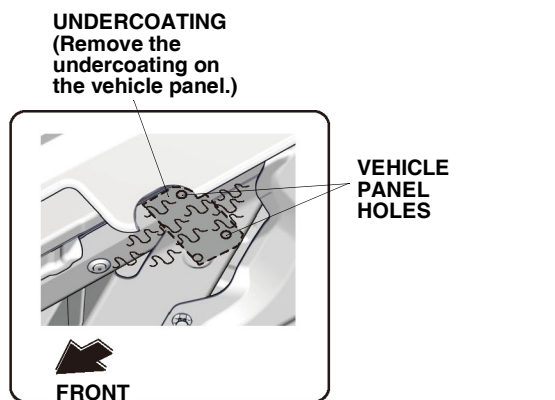

UNDERCOATING (Remove the undercoating on the vehicle panel.)

QE20403BC

3. Loosely secure the left bracket A and left bracket C to the vehicle panel with four flange bolts.

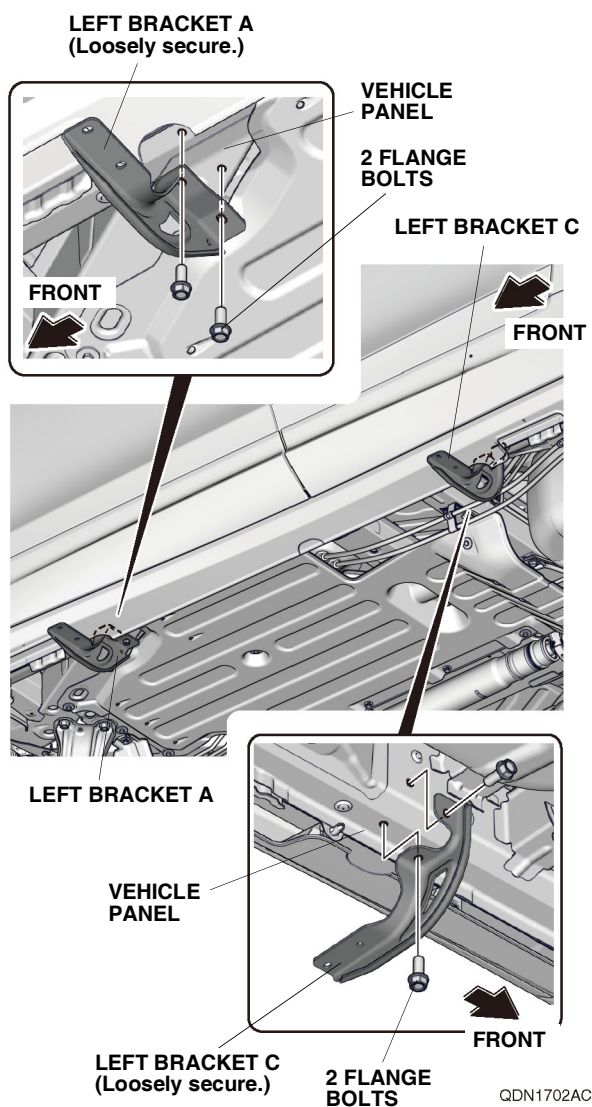

4. Secure the left running board to the left bracket A and left bracket C with four flange bolts. Torque the flange bolts to 27 N·m (20 lb·ft).
NOTE: Have an assistant help you when installing the running board.

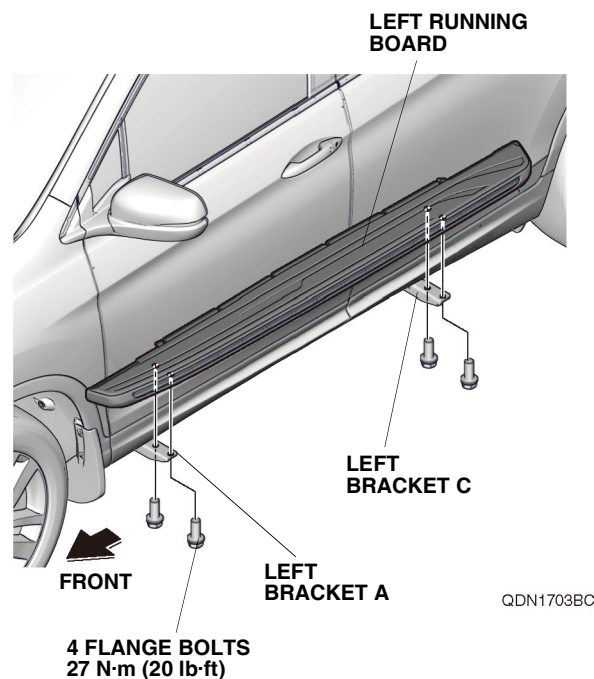

5. Tighten the four flange bolts loosely installed in step 3. Torque the flange bolts to 27 N·m (20 lb-ft).

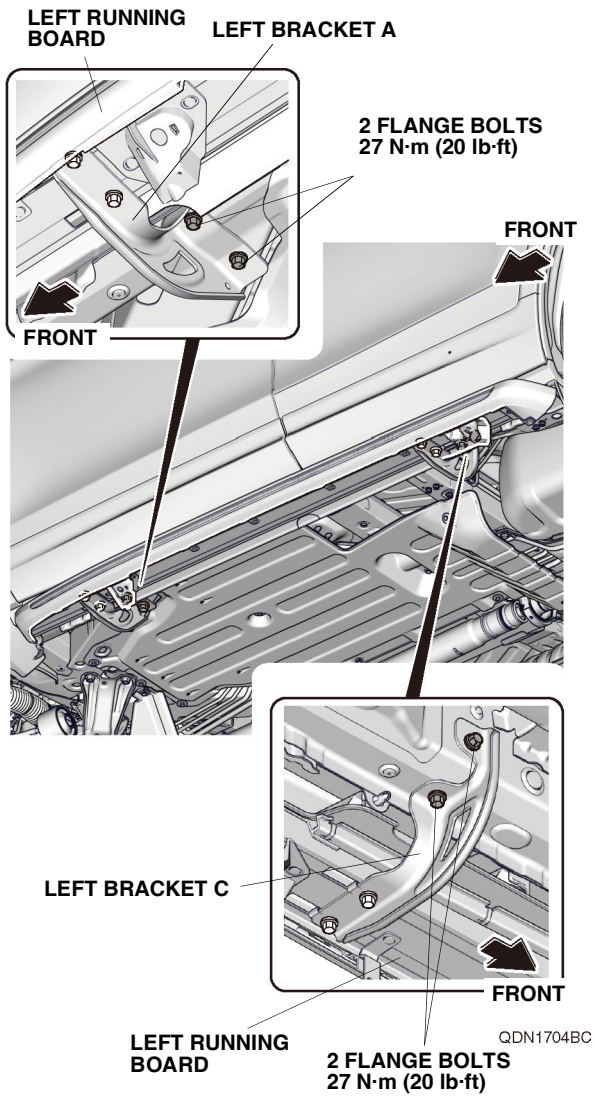

6. Repeat steps 1 through 5 on the right side of the vehicle to install the right running board.