



## INSTALLATION INSTRUCTIONS

Accessory  
TRAILER HITCH

Application  
2019 PILOT

Publications No.  
**VERSION 1**  
Issue Date  
**JUN 2018**

### PARTS LIST

**Trailer Hitch Kit**  
**P/N 08L92-TG7-1A0**

Trailer hitch



Trailer hitch cover



Receiver cover



6 Flange bolts



**Ball Mount Kit**  
**P/N 08L92-TG7-101A**

Ball mount



Hitch pin



Hitch pin clip



### TOOLS AND SUPPLIES REQUIRED

Shop towel

10 mm Open end wrench

Ratchet

Torque wrench

10 mm, 19 mm, and 22 mm Sockets

Phillips screwdriver

File

*The following tools are available through the Honda Tool and Equipment Program. On the iN, click on Service > Service Bay > Tool and Equipment Program, then enter the number under "Search." Or, call 888-424-6857.*

- Trim Tool Set (T/N SOJATP2014)
- Plastic Trim Tool (T/N SILTRIMTL10)
- Air saw (T/N AT192A)

### Illustration of the Trailer Hitch on the Vehicle



QH31301AC

## INSTALLATION

**Customer Information:** The information in this installation instruction is intended for use only by skilled technicians who have the proper tools, equipment, and training to correctly and safely add equipment to your vehicle. These procedures should not be attempted by “do-it-yourselfers.”

NOTE: If you are also installing the trailer hitch harness, install it before you install the trailer hitch.

1. Disconnect the negative cable from the battery:
  - Wrap a shop towel around the hood latch.

**HOOD LATCH**  
(Wrap with a shop towel.)

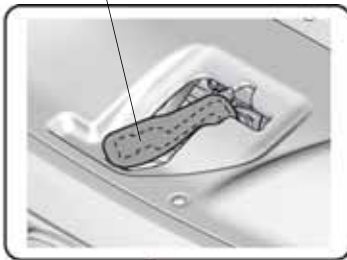

QH21201AB

- Remove the front bulkhead cover.

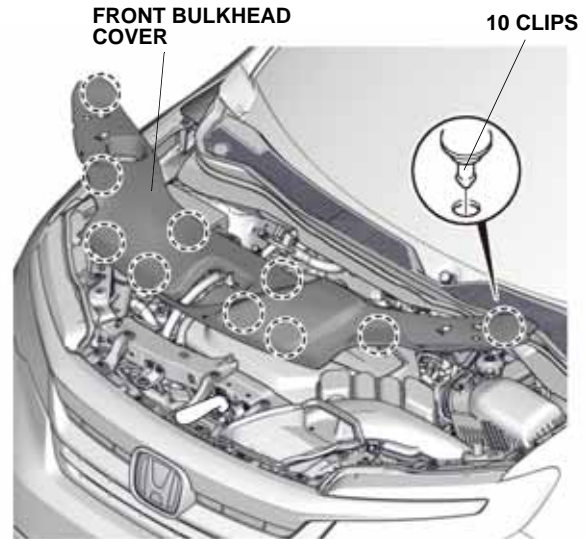

QH21202AB

- Remove the intake air tube.
- Disconnect the negative cable from the battery.

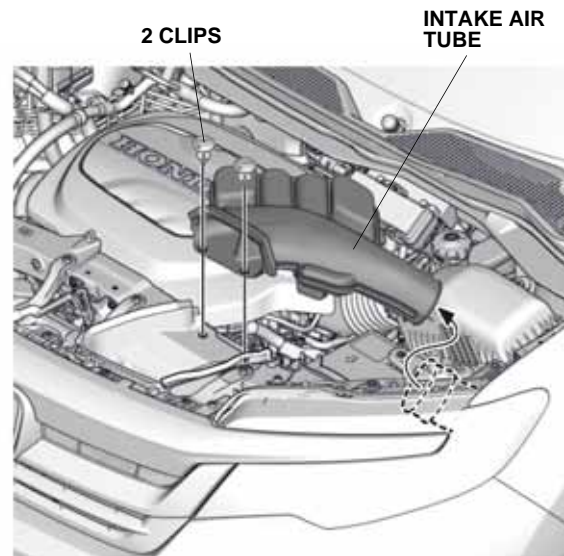

QH21203AB

2. Remove the cargo lid.

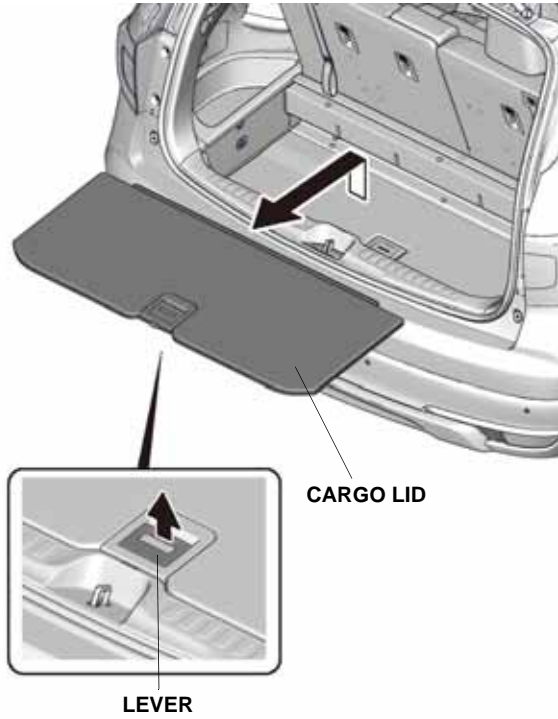

3. Remove the spare tire plug cap.

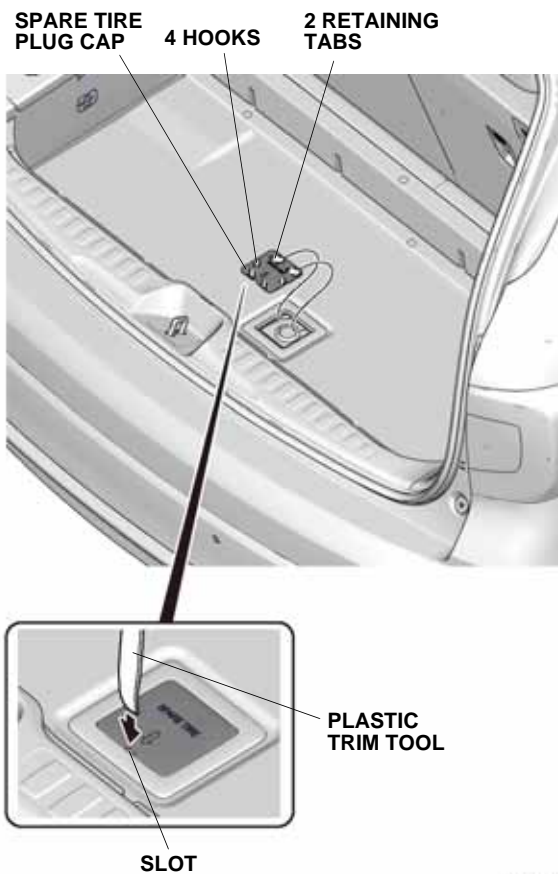

4. Remove the spare tire plug to access the spare tire hoist shaft. Lower the spare tire completely.

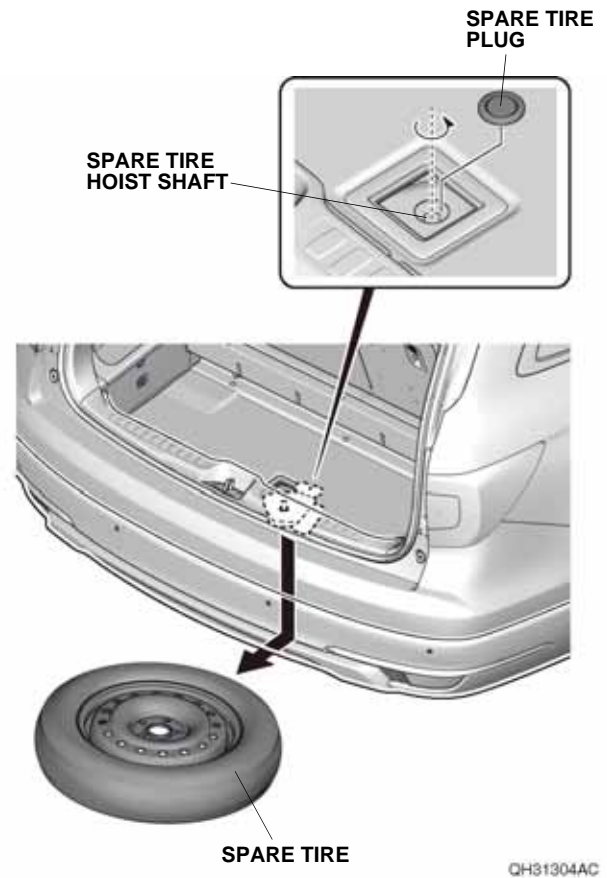

- Remove the rear bumper lower cover and unplug the vehicle connector (if equipped).

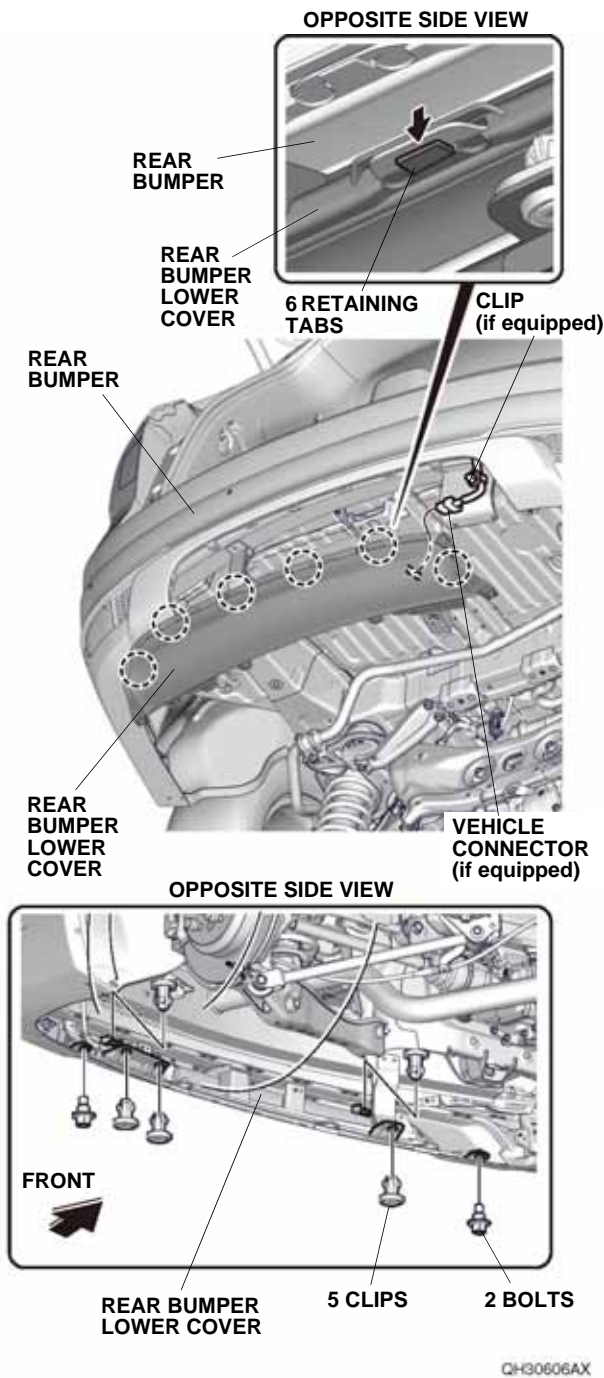

- Remove the two spring nuts from the rear bumper lower cover. If the vehicle is equipped with the standard hands-free access power tailgate, also remove the two self-tapping screws and one clip as shown.

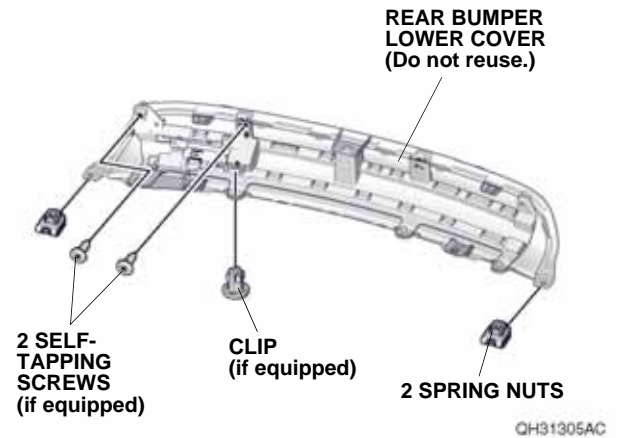

If you are also installing the Hands-Free Access Power Tailgate Kit, continue with step 7; otherwise, go to step 12.

### With accessory Hands-Free Access Power Tailgate Kit

- Release the two sensor bars on the accessory hands-free access unit.

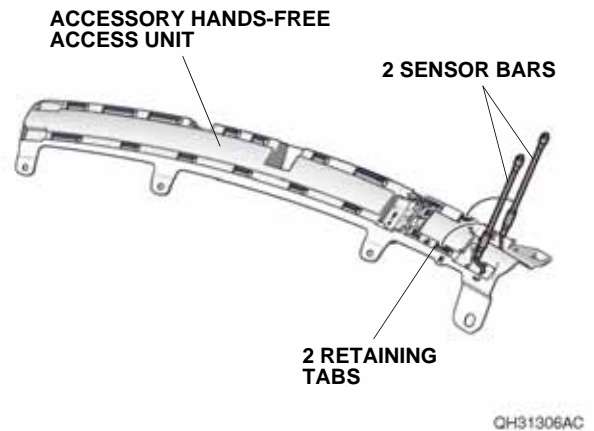



8. While wearing eye protection, use an air saw to cut the accessory hands-free access unit along the scribe line. Remove any burrs.  
NOTE: Be careful not to cut sensor bars. If sensor bars are damaged, they must be replaced.

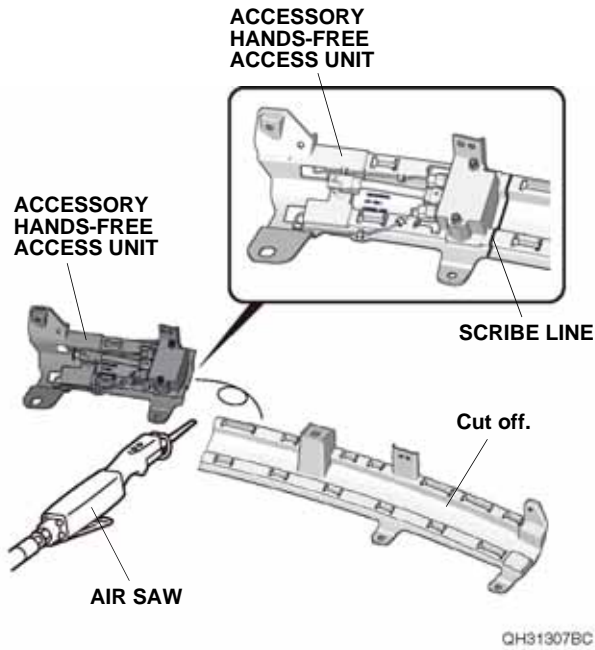

9. Install the two sensor bars to the accessory hands-free access unit. Make sure the sensor bars are positioned and their wires are secured as shown.

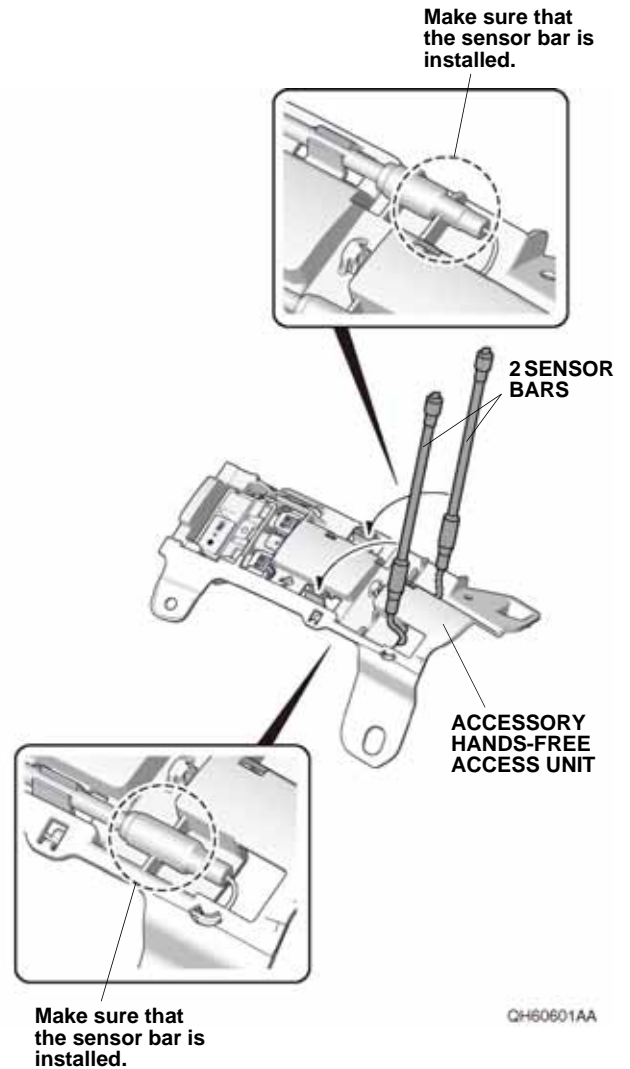

10. Make sure the sensor bar wires are secured as shown.

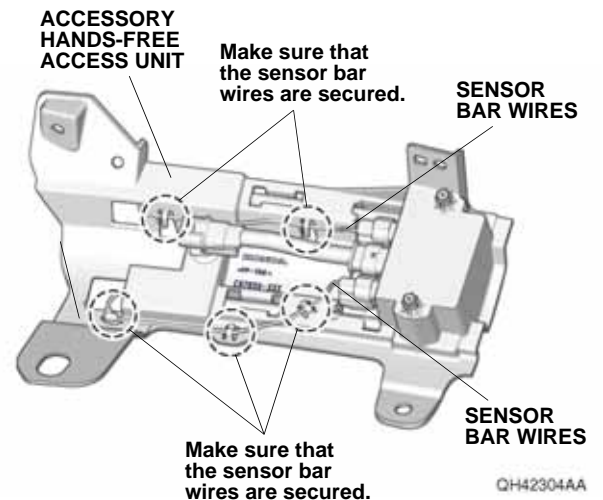

11. Install the accessory hands-free access unit to the trailer hitch cover. If the vehicle is equipped with the standard hands-free access power tailgate, use two self-tapping screws and one clip removed in step 6; if not, use new two self-tapping screws and one clip in the kit.

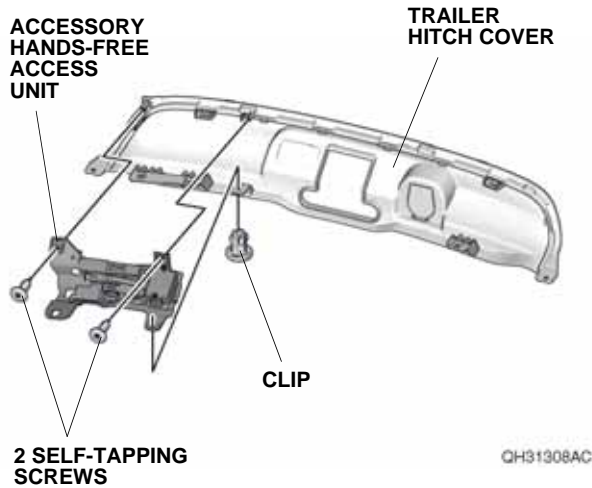

12. Install the two spring nuts removed in step 6 to the trailer hitch cover.  
NOTE: Make sure to install the spring nuts as shown.

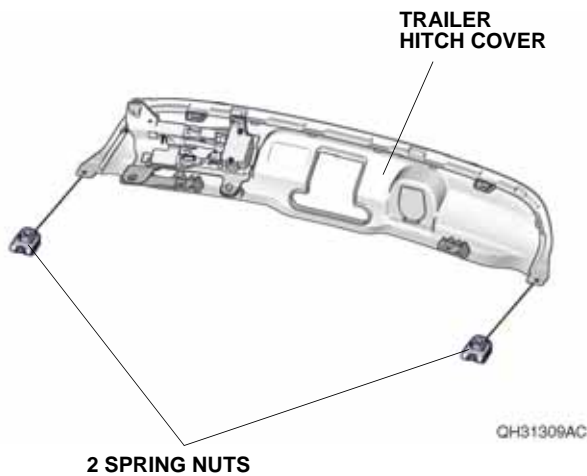

13. If equipped, plug the vehicle connector and secure the clip on the vehicle harness to the trailer hitch cover. Install the trailer hitch cover to the rear bumper with six retaining tabs, five clips, and the two bolts removed in step 5.

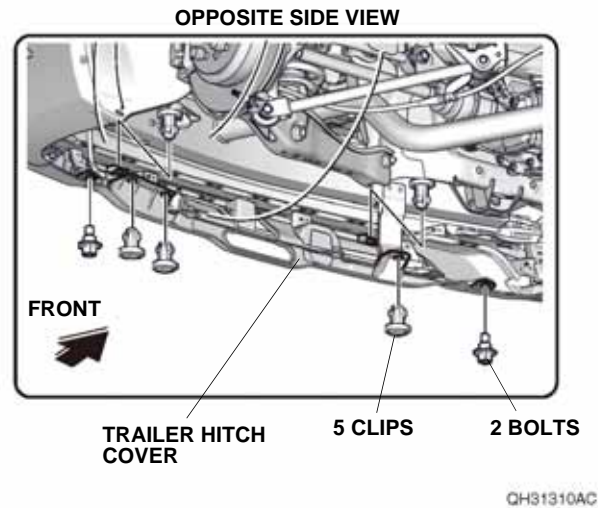
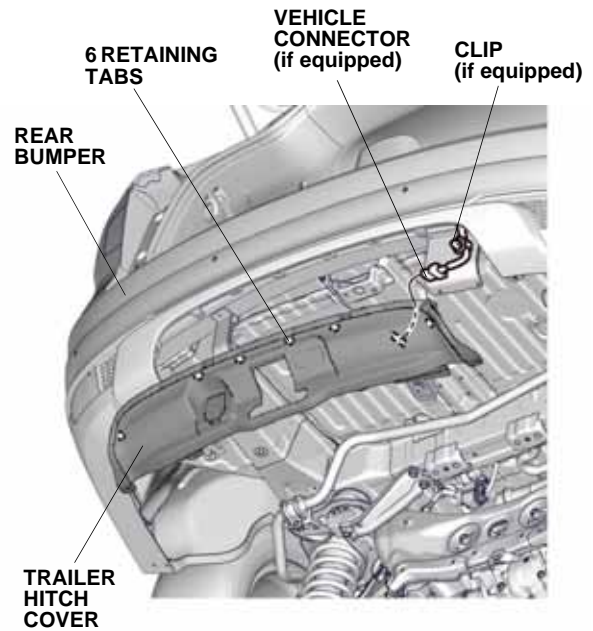

14. With the help of an assistant, loosely secure the trailer hitch to the vehicle with the six flange bolts.

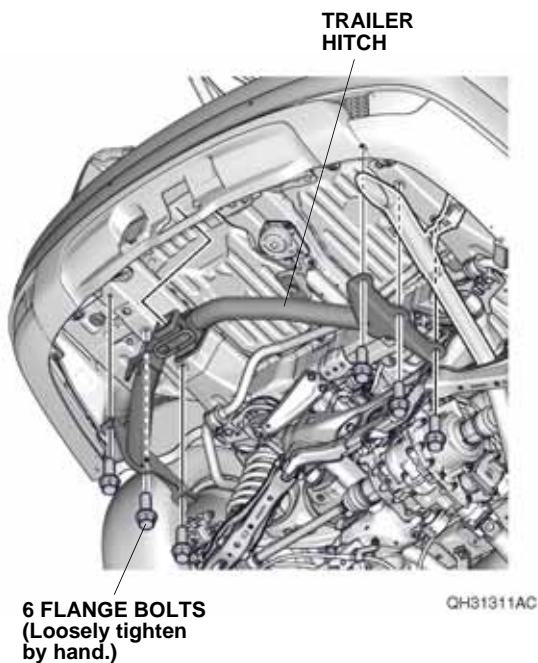

15. Tighten the six flange bolts to an initial torque of 32 lb-ft (43 N·m) as shown. Then, tighten the bolts to a final torque of 63 lb-ft (85 N·m).  
NOTE: After tightening all the bolts, recheck their torque.

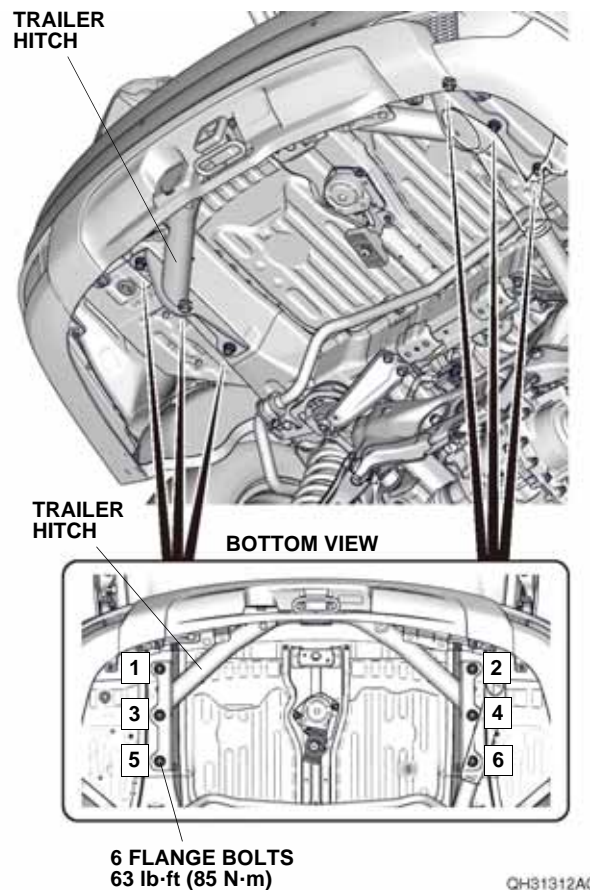

16. Check that all wire harnesses are routed properly and all connectors are plugged in.
17. Install all removed parts except for the spare tire, front bulkhead cover, and the intake tube.
18. Connect the negative cable to the battery.
19. Install the front bulkhead cover and the intake air tube.
20. Press and hold the audio unit power button for 2 seconds to restore the audio and navi (if equipped) system functions.
21. Set the clock on vehicles without navigation.
22. If necessary, restore the systems back to normal operation as described in the service information.

## 23. Spare Tire Installation:

- Before raising the spare tire back into the vehicle, make sure the spare tire hoist bar is centered in the hub opening of the wheel.
- Raise the spare tire. If the hoist bar is correctly positioned, the spare tire will be close to level as it is raised. If the hoist bar is not correctly positioned, the spare tire will not be level as it is raised and will not seat flush under the vehicle.
- Using the appropriate tools in the vehicle, tighten the spare tire hoist until it clicks. Failure to do this can result in noise and/or damage to the hoist cable.

### INCORRECT:

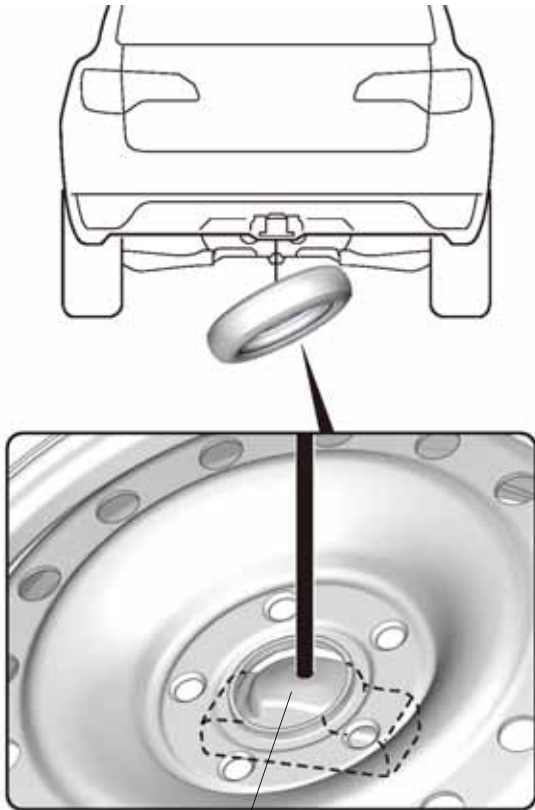

Bracket position is incorrect.

QH30002AR

### CORRECT:

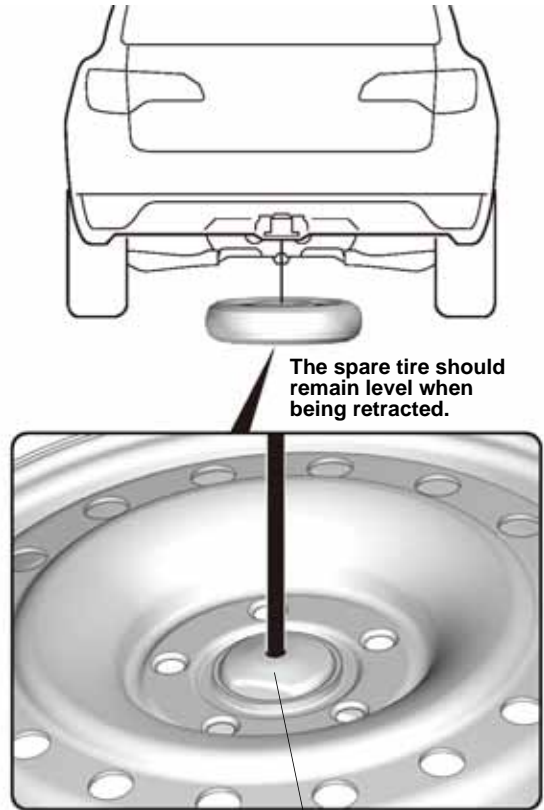

The spare tire should remain level when being retracted.

Bracket position is correct. QH30001BR



Put a copy of this page in the glove box for your customer.

Whenever you remove the hitch pin clip, the hitch pin, and the ball mount, store them securely in the cargo area. Install the receiver cover into the opening at the end of the trailer hitch. When you reinstall the ball mount, store the receiver cover in the cargo area.

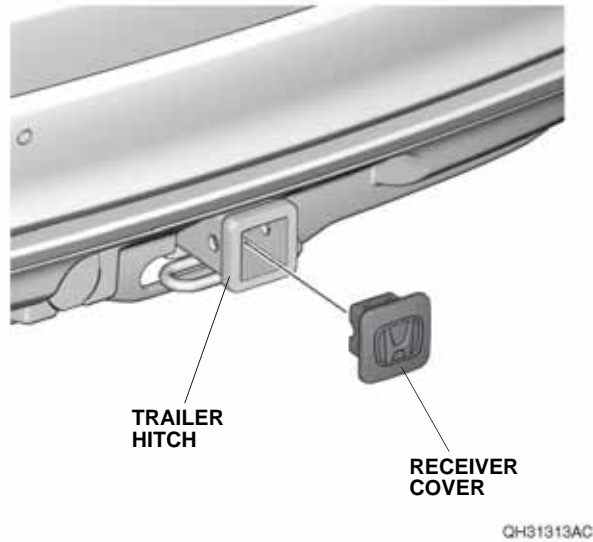

Install the ball mount into the trailer hitch using a hitch pin clip and hitch pin.

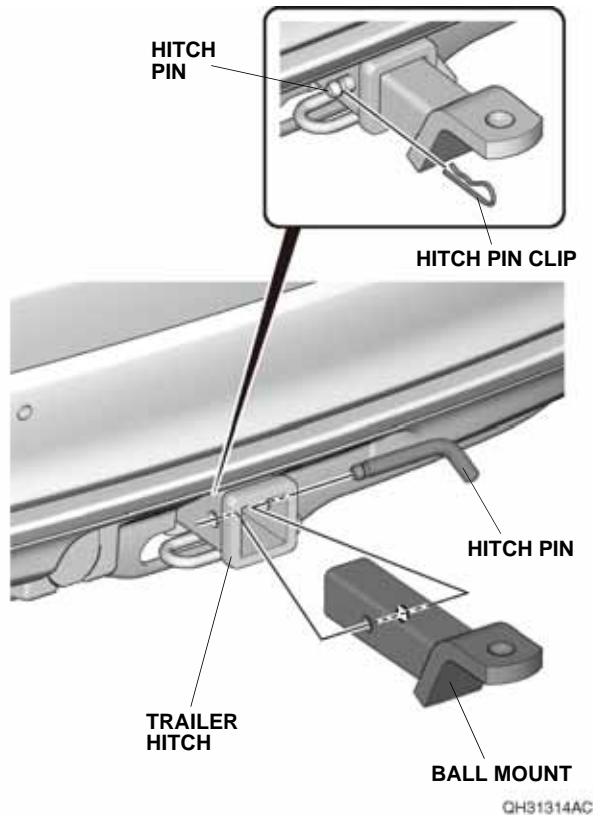

After the first 600 miles (1,000 km) of towing, have your Honda Dealer check the tightness of the trailer hitch bolts.