



INSTALLATION INSTRUCTIONS

Accessory	Application	Publications No.
DOOR VISORS P/N 08R04-TG7-100	2018 PILOT	VERSION 1
		Issue Date OCT 2017

PARTS LIST

Left front door visor



Right front door visor



Left rear door visor



Right rear door visor



8 Brackets A



2 Brackets B



4 Alcohol swabs



10 Clips



TOOLS AND SUPPLIES REQUIRED

Masking tape

Ruler

Illustration of the Door Visors on the Vehicle

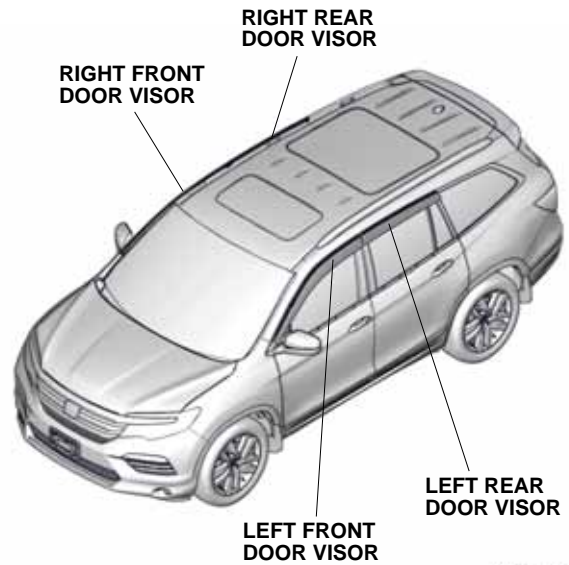

QDN1101AC

INSTALLATION

Customer Information: The information in this installation instruction is intended for use only by skilled technicians who have the proper tools, equipment, and training to correctly and safely add equipment to your vehicle. These procedures should not be attempted by “do-it-yourselfers.”

NOTE:

- Be careful not to damage the body paint finish and glass run channels when installing the door visors.
- Handle the door visors with care. They are not designed to absorb shock or impact.
- This kit should be installed only if the ambient air temperature is 15°C (60°F) or above.
- To allow the adhesive to cure, do not wash the vehicle for 24 hours. Please advise the customer.

Installing the Front Door Visor

1. Fully open the left front door glass.

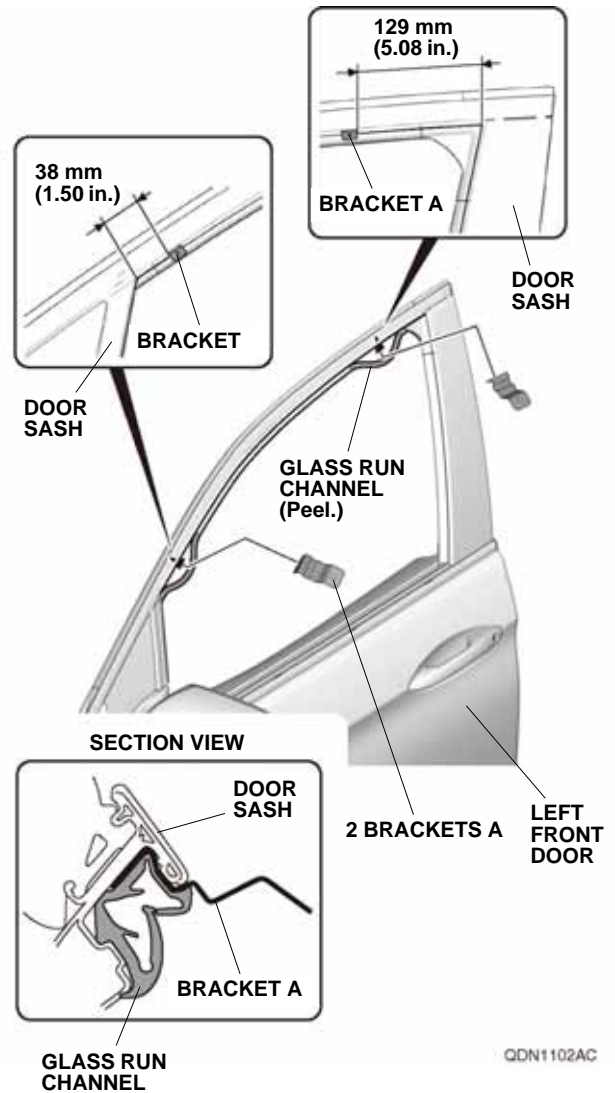

2. Pull back the glass run channel.
3. Install two brackets A to the door sash as shown.
4. Install the glass run channel and secure the two brackets A. Check that the two brackets A are installed on the door sash as shown. Check that the glass run channel is installed properly.

5. Insert one bracket B into the door sash as shown.

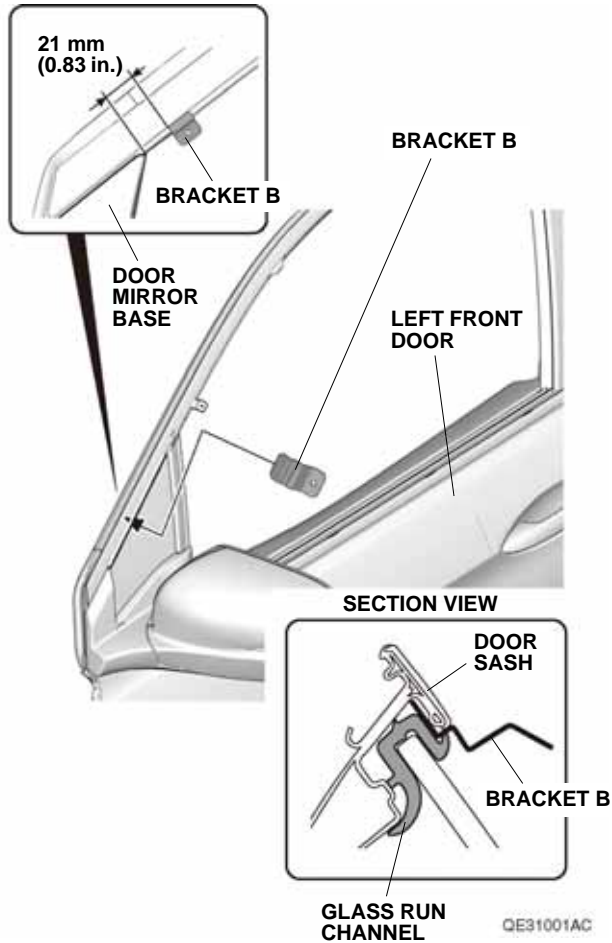

6. Using an alcohol swab, thoroughly clean the area where the left front door visor will attach.

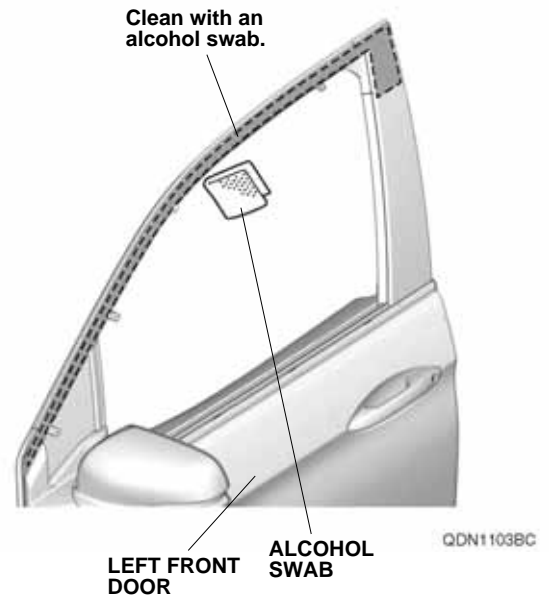

7. Attach a piece of masking tapes to the end of the adhesive backings as shown. Peel back the adhesive backings partway and temporarily attach them to the front surface of the left front door visor.

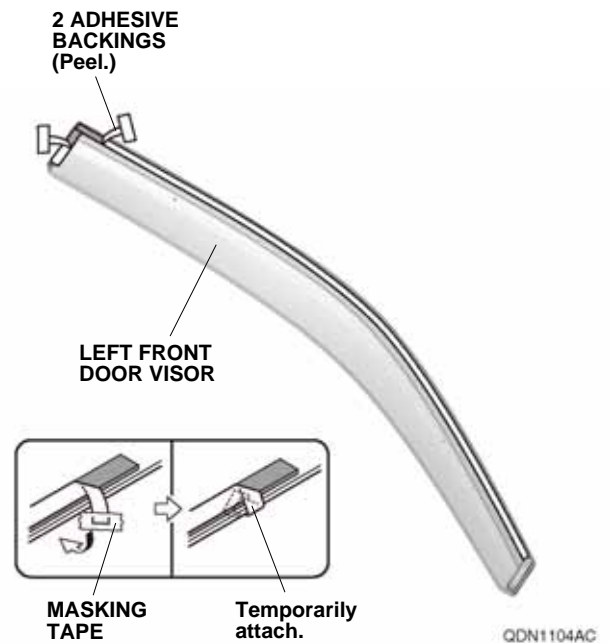

8. Adjust the two brackets A and one bracket B so the holes line up with the three holes on the left front door visor.

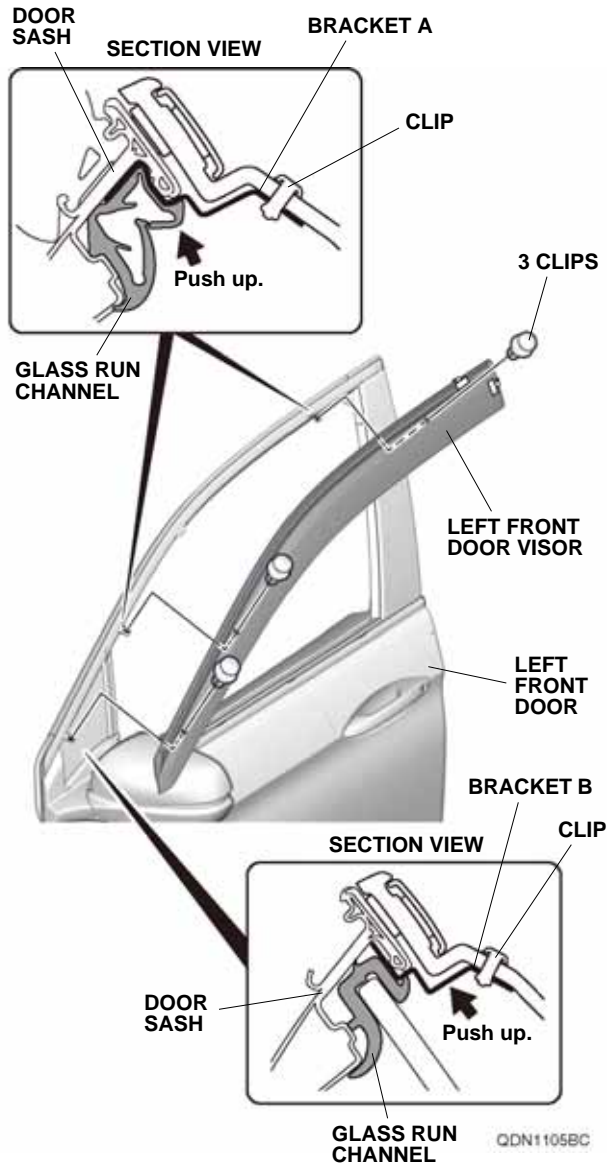

10. Line up the left front door visor as shown.

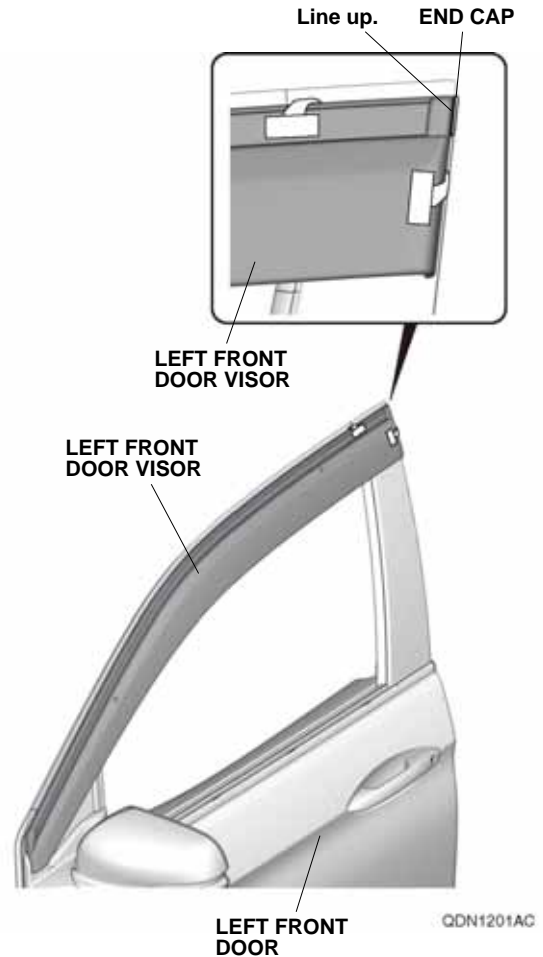

9. Secure the left front door visor to two brackets A and one bracket B with three clips. Make sure to push up on the two brackets A and one bracket B while installing the clips.
NOTE: The clips cannot be removed and reinstalled after installation.

- While applying light pressure against the left front door visor, carefully remove the taped adhesive backings. Make sure to push up on the brackets A and bracket B while removing the adhesive backings.

NOTE: While removing long top piece of adhesive backing, make sure that left front door visor is positioned so that top edge of vehicle chrome is hidden by left front door visor.

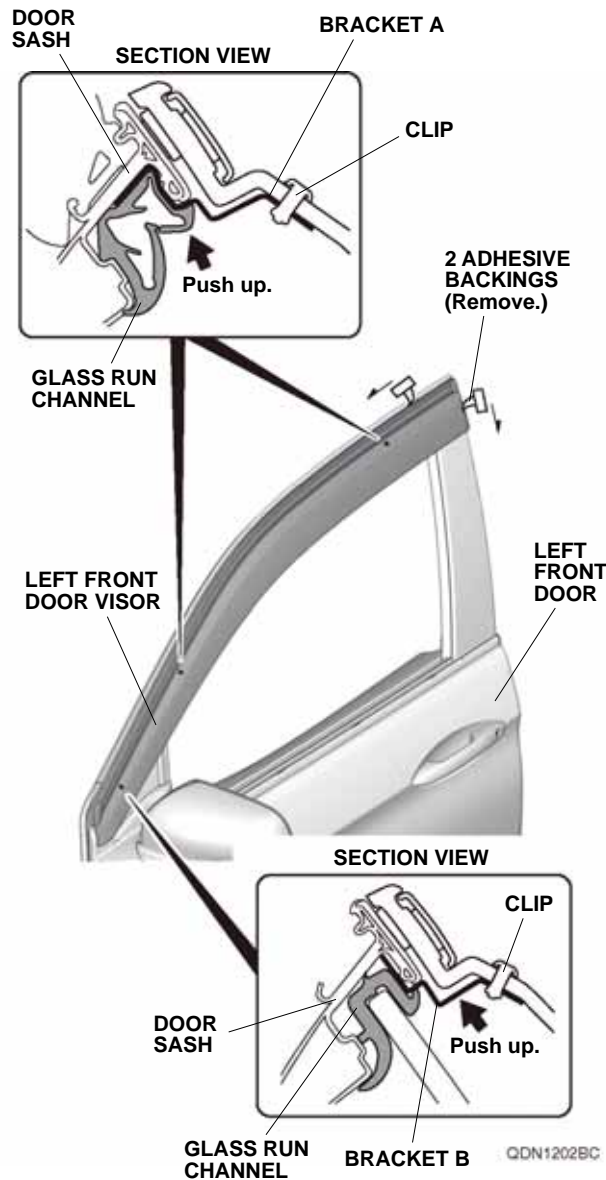

- Using the palm of your hand, firmly press the left front door visor against the door sash.

Installing the Rear Door Visor

- Fully open the left rear door glass.

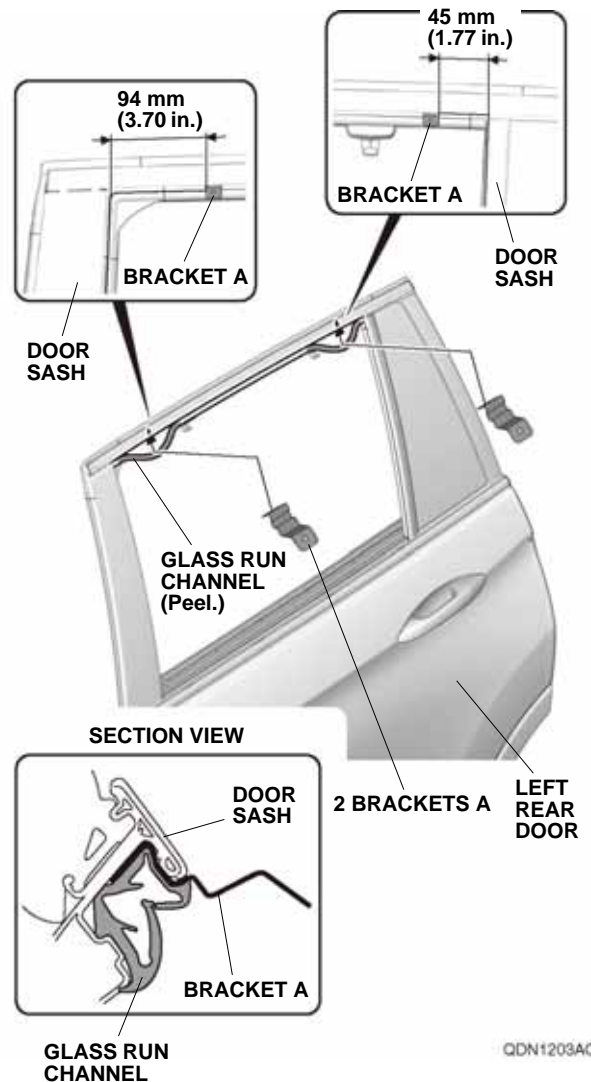

- Pull back the glass run channel.
- Install two brackets A onto the door sash as shown.
- Install the glass run channel and secure the two brackets A. Check that the two brackets A are installed on the door sash as shown. Check that the glass run channel is installed properly.

17. Using an alcohol swab, thoroughly clean the area where the left rear door visor will attach.



18. Attach a piece of masking tapes to the end of the adhesive backings as shown. Peel back the adhesive backings partway and temporarily attach them to the front surface of the left rear door visor.

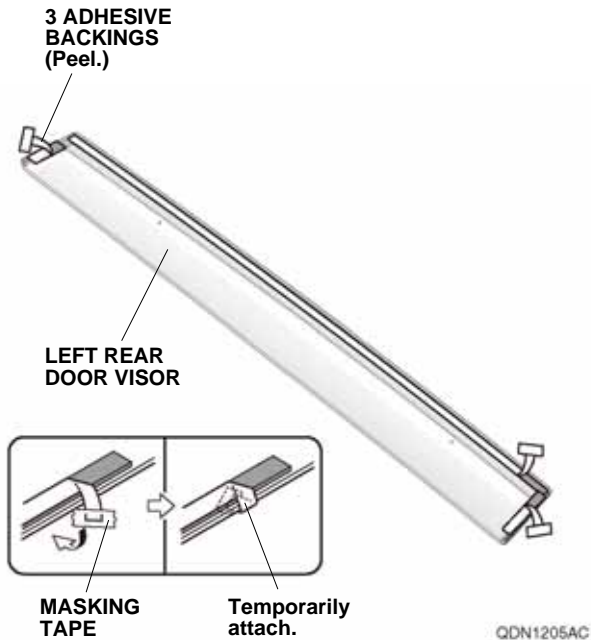

19. Adjust the two brackets A so the holes line up with the two holes on the left rear door visor.

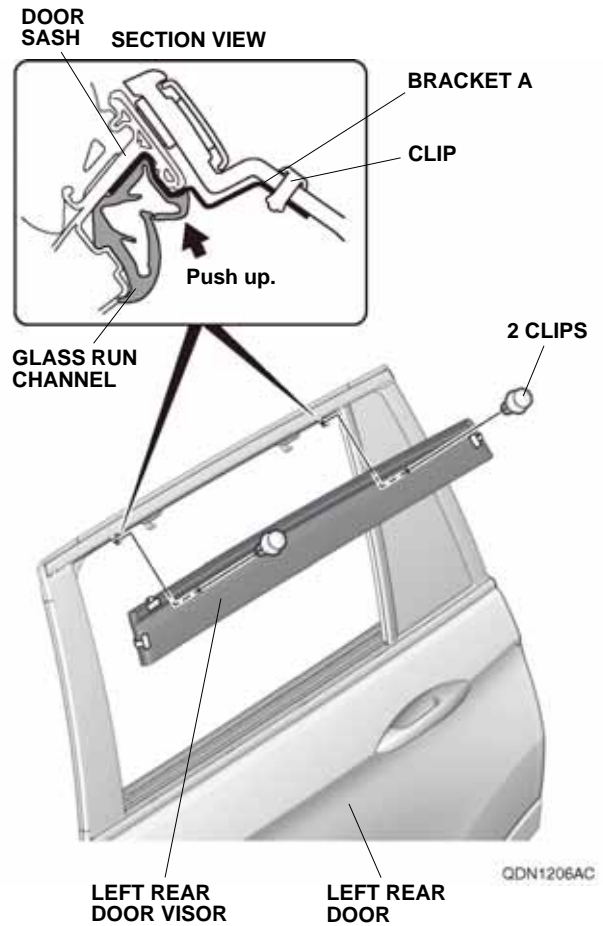

20. Secure the left rear door visor to two brackets A with two clips. Make sure to push up on the two brackets A while installing two clips. NOTE: The clips cannot be removed and reinstalled after installation.

21. Line up the left rear door visor as shown.

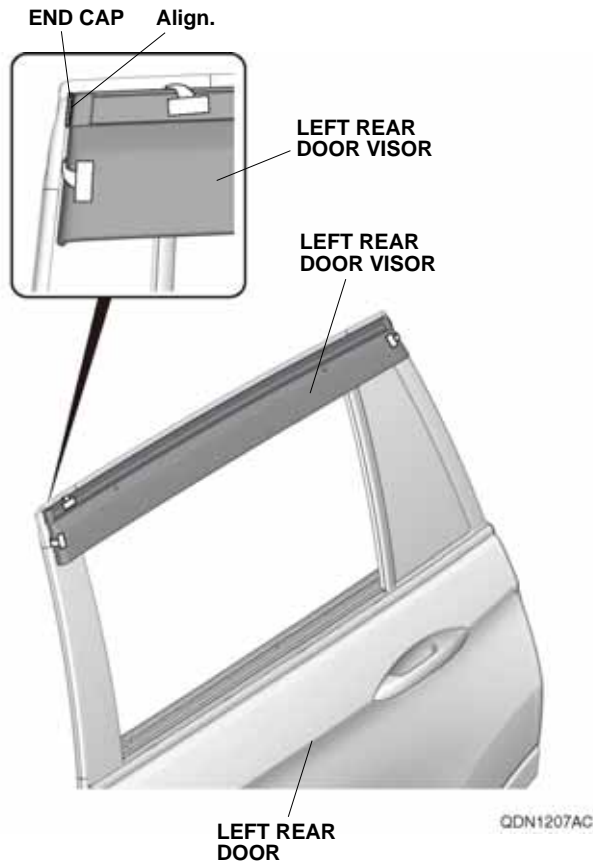

22. While applying light pressure against the left rear door visor, carefully remove the taped adhesive backings. Make sure to push up on the two brackets A while removing the adhesive backings. NOTE: While removing long top piece of adhesive backing, make sure that left rear door visor is positioned so that top edge of vehicle chrome is hidden by left rear door visor.

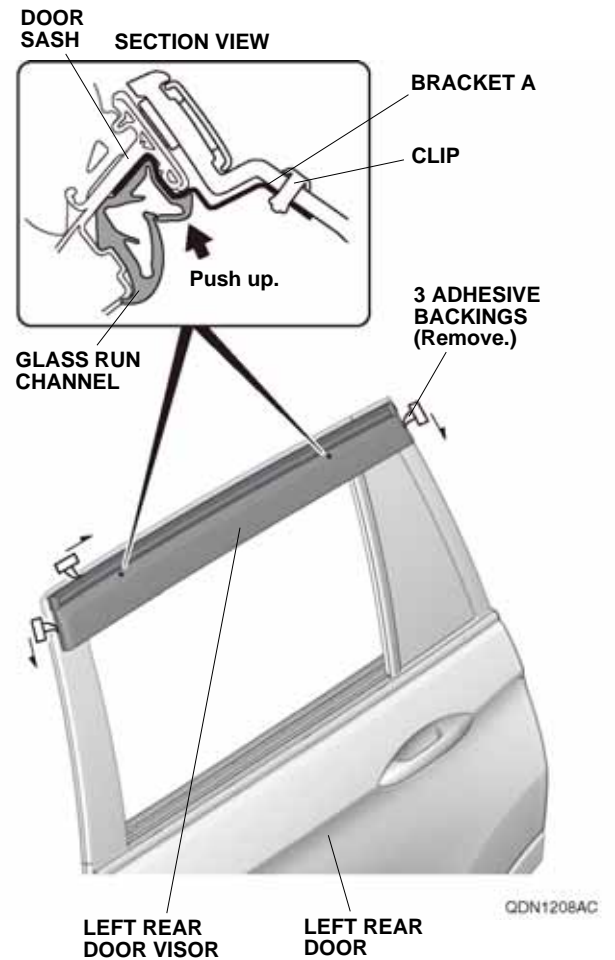

23. Using the palm of your hand, firmly press the left rear door visor against the door sash.
24. Repeat steps 1 through 23 on the right side of the vehicle.

CONFIRMATION AFTER INSTALLATION

RESTORATION OPERATIONS

1. Start the engine.
 2. Using the power window switch, fully open the window, and make sure the run channel is not pinched, etc.
 3. Using the power window switch, repeat opening and closing of the window from half-open to fully closed four or five times to allow the run channel to wear seat.
 4. Refer to the service manual, to reset the power windows. (If the automatic closing/opening does not function after the reset, reset again.)
 5. Refer to the service manual, to perform the power window "learning" procedure. (If the automatic closing/opening does not function after the learning, carry out "learning" again.)
- The operations in the steps 4 and 5 should be applied to all power windows having the automatic closing/opening function to allow for proper functioning of the auto-reverse feature.

USE AND CARE

- When the door visor is dirty, clean it with a soft damp cloth.
- If the door visor is very dirty, clean the visor with neutral detergent and water. Do not use volatile solvent (e.g. thinner, benzine, alcohol, etc.) or a cleaner containing abrasive material.