



INSTALLATION INSTRUCTIONS

Accessory SPLASH GUARDS P/N 08P00-TG7-100	Application 2017 PILOT	Publications No. VERSION 1
		Issue Date OCT 2016

PARTS LIST

Left front splash guard



Right front splash guard



Left rear splash guard



Right rear splash guard



4 Spring nuts



8 Self-tapping screws, 5 x 20 mm



TOOLS AND SUPPLIES REQUIRED

Phillips screwdriver

Stubby Phillips screwdriver

Pushpin

Illustration of the Splash Guards on the Vehicle



INSTALLATION

Customer Information: The information in this installation instruction is intended for use only by skilled technicians who have the proper tools, equipment, and training to correctly and safely add equipment to your vehicle. These procedures should not be attempted by “do-it-yourselfers.”

NOTE:

- Do not damage the paint finish.
- Clean and wax the areas to be covered with a high quality paste wax.

Installing the Front Splash Guards

1. Turn the steering wheel fully counterclockwise.

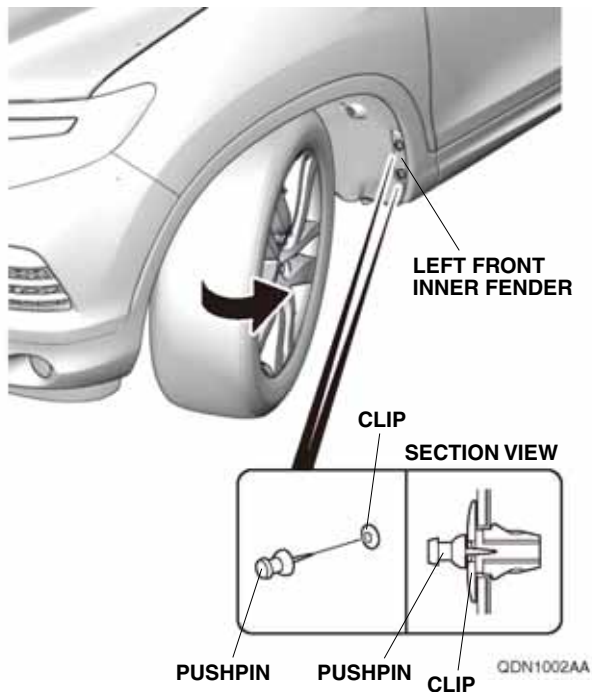

2. Using a pushpin, pierce the center of the top two clips on the left front inner fender.
3. Remove the self-tapping screw from the left front inner fender.

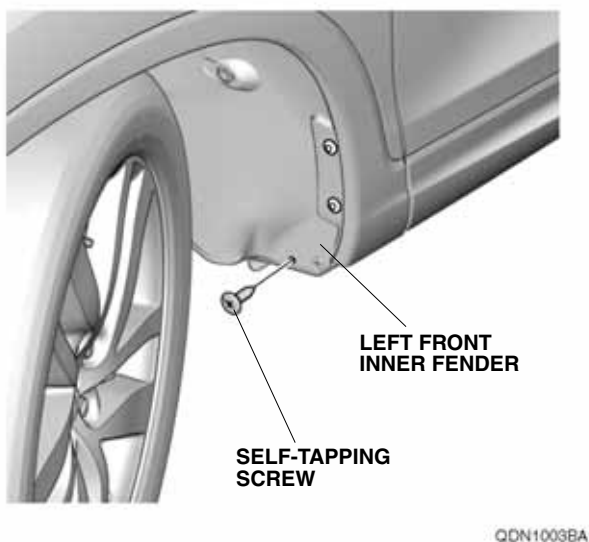

4. Loosely secure the left front splash guard on the left front inner fender with two 5 x 20 mm self-tapping screws and the self-tapping screw removed in step 3.

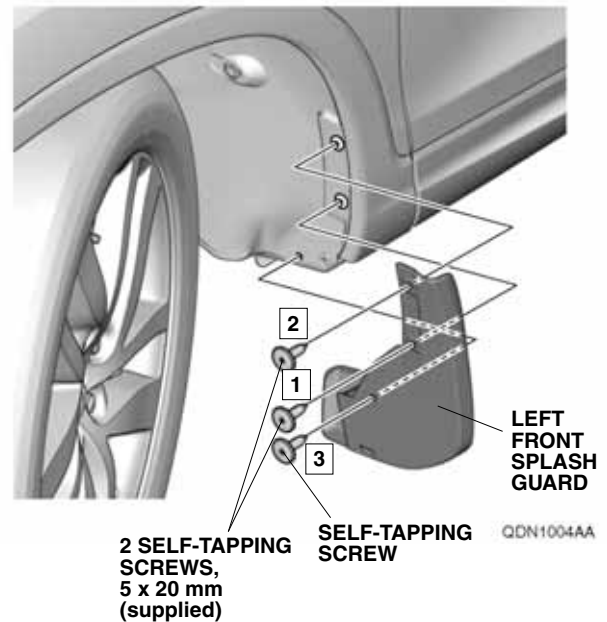

5. While holding the left front splash guard against the left front inner fender, tighten self-tapping screws in the order shown.
NOTE: Make sure there is no gap between the left front splash guard and the vehicle body. If there is a gap, loosen the self-tapping screws, hold the splash guard against the body, and retighten the screws.
6. Turn the steering wheel fully clockwise, and repeat steps 2 through 5 to install the right front splash guard.

Installing the Rear Splash Guards

7. Remove the two self-tapping screws from the rear bumper.

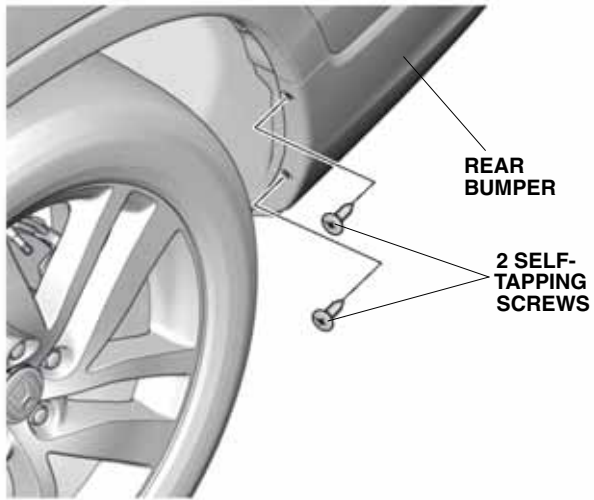

QDN1005BA

8. Install one spring nut on the left rear splash guard in the area shown.

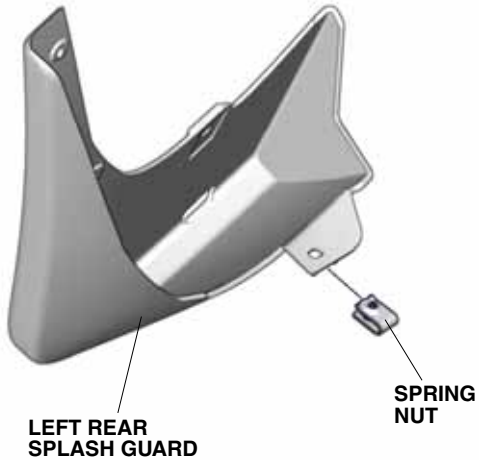

QDN1006AA

9. Install one spring nut on the left rear inner fender through the hole shown.

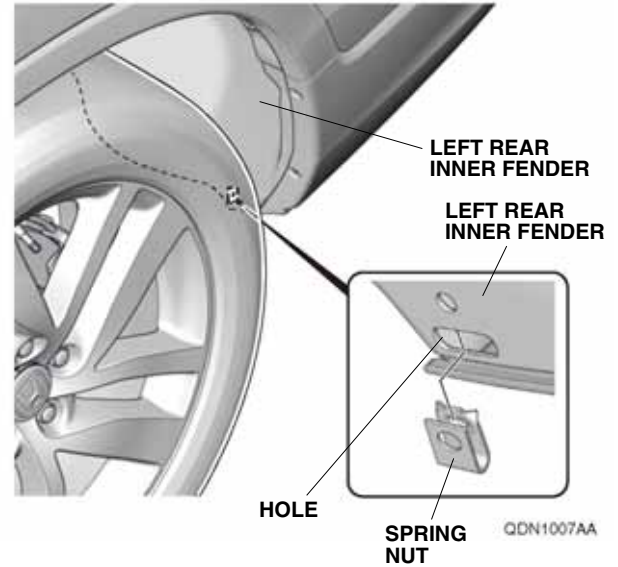

QDN1007AA

- Loosely install the left rear splash guard to the rear bumper and left rear inner fender with two 5 x 20 mm self-tapping screws and the two self-tapping screws removed in step 7.

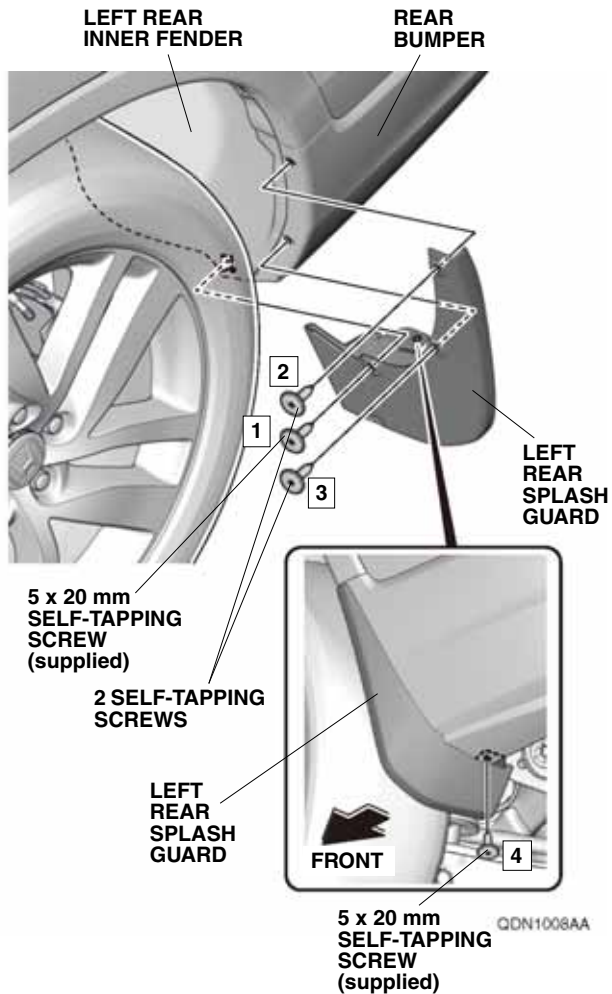

- While holding the left rear splash guard against the rear bumper and left rear inner fender, tighten self-tapping screws in the order shown.
NOTE: Make sure there is no gap between the left rear splash guard and the vehicle body. If there is a gap, loosen the self-tapping screws, hold the splash guard against the body, and retighten the screws.
- Repeat steps 7 through 11 to install the right rear splash guard.