



**INSTALLATION
INSTRUCTIONS**

Accessory
REAR LOWER TRIM
P/N 08P46-TG7-100B

Application
2016 PILOT

Publications No.
VERSION 1
Issue Date
JUN 2015

PARTS LIST

Rear lower trim



9 Clips A



7 Clips B



TOOLS AND SUPPLIES REQUIRED

- Ratchet
- 10 mm and 19 mm Sockets
- Phillips screwdriver
- Drill
- 3 mm, 6 mm, 8 mm, and 10 mm Drill bits
- Eye protection (face shield, safety goggles, etc.)
- File
- Pushpin
- Diagonal cutters
- 10 mm Open end wrench

The following tool is available through the Honda Tool and Equipment Program. On the iN, click on: Service > Service Bay > Tool and Equipment Program, then enter the number under "Search". Or, call 888-424-6857.

- Plastic Trim Tool (T/N SILTRIMTL10)

Illustration of the Rear Lower Trim on the Vehicle

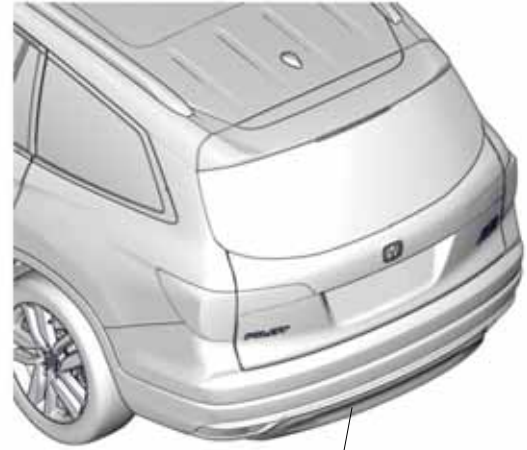

**REAR LOWER
TRIM**

QDD0401AA

INSTALLATION

Customer Information: The information in this installation instruction is intended for use only by skilled technicians who have the proper tools, equipment, and training to correctly and safely add equipment to your vehicle. These procedures should not be attempted by "do-it-yourselfers."

NOTE:

- Do not damage the body paint finish.
- Clean and wax the areas to be covered with a high quality paste wax.

1. Disconnect the negative cable:
 - Wrap a shop towel around the hood latch.

HOOD LATCH
(Wrap with a shop towel.)

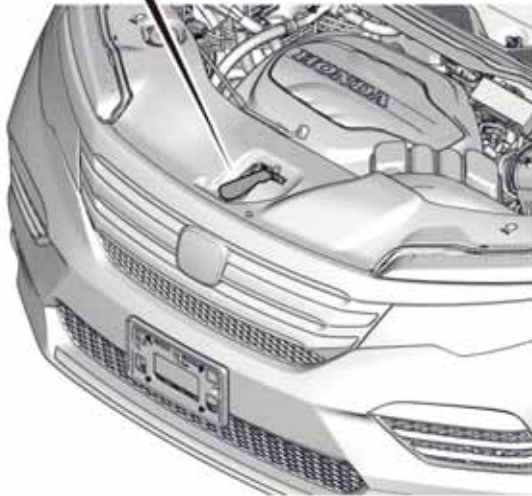
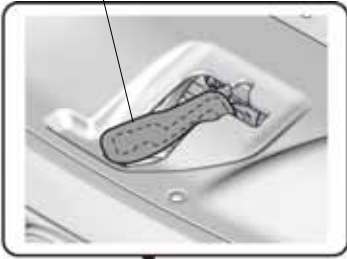

QDN1301AA

- Remove the front bulkhead cover.

FRONT BULKHEAD COVER

10 CLIPS

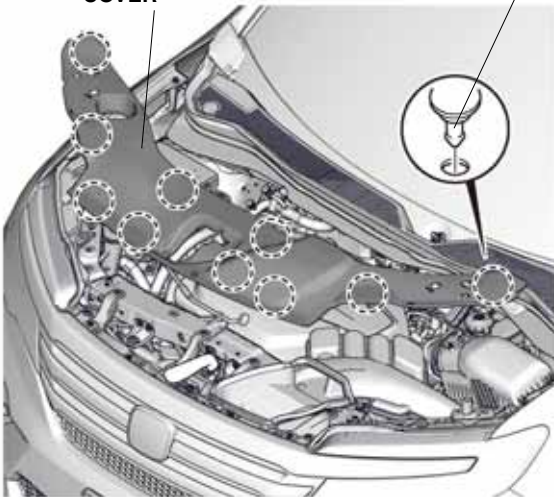

QDN1302AA

- Remove the intake air tube.
- Disconnect the negative cable.

2 CLIPS

INTAKE AIR TUBE

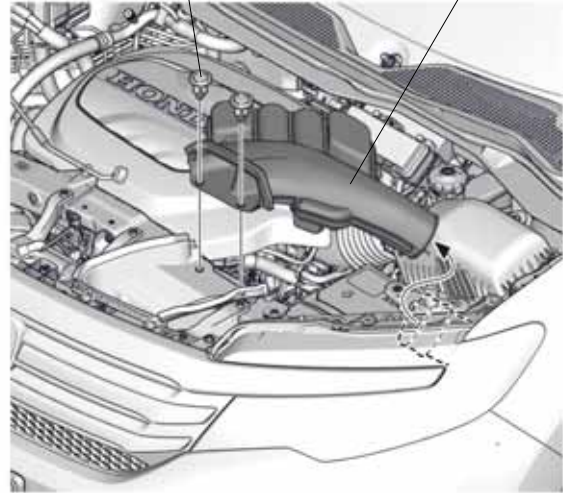

QDN1303AA

2. Remove the cargo lid.

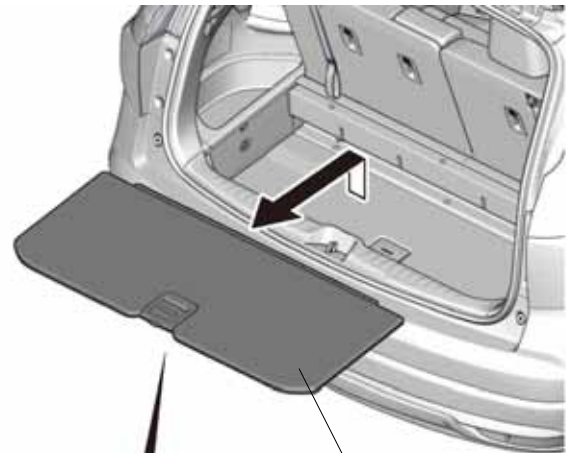

CARGO LID

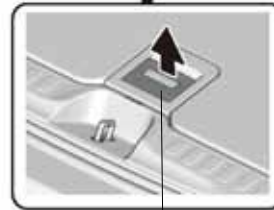

LEVER

QDN1009AC

3. Remove the spare tire plug cap.

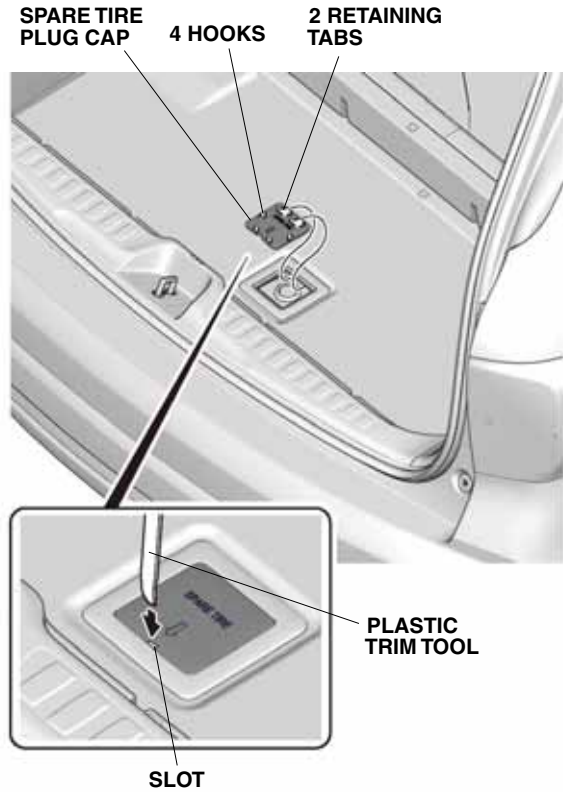

4. Remove the spare tire plug to access the spare tire hoist shaft. Lower the spare tire completely.



5. Remove the left rear fog light and unplug the vehicle connector.

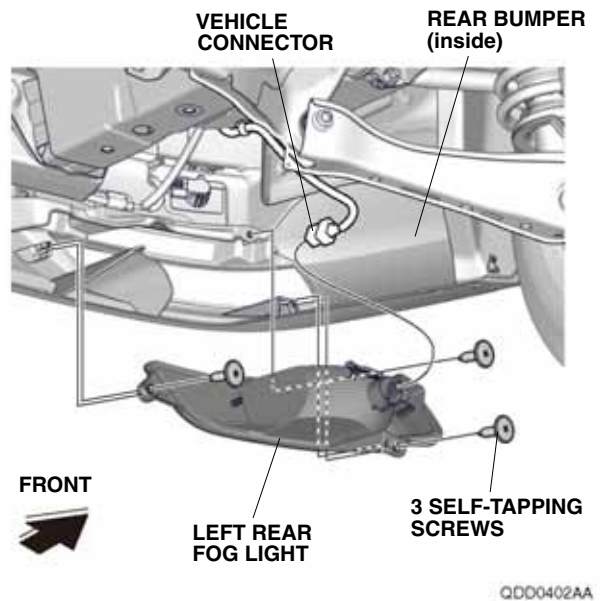

6. Repeat step 5 to remove the right rear fog light.

7. Using a pushpin, pierce the sixteen scribe marks on the rear bumper.

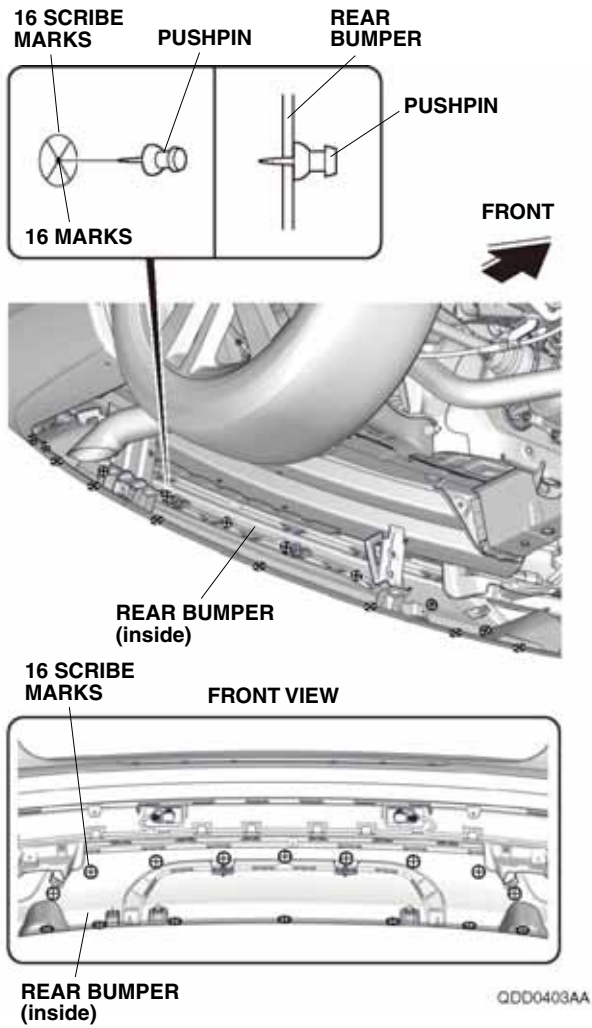

8. While wearing eye protection, drill the nine upper pierced marks.
- NOTE: Make sure to drill perpendicular to the rear bumper.
- First drill with a 3 mm drill bit, next drill with a 6 mm drill bit and an 8 mm drill bit, and finish with a 10 mm drill bit. Remove any burrs.

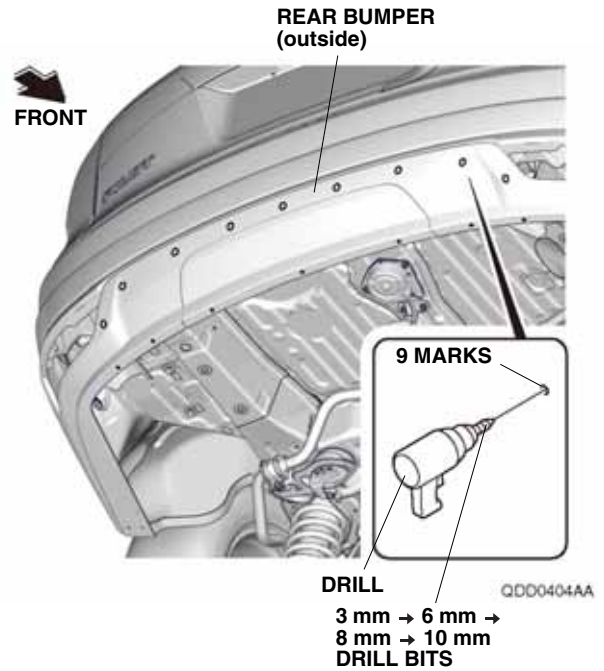

9. While wearing eye protection, drill the seven lower pierced marks.
- NOTE: Make sure to drill perpendicular to the rear bumper and do not damage the inner housing.
- First drill with a 3 mm drill bit, next drill with a 6 mm drill bit and an 8 mm drill bit, and finish with a 10 mm drill bit. Remove any burrs.

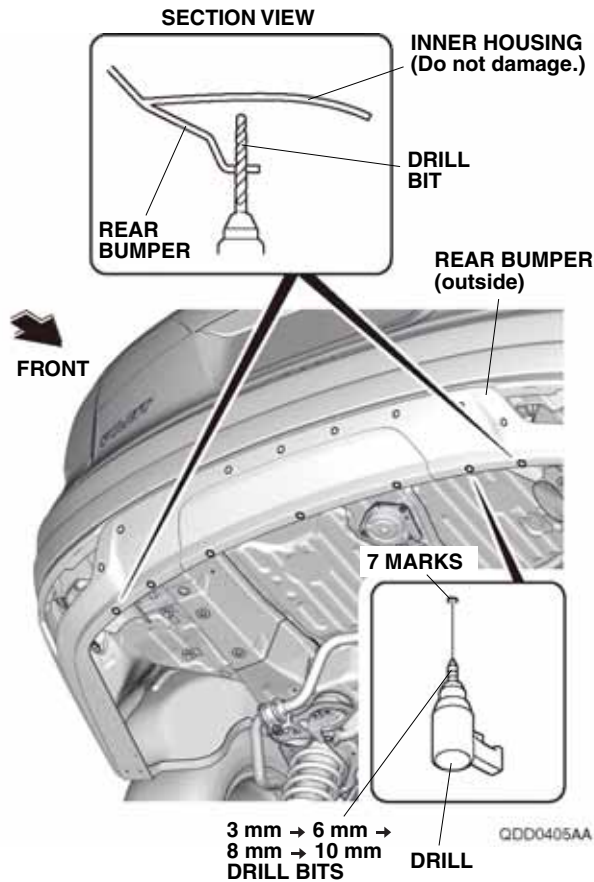

10. Install the rear lower trim to the rear bumper.

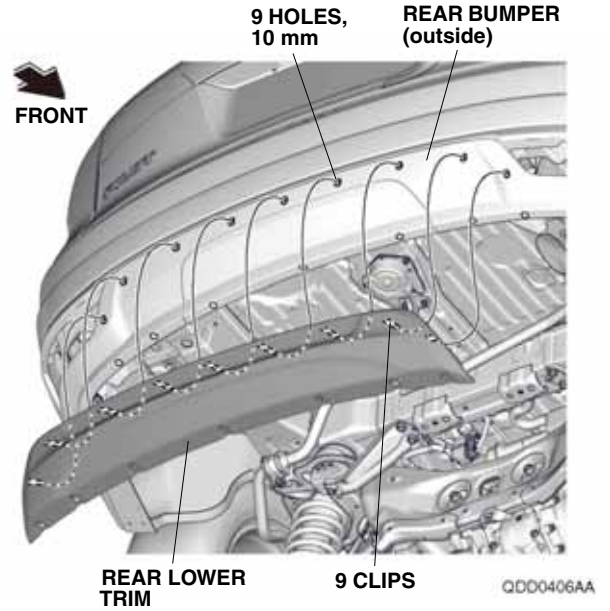

11. Secure the rear lower trim with nine clips A.
- NOTE: Do not push the clip too tightly, or it may deform the rear lower trim. Readjust the clip, if necessary.

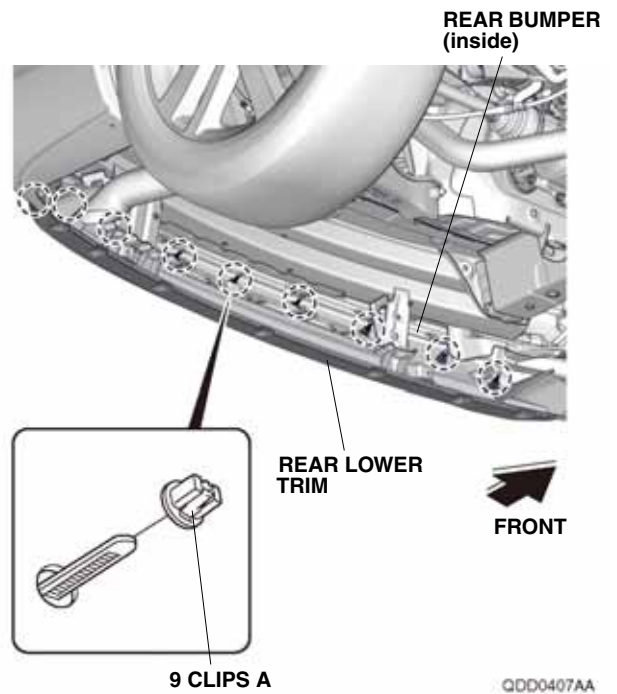

12. Secure the rear lower trim with seven clips B.

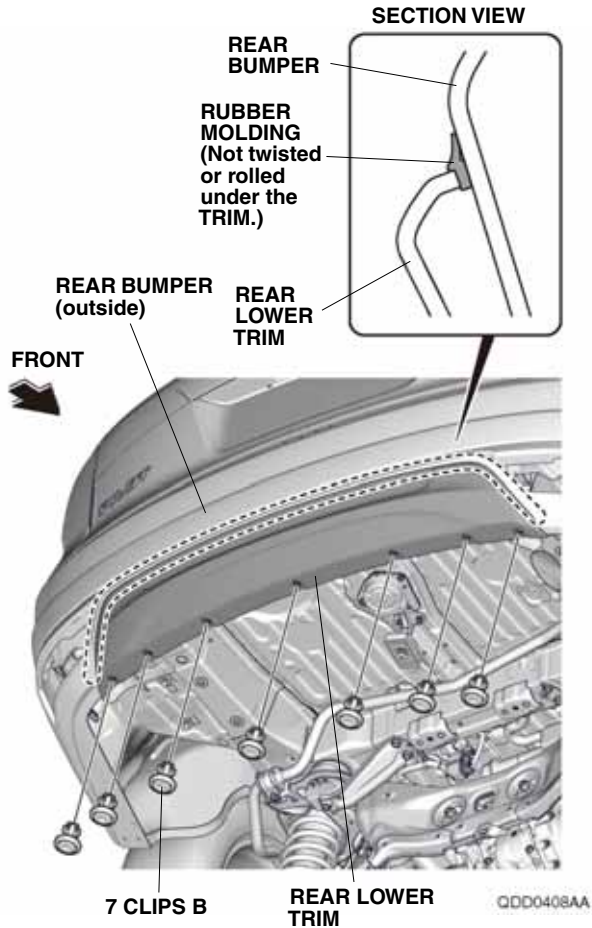

13. Cut off the excess from the two clips A at the rear fog lights area.

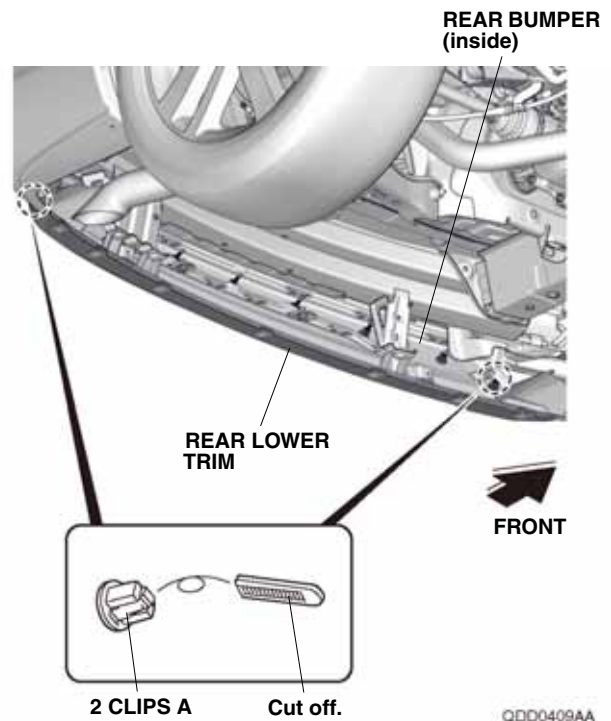

14. Reinstall all removed parts except for the front bulkhead cover and the intake air tube.
15. Check that all wire harnesses are routed properly and all connectors are plugged in.
16. Reconnect the negative cable to the battery.
17. Reinstall the front bulkhead cover and the intake air tube.
18. Press and hold the audio power button for two seconds to restore the audio and navi (if equipped) system functions.
19. Reset the clock on vehicle without navigation.
20. Restore the systems back to normal operation as described in the Service Manual if necessary.