



INSTALLATION INSTRUCTIONS

Accessory
FOG LIGHTS
 P/N 08V31-SZA-100C

Application
2012 PILOT
 (LX ONLY)

Publications No.
All 46379

Issue Date
AUG 2011

PARTS LIST

2 Fog lights

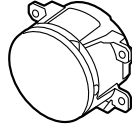

Headlight switch

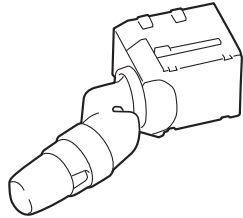

Fog light harness

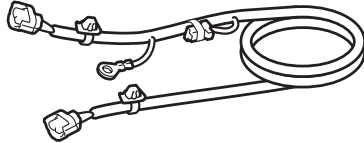

Left cover

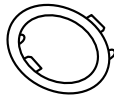

Right cover

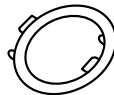

11 Wire ties

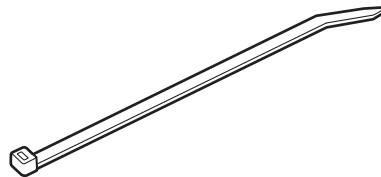

4 Self-tapping screws



Ground bolt

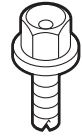

Relay

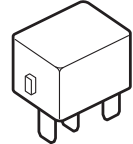

TOOLS AND SUPPLIES REQUIRED

- Phillips screwdriver
- Stubby Phillips screwdriver
- Ratchet
- 10 mm Socket
- 10 mm Open end wrench
- Diagonal cutters
- Blanket

The following tool is available through the Honda Tool and Equipment Program. On the iN, click on: Service > Service Bay > Tool and Equipment Program, then enter the number under "Search". Or, call 888-424-6857.

- Trim tool set (T/N SOJATP2014)

Illustration of the Fog Lights Installed on the Vehicle

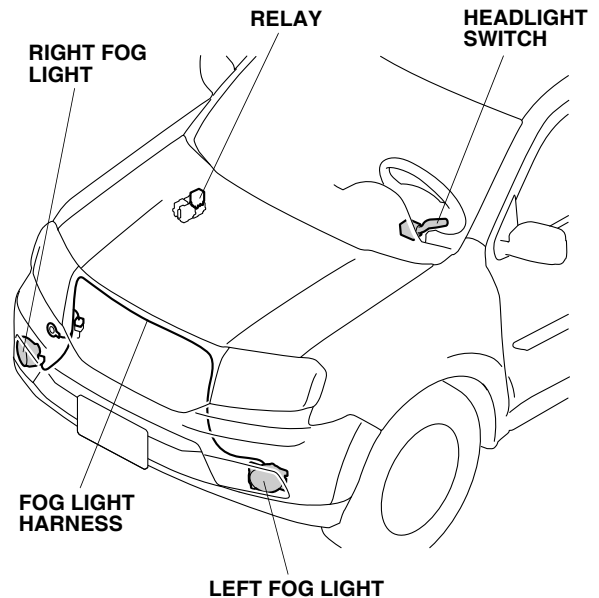

INSTALLATION

Customer Information: The information in this installation instruction is intended for use only by skilled technicians who have the proper tools, equipment, and training to correctly and safely add equipment to your vehicle. These procedures should not be attempted by “do-it-yourselfers.”

1. Make sure you have the anti-theft code for the radio, then write down the radio station presets.
2. Disconnect the negative cable from the battery.
3. Open the hood, and remove the intake air box (two clips).

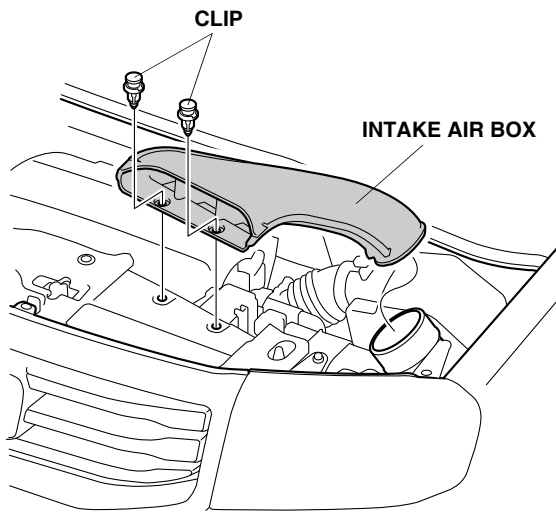

4. Remove the front bulkhead cover (seven clips).

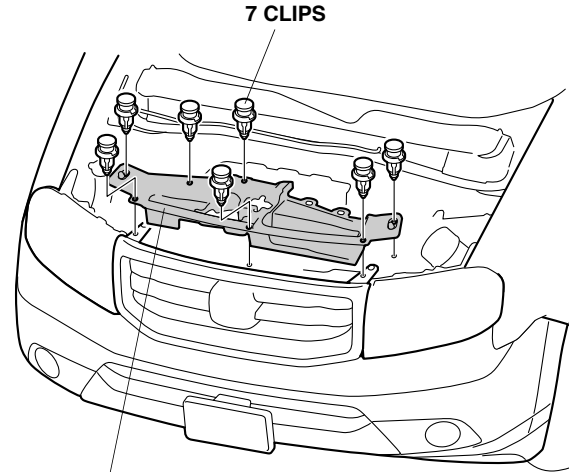

FRONT BULKHEAD COVER

5. With the help of an assistant, remove the front bumper (eight clips, three long clips, four self-tapping screws, two long self-tapping screws, four bolts and two bolts). Place the front bumper on a blanket after removal.

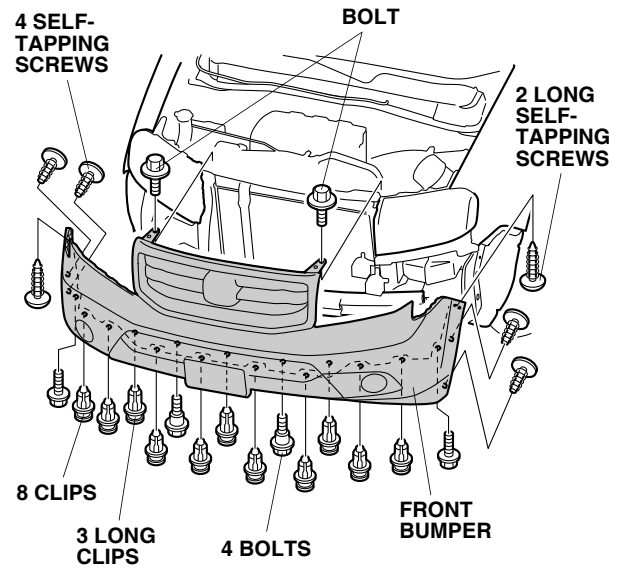

6. Remove the bezel cover from the left fog light bezel (four retaining tabs).

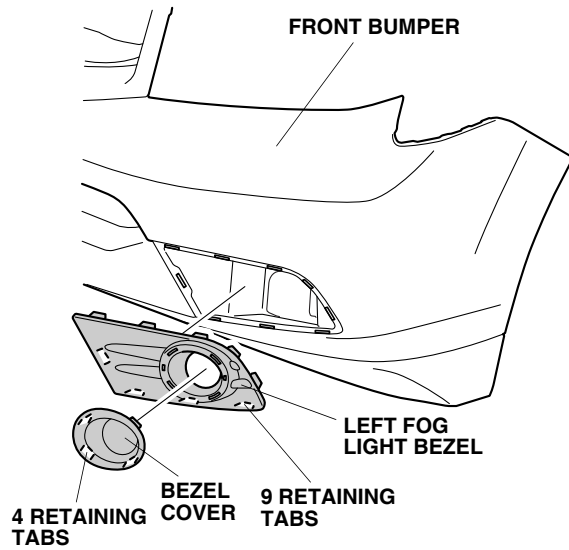

7. Remove the left fog light bezel from the front bumper (nine retaining tabs).
8. Repeat steps 6 through 7 on the right side of the front bumper.

Installing the Fog Lights

9. Install the fog light to the front bumper using two self-tapping screws.

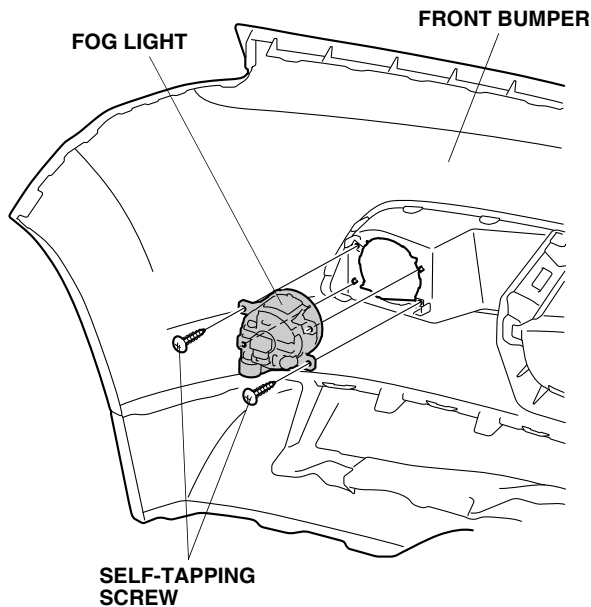

10. Reinstall the left fog light bezel to the front bumper.

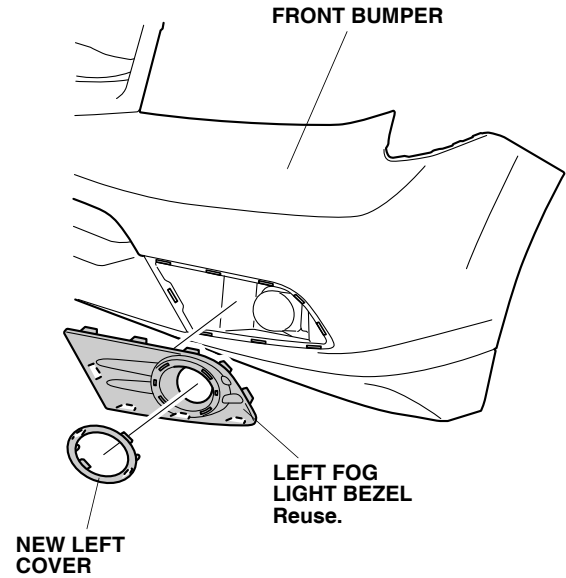

11. Install the new left cover to the left fog light bezel.
12. Repeat steps 9 through 11 to install the right fog light assembly to the right side of the front bumper.

Routing the Fog Light Harness

13. Under the radiator reservoir, locate the vehicle 1-pin connector blue-taped to the vehicle harness. Remove the blue tape to free the connector.

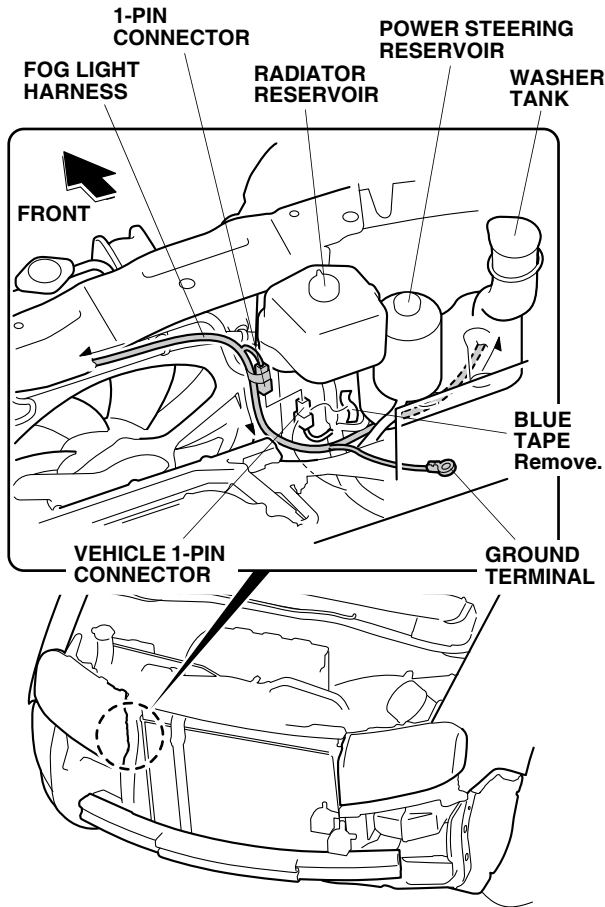

14. Get the fog light harness. Plug the fog light harness 1-pin connector into the vehicle 1-pin connector you just freed.
15. Route the ground terminal from the fog light harness down under the washer tank.

16. Route the fog light harness forward, and secure the fog light harness ground terminal to the vehicle frame with the ground bolt supplied.

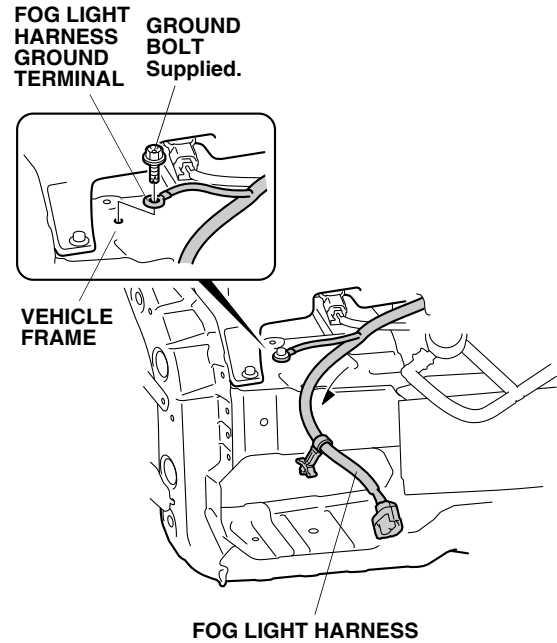

17. Secure the clip on the fog light harness to the vehicle panel hole.

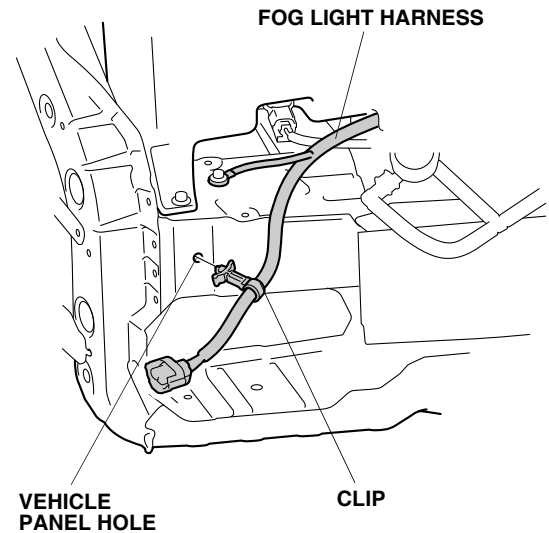

18. Route the other end of the fog light harness 2-pin connector up along the vehicle harness.

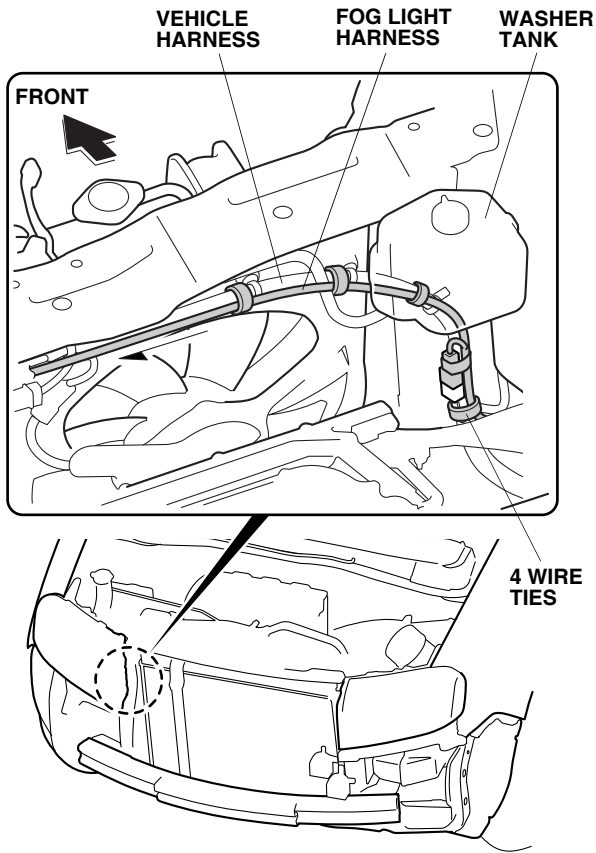

19. Secure the fog light harness to the vehicle harness using four wire ties.

20. Route the fog light harness 2-pin connector over the fan shroud, and along the vehicle harness to toward the left side of the vehicle.

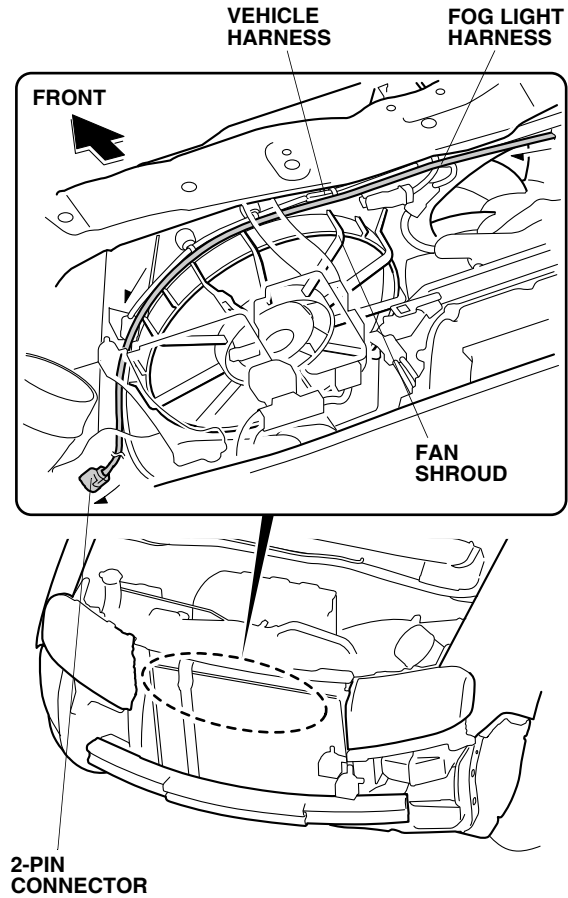

21. Continue to route the fog light harness 2-pin connector down and through the front bulkhead.

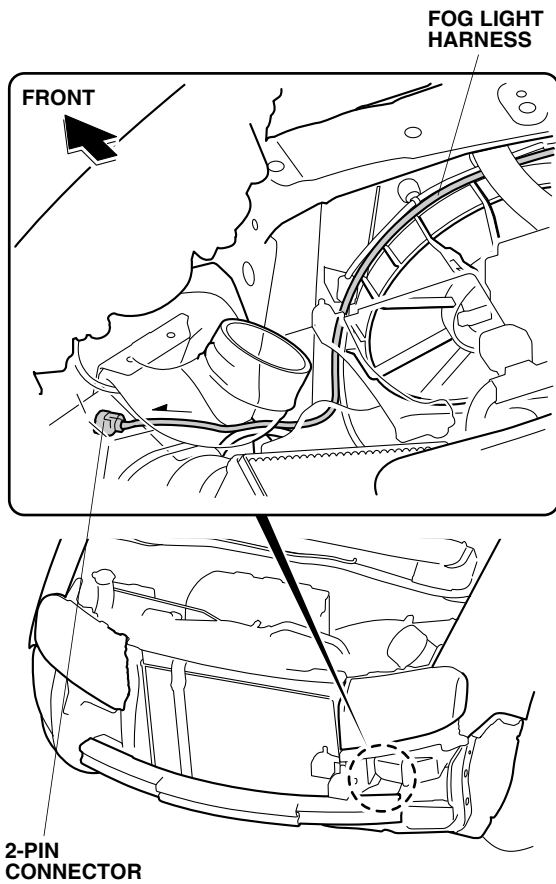

24. Secure the fog light harness to the vehicle harness using one wire tie in the area shown.

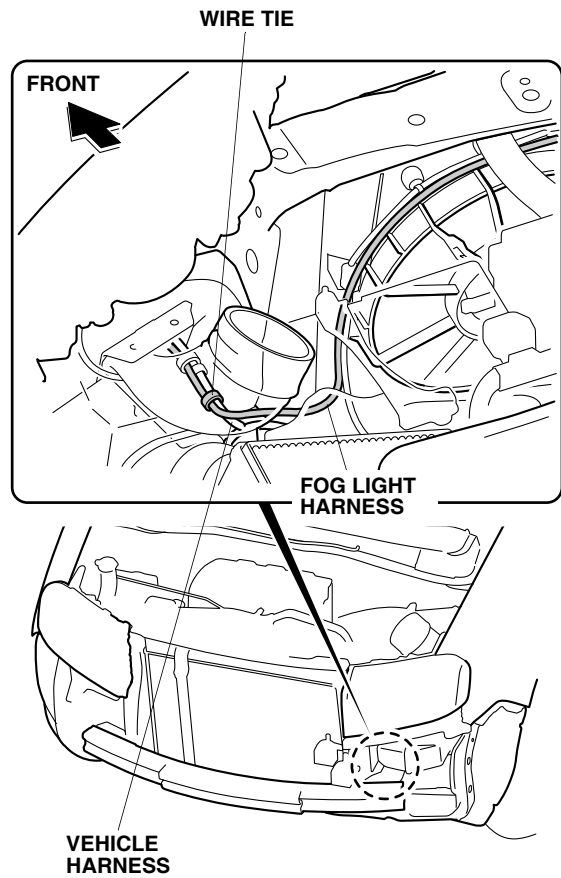

22. Secure the clip on the fog light harness to the vehicle panel hole.

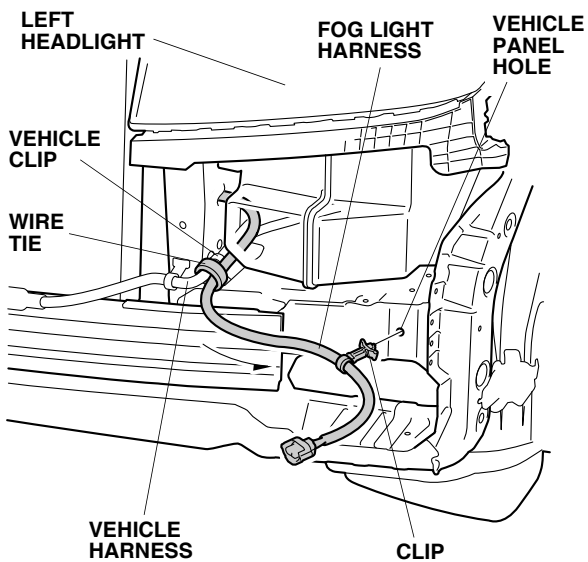

23. Secure the fog light harness to the vehicle harness using one wire tie.

25. Secure the fog light harness to the vehicle harness using five wire ties in the areas shown.

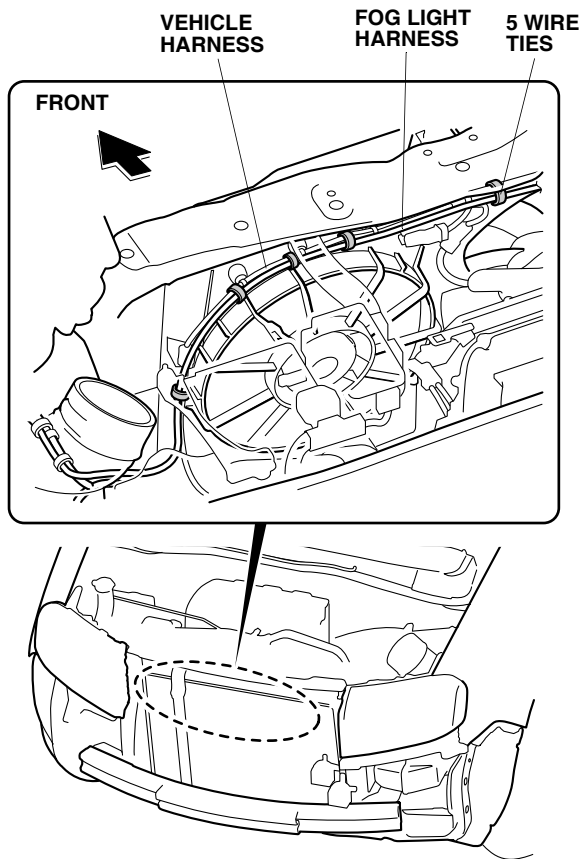

26. With the help of an assistant, bring the front bumper to the vehicle, and plug two fog light harness 2-pin connectors to two fog lights. Reinstall the front bumper.

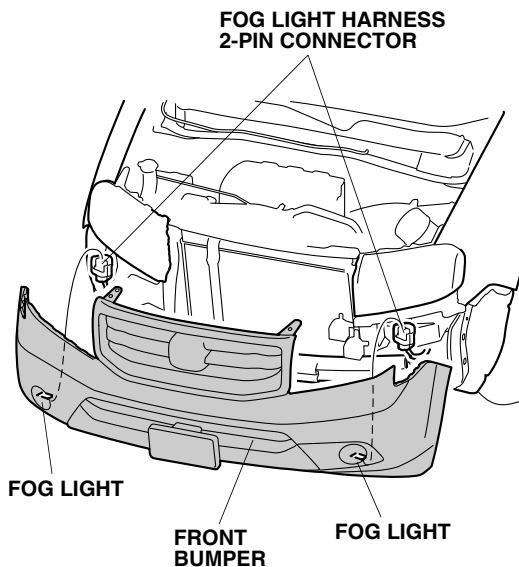

Installing the Headlight Switch

27. Inside the vehicle, lower the tilt lever and pull the steering wheel out.

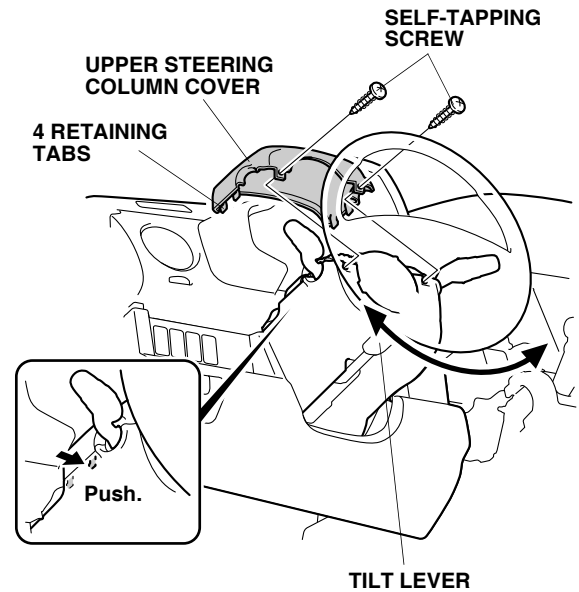

28. Remove the upper steering column cover:
- Remove two self-tapping screws.
 - Push the upper cover in at the areas shown to release the four retaining tabs.
29. Remove the lower steering column cover (two self-tapping screws and one screw).

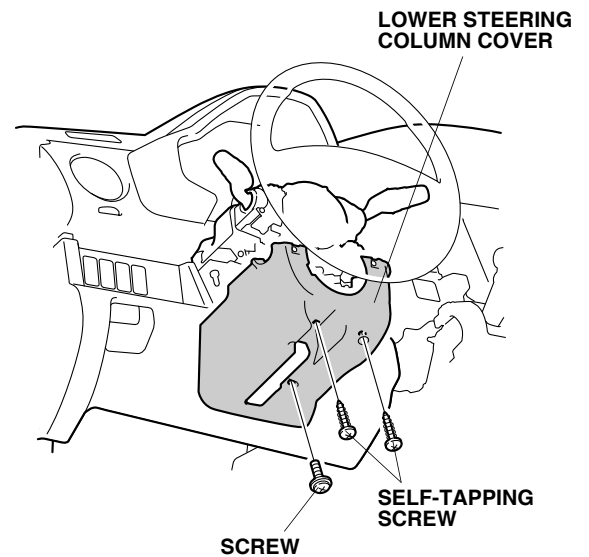

30. Turn the steering wheel 90° counterclockwise, and unplug the vehicle connector from the headlight switch.

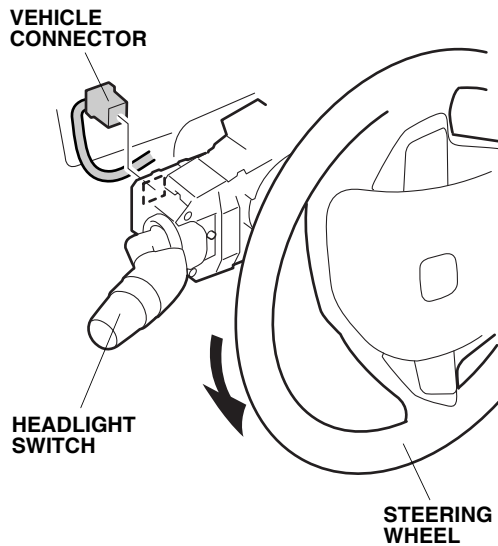

31. Remove two self-tapping screws from the headlight switch. While pushing the retaining tab, slide the headlight switch, and remove it from the steering column.
NOTE: Do not pull on the lever when removing the switch.

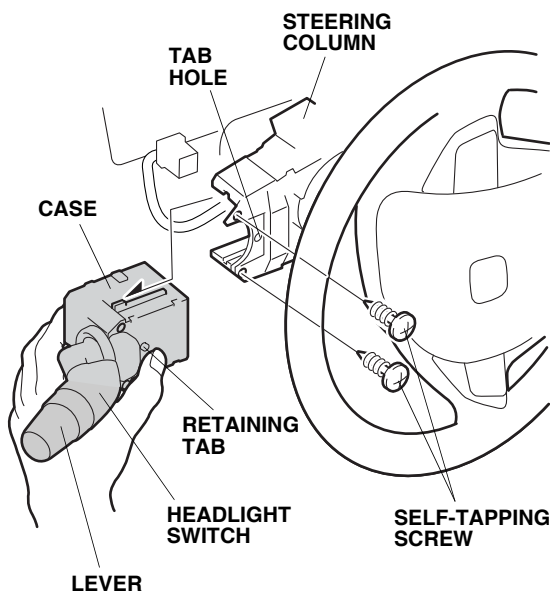

32. Install the new headlight switch to the steering column using two self-tapping screws. Hold the case by hand, then install the new headlight switch to the steering column.
NOTE: Do not push on the lever when installing the case.

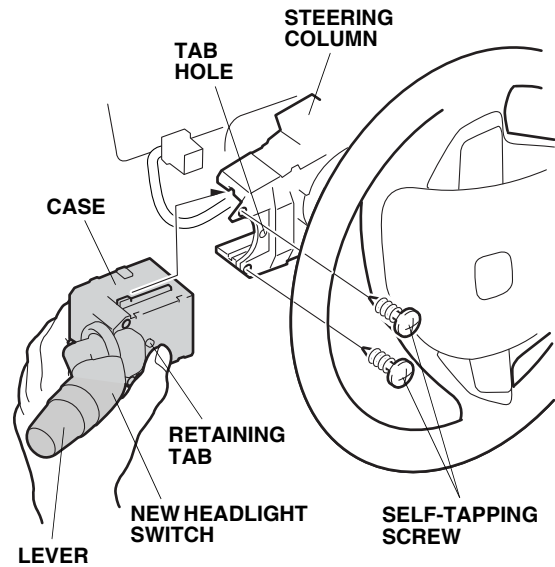

33. Plug the vehicle connector into the new headlight switch.

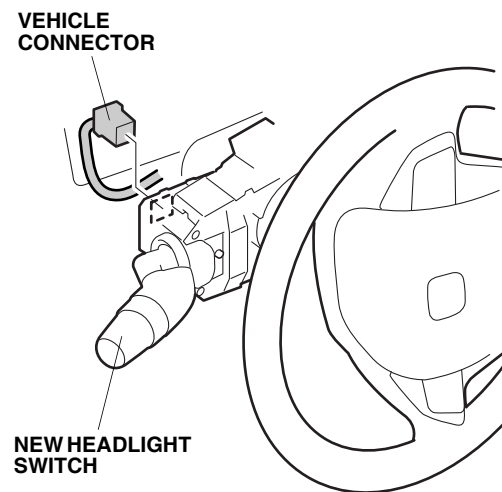

Installing the Relay

34. Remove the right front side step trim (four clips).

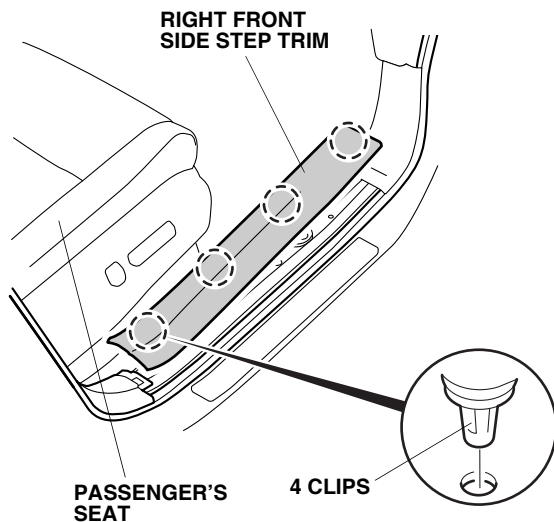

35. Pull away the door opening seal, and remove the right kick panel (two clips).

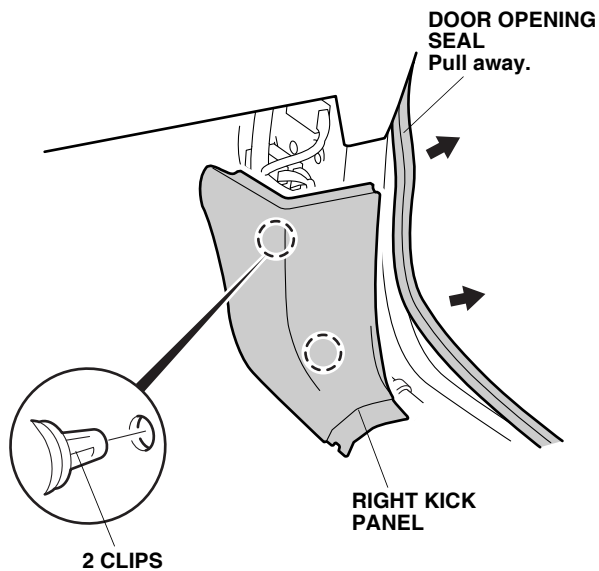

36. Install the relay into the vehicle relay block.

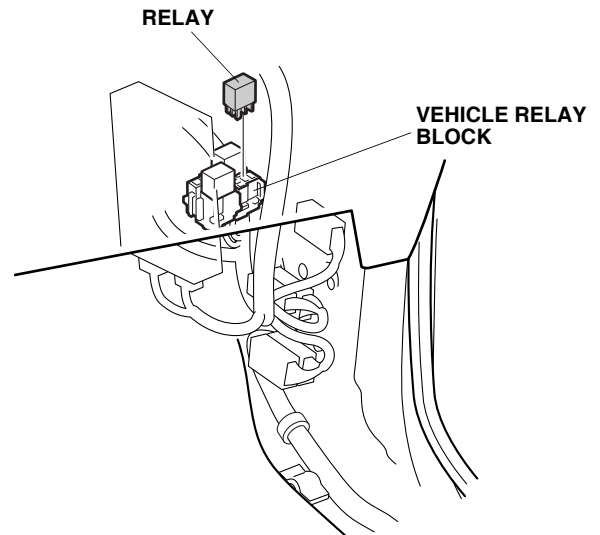

37. Check that all wire harness and cables are routed properly and that all connectors are plugged in.
38. Reinstall all removed parts.
39. Reconnect the negative cable to the battery.
40. Enter the anti-theft code for the audio unit and navigation system if equipped and reset the radio station presets.
41. Reset the clock on vehicles without navigation.

Use and Care

How to Operate the Fog Lights

- Turn the headlight switch to the “D” position (headlights on low beam).
- Turn the fog light switch on (indicator is on).
- If the fog lights do not turn on, check the fuse and all the connectors, including the ground cable.

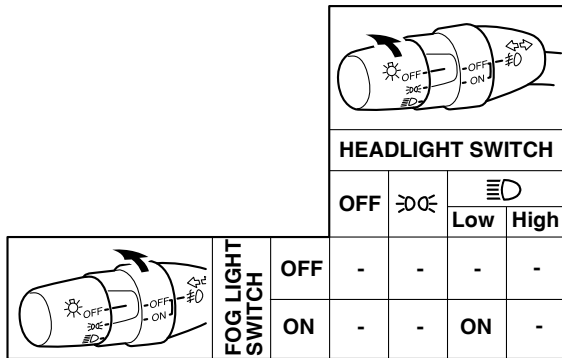

NOTE: The fog light lenses can cloud when the outside temperature is cold; this is normal and should go away in warm weather.

Fog Light Aiming Adjustment

42. Release the left front inner fender (one long self-tapping screw, two self-tapping screws and one bolt).

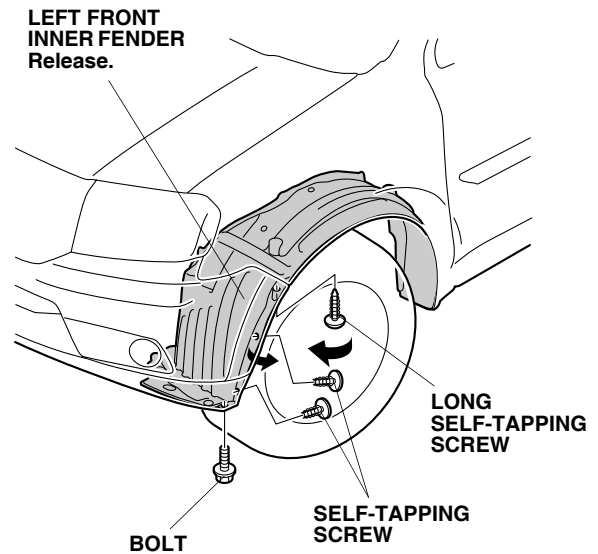

43. Adjust the fog light:
 - Adjust the aiming according to local laws and regulations.
 - To adjust, turn the aiming adjustment knob in or out until the correct aiming is obtained.

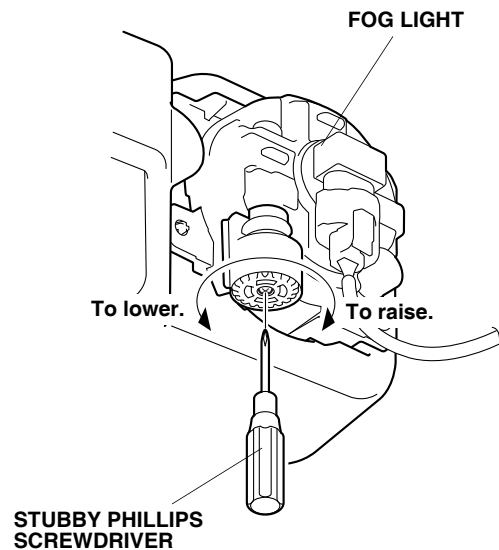

44. Reinstall the all removed parts.

BULB REPLACEMENT

1. Release the left front inner fender (one long self-tapping screw, two self-tapping screws and one bolt).

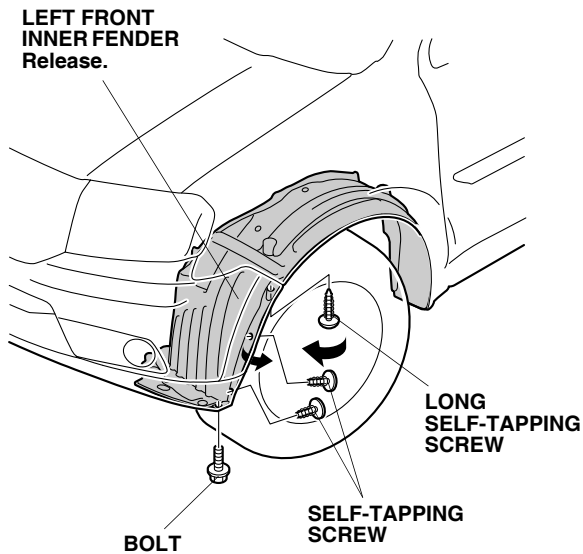

2. Insert your hand inside of the left front inner fender released in step 1. Unplug the connector from the fog light.

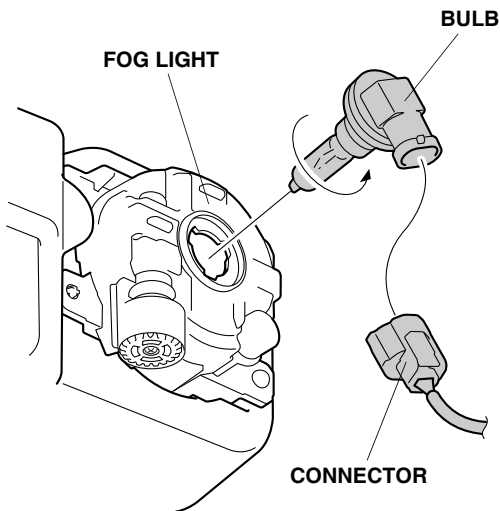

3. Remove the bulb.

4. Install the new bulb to the fog light.
 - Use only a Genuine Honda halogen light bulb of specified wattage.

Rating: 12V 55W H11 Halogen Light Bulb
P/N 33165-STK-A01

- Do not touch the bulb. Oily or greasy substances on the bulb can shorten its service life due to the heat produced when the bulb is turned on. If the bulb is accidentally touched, wipe it clean with a soft cloth that has been dampened with a denatured alcohol or a mild detergent solution.
- When installing the new bulb, align the cutout on the fog light with the tab on the new bulb and turn the new bulb in completely. If not properly aligned, the fog light may annoy oncoming driver's.

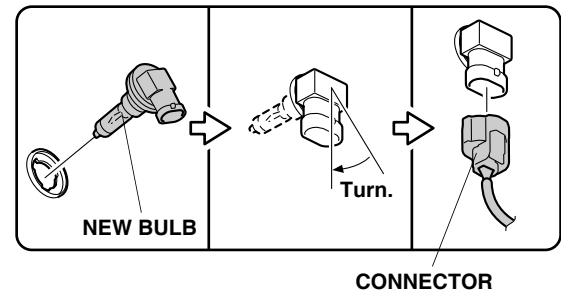
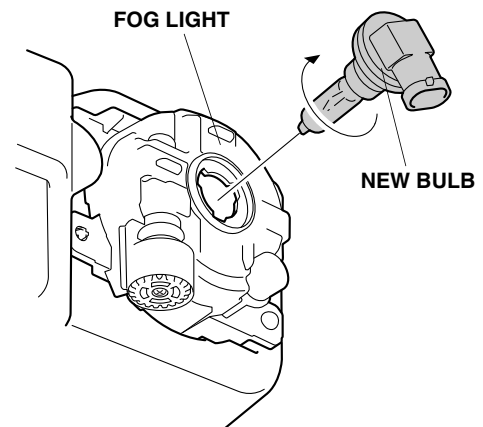

5. Reinstall the removed parts. Check that the wire harnesses are not pinched. Be sure to tighten the clip and bolts securely.
6. Check the operation of the fog light; adjust the aiming if necessary.