

Germain Honda of College Hills



INSTALLATION INSTRUCTIONS

Accessory

RUNNING BOARDS
P/N 08L33-TGS-100F

Application

2022 PASSPORT

Publications No.

VERSION 1

Issue Date

NOV 2021

PARTS LIST

Left running board



Right running board

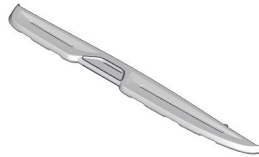

Left bracket A



Right bracket A



Left bracket B



Right bracket B



Left bracket C



Right bracket C



24 Flange bolts

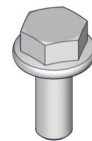

TOOLS AND SUPPLIES REQUIRED

Ratchet

File

13 mm Socket

Torque wrench

Utility knife

Touch-up paint

Illustration of the Running Boards on the Vehicle

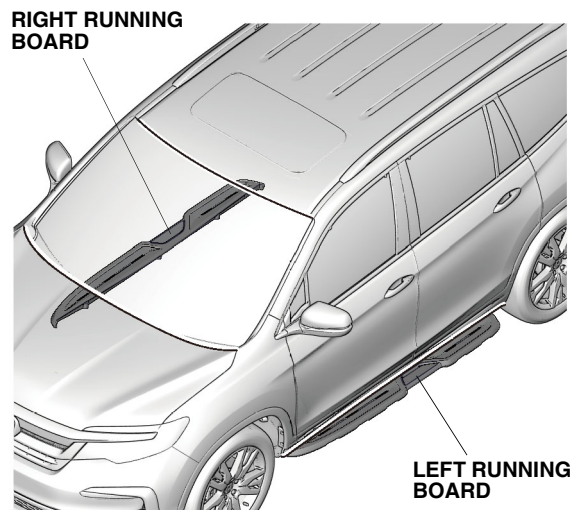

QH32201AN

Germain Honda of College Hills

INSTALLATION

Customer Information: The information in this installation instruction is intended for use only by skilled technicians who have the proper tools, equipment, and training to correctly and safely add equipment to your vehicle. These procedures should not be attempted by "do-it-yourselfers."

NOTE:

- Thoroughly clean the bottom of the body between the front and rear wheels.
 - Be careful not to damage the body paint finish.
1. Using a utility knife, cut out the left side sill panel as shown. Remove any burrs.

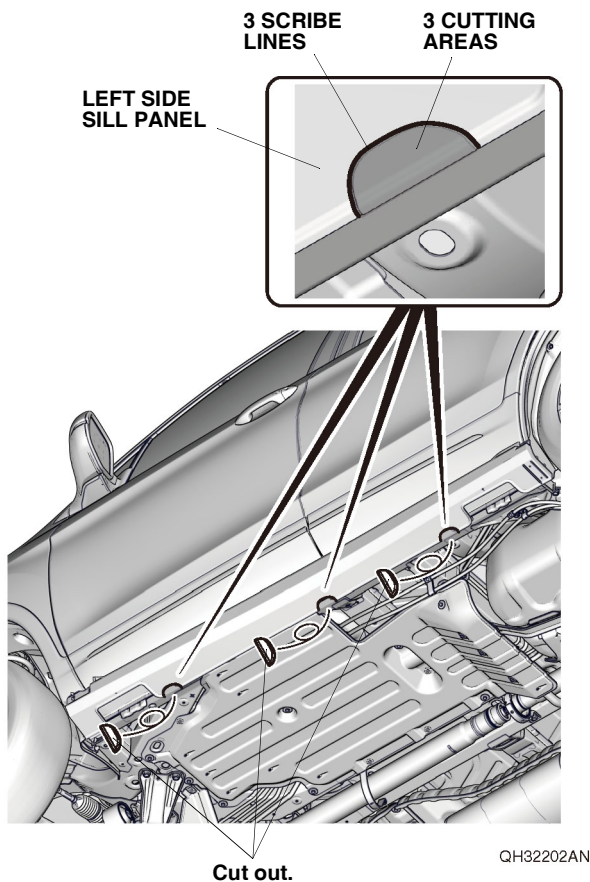

2. Remove the undercoating as shown. Apply touch-up paint where you removed the undercoating and allow it to dry thoroughly.

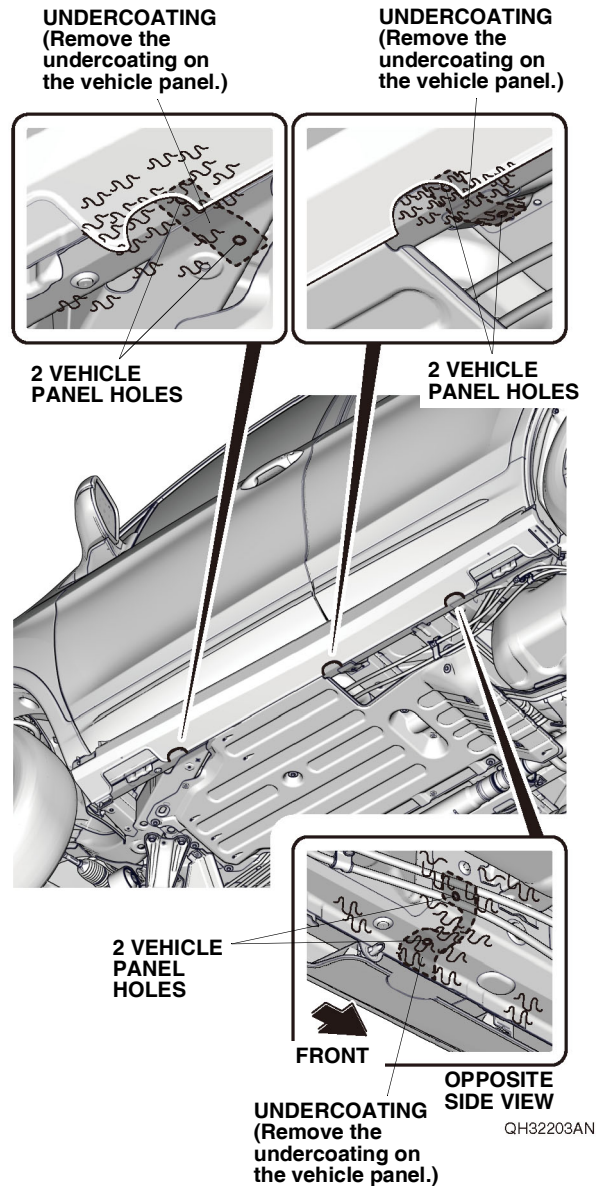

Germain Honda of College Hills

3. Loosely install the left bracket A, left bracket B, and left bracket C to the vehicle panel with six flange bolts.

NOTE: Make sure that the brackets are installed in the correct positions and orientations.

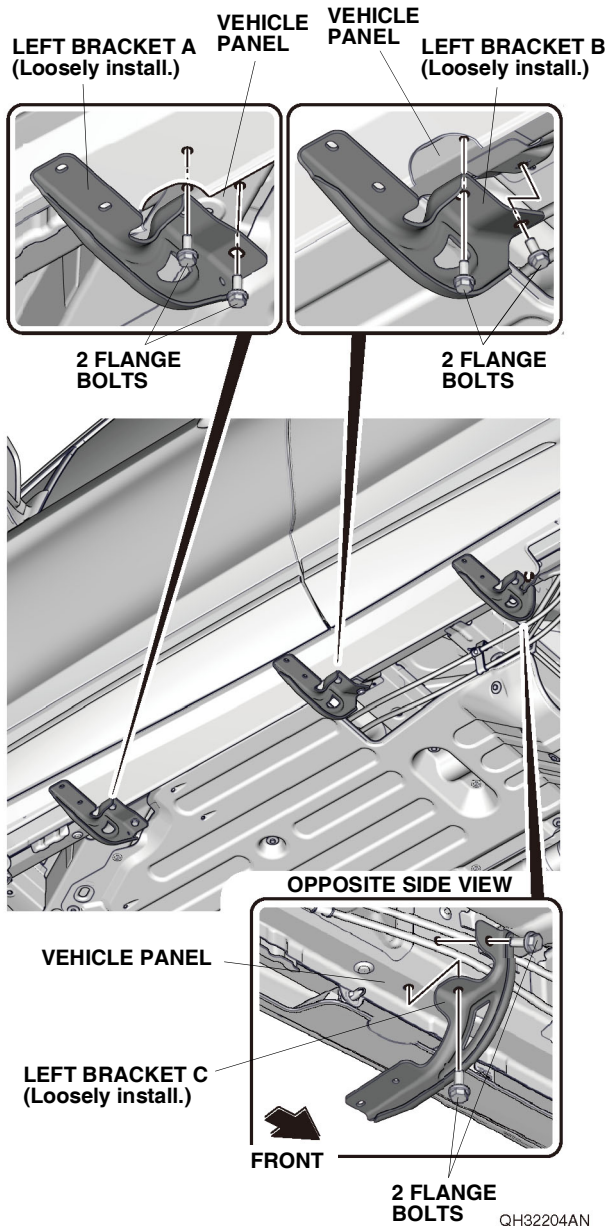

4. With the help of an assistant, install the left running board to the left bracket A, left bracket B, and left bracket C with six flange bolts. Torque the flange bolts to 20 lb-ft (27 N·m).

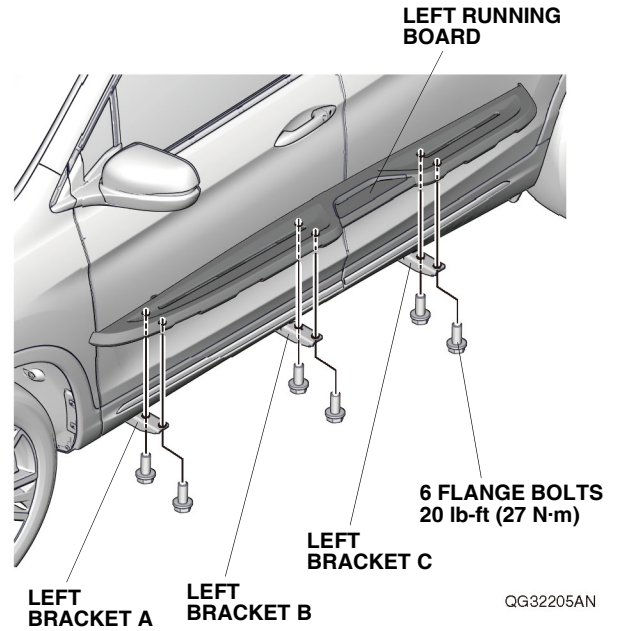

QG32205AN

Germain Honda of College Hills

5. Tighten the six flange bolts loosely installed in step 3. Torque the flange bolts to 20 lb-ft (27 N·m).

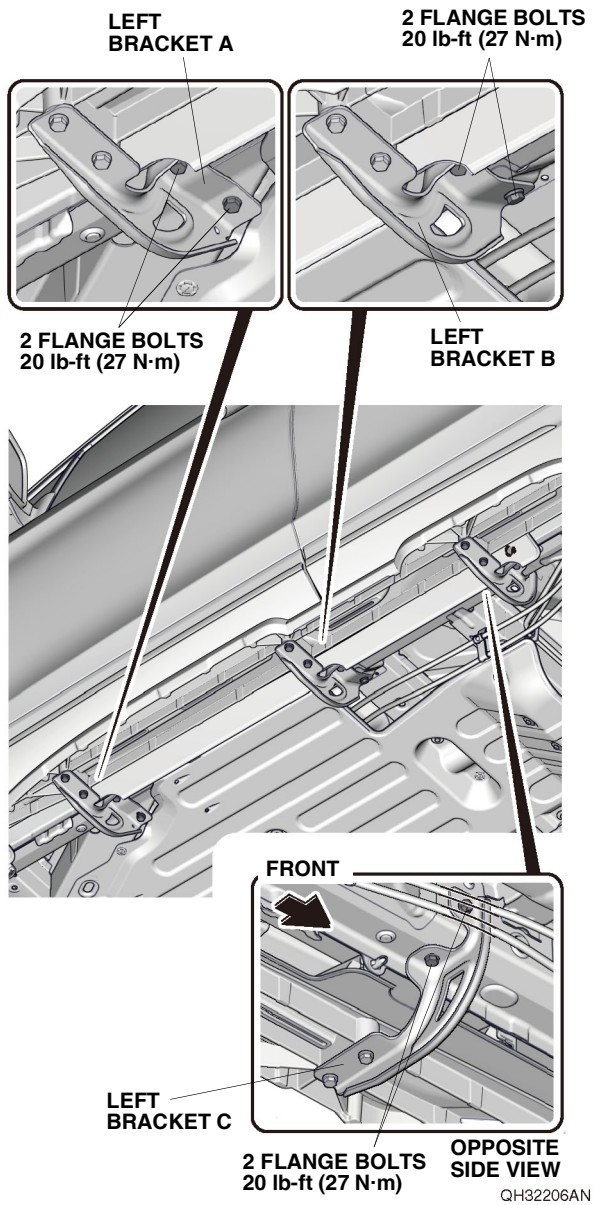

6. Repeat steps 1 through 5 on the right side of the vehicle.