



## INSTALLATION INSTRUCTIONS

Accessory  
**RUNNING BOARDS**  
 P/N 08L33-TGS-100D

Application  
**2019 PASSPORT**

Publications No.  
**VERSION 2**  
 Issue Date  
**MAY 2019**

### PARTS LIST

Left running board



Right running board



Left bracket A



Right bracket A



Left bracket C



Right bracket C



16 Flange bolts



### TOOLS AND SUPPLIES REQUIRED

- Ratchet
- File
- 13 mm Socket
- Torque wrench
- Utility knife
- Touch-up paint

### Illustration of the Running Boards on the Vehicle

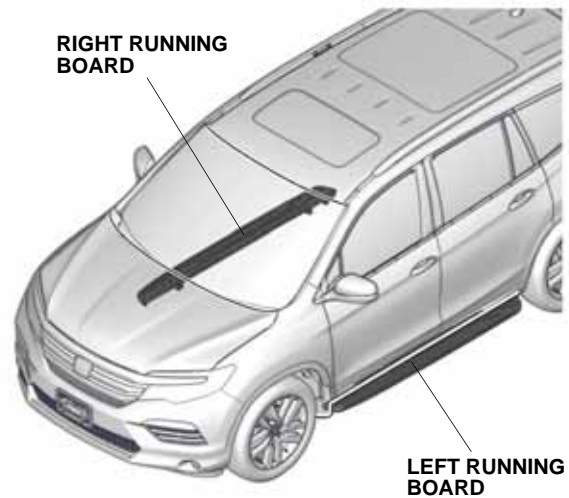

QDN1402BC

## INSTALLATION

**Customer Information:** The information in this installation instruction is intended for use only by skilled technicians who have the proper tools, equipment, and training to correctly and safely add equipment to your vehicle. These procedures should not be attempted by “do-it-yourselfers.”

### NOTE:

- Thoroughly clean the bottom of the body between the front and rear wheels.
  - Be careful not to damage the body paint finish.
  - These instructions show the left side running board being installed; the same procedure applies to installing the right running board.
1. Locate the two presets in the left side sill panel. Using an utility knife, cut out the left side sill panel along the each preset. Remove any burrs.

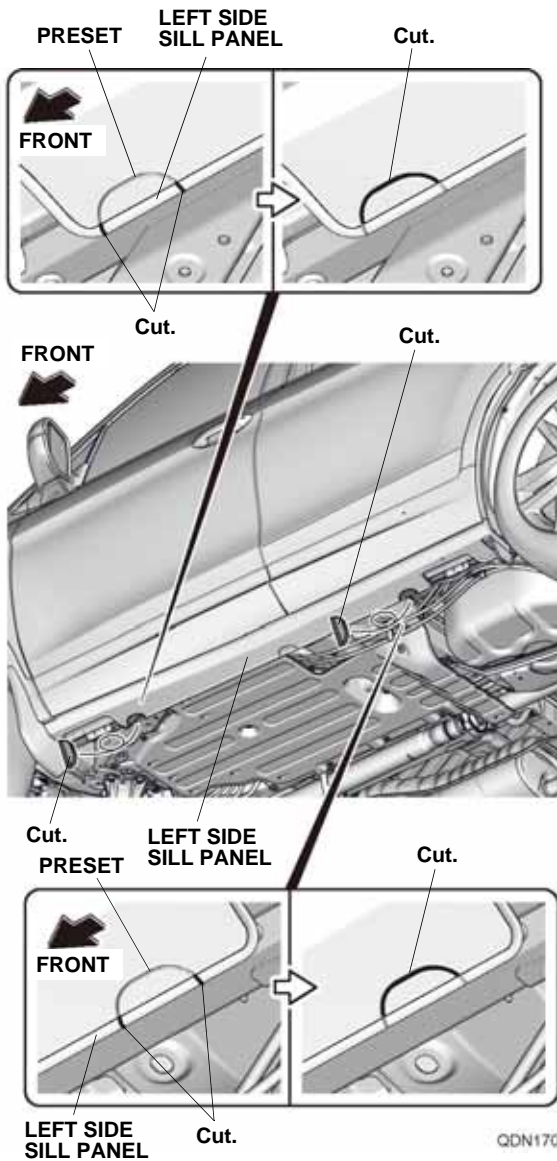

2. Remove the undercoating in the areas shown. Apply touch-up paint to the areas where you removed the undercoating, and allow them to dry thoroughly.

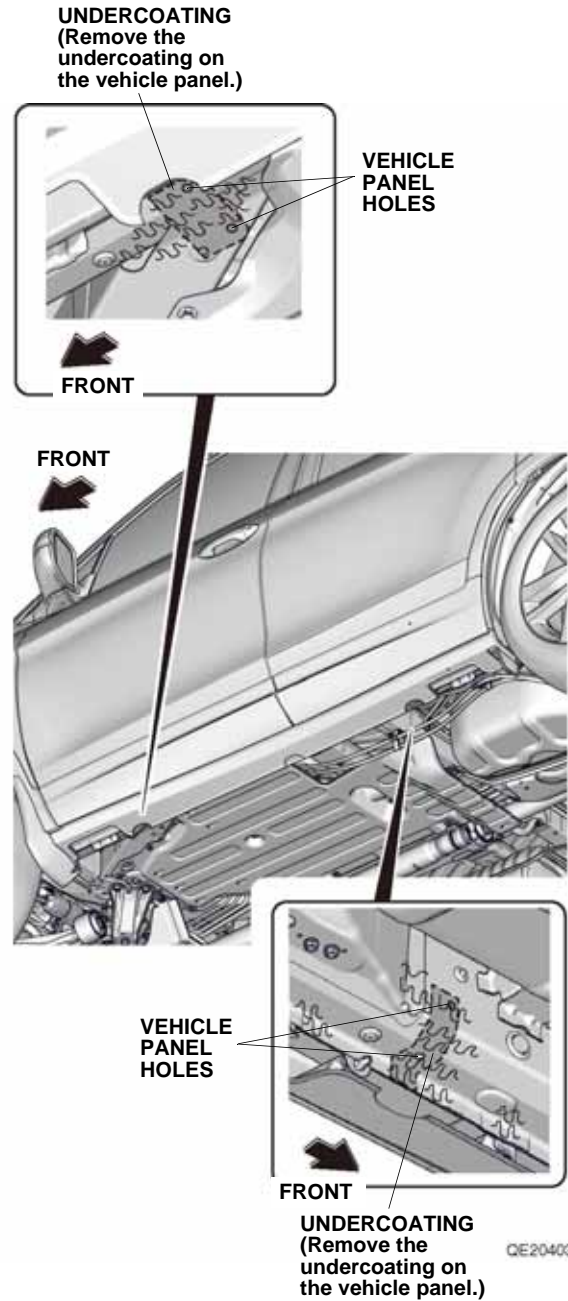

3. Loosely secure the left bracket A and left bracket C to the vehicle panel with four flange bolts.

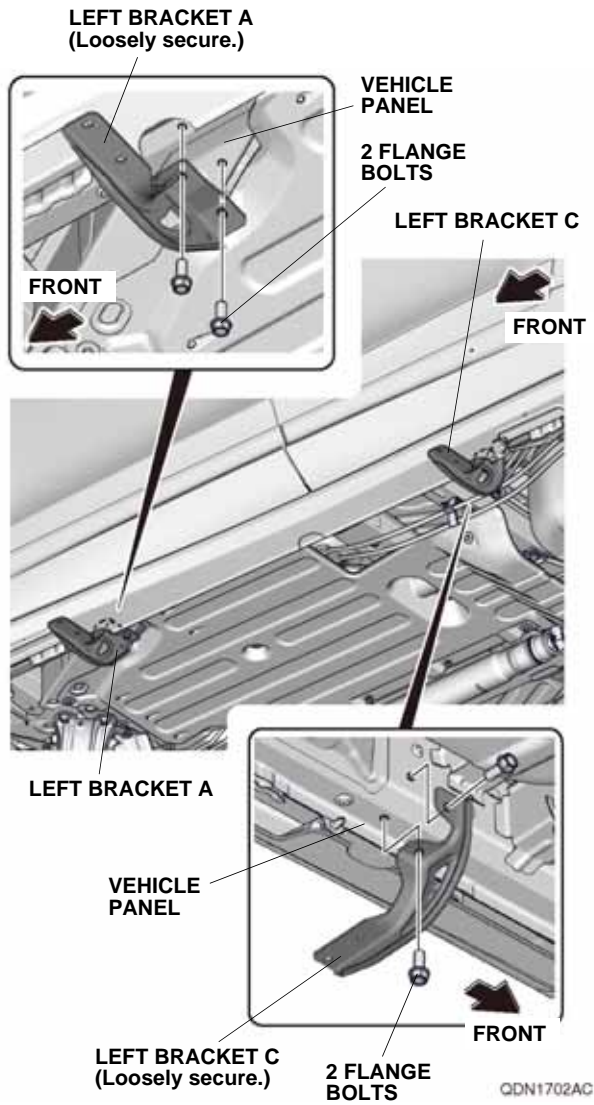

4. Secure the left running board to the left bracket A and left bracket C with four flange bolts. Torque the flange bolts to 20 lb-ft (27 N·m).

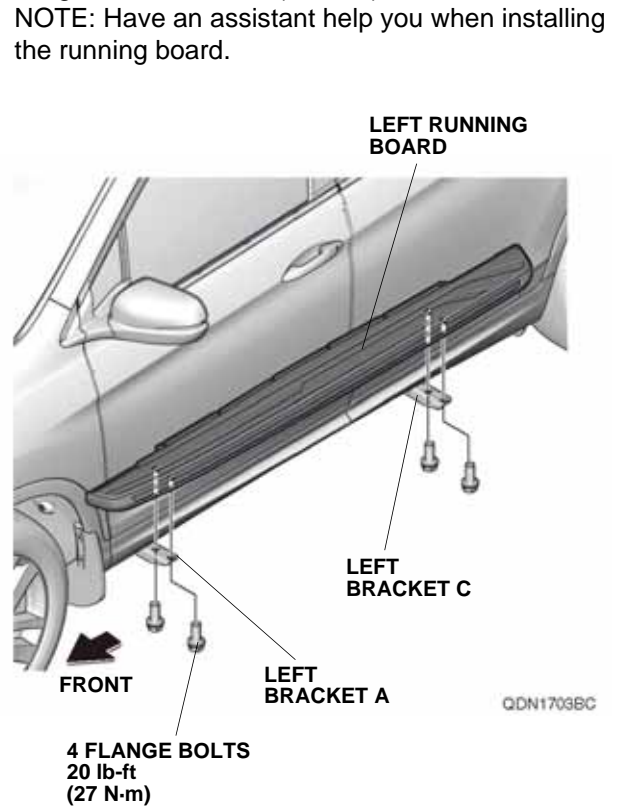

5. Tighten the four flange bolts loosely installed in step 3.  
3. Torque the flange bolts to 20 lb-ft (27 N-m).

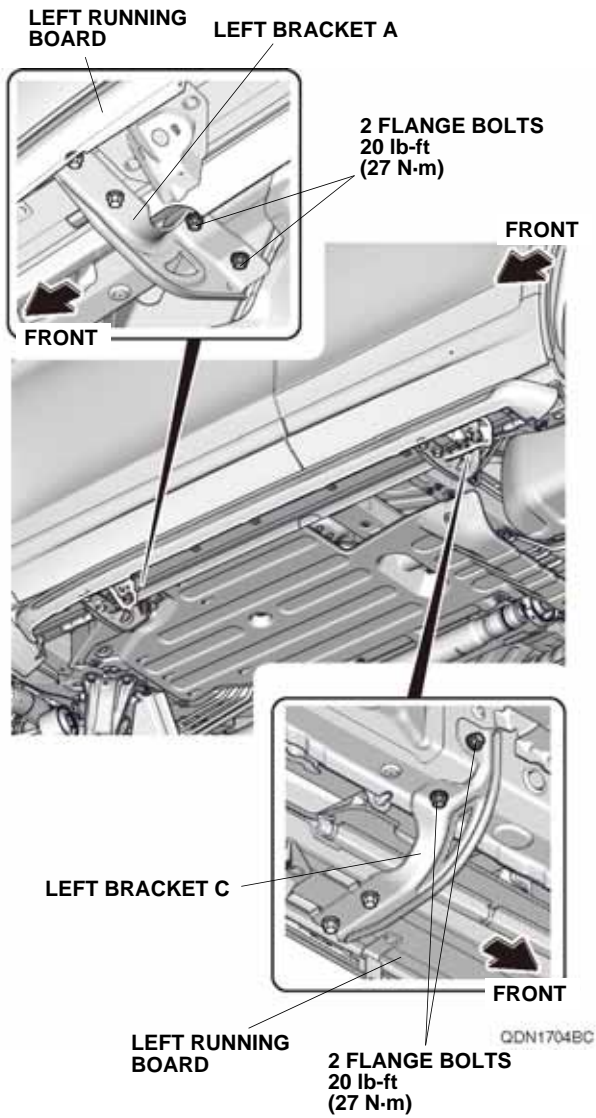

6. Repeat steps 1 through 5 on the right side of the vehicle to install the right running board.