



INSTALLATION INSTRUCTIONS

Accessory 19" ALUMINUM WHEEL P/N 08W19-THR-101	Application 2021 ODYSSEY	Publications No. VERSION 1
		Issue Date JUL 2020

PARTS LIST

Aluminum wheel
(The illustration may differ from the actual wheel.)



Wheel center cap
(The illustration may differ from the actual center cap.)



Tire and loading information label A
(SEATING CAPACITY: TOTAL 8)
(May not be used)



HR19A

Tire and loading information label B
(SEATING CAPACITY: TOTAL 7)
(May not be used)



HR19B

Wheel cleaning information
(Make sure your customer receives this information.)

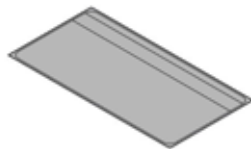

Parts for TPMS sensor assembly

Tire pressure sensor assembly



Washer



Valve nut



TOOLS AND SUPPLIES REQUIRED

- Ratchet
- 11 mm and 22 mm Sockets
- Torque wrench
- Isopropyl alcohol
- Shop towel
- i-HDS and DST-i

SPECIFICATIONS

Rim size	19 x 7 1/2J (inset 50)	
Tire size	235/55R19 101H	
Bolt hole PCD	120 (5 holes)	
Tire pressure	Front	36 psi (250 kPa)
	Rear	36 psi (250 kPa)

INSTALLATION

Customer Information: The information in this installation instruction is intended for use only by skilled technicians who have the proper tools, equipment, and training to correctly and safely add equipment to your vehicle. These procedures should not be attempted by “do-it-yourselfers.”

NOTE:

- This aluminum wheel is designed for use on a vehicle equipped with a TPMS (Tire Pressure Monitoring System).
- This aluminum wheel is equipped with a TPMS sensor. See the service information for the tire replacement and TPMS sensor installation procedures.
- The illustrations of the aluminum wheels are shown for reference purposes only.
- Install the correct size tire.
- Follow the instructions in the owner's manual when raising the vehicle, and when removing and installing the wheels. Do not overtighten the wheel nuts. Wheel nut torque: 127 N·m (94 lb·ft).
- Use a tire changer to install and remove the tires according to the directions in the operation manual furnished with the tire changer. Do not use a tire lever to install and remove the tires as it may cause damage to the tire and aluminum wheel.
- To allow the tire and loading information label adhesive to cure, do not wash the vehicle for 24 hours. Make sure your customer is aware of this.

1. Before installing the tire pressure sensor, clean the mating surface on the sensor and the aluminum wheel.

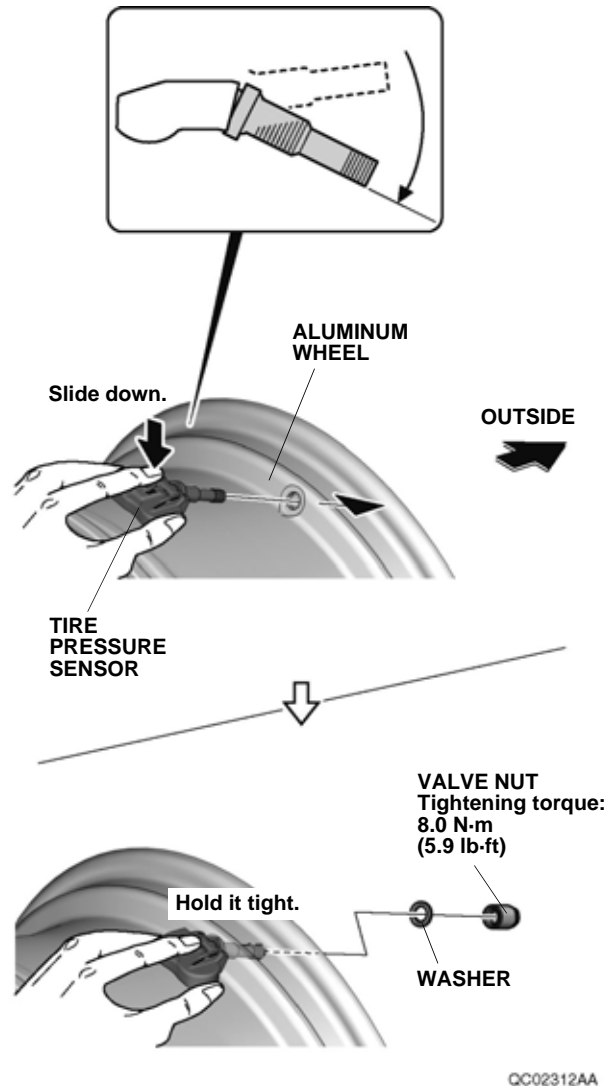

2. Install the tire pressure sensor and the washer on the aluminum wheel, and tighten the valve nut, finger tight. Make sure the tire pressure sensor is resting on the wheel.
3. While holding the tire pressure sensor against the wheel, tighten the valve nut to the specified torque. Tightening torque: 8.0 N·m (5.9 lb·ft)

NOTE:

- Check the grommet on the tire pressure sensor to make sure it is seated properly.
- Make sure the valve stem does not protrude into the sensor housing surface.
- To prevent the sensor housing from getting caught on the bead of the tire, install the tire pressure sensor so that the sensor housing does not protrude into the bead area of the wheel.
- Do not reuse a grommet that had been tightened, even one time, to the specified torque, as it is deformed inside.
- Do not use pneumatic or electric tools on the valve nut.
- Tightening the nut above the specified torque can damage the grommet.

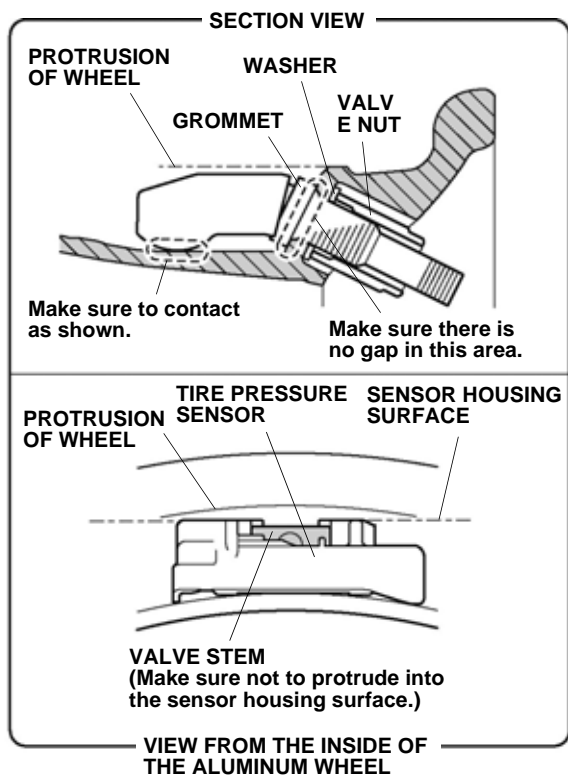

930404BR

4. Install the tires according to the instructions in the service information.
5. Install the wheels on the vehicle, and torque to 127 N·m (94 lb·ft).

If the vehicle is equipped with standard 18" wheels, continue with step 6; with standard 19" wheels, go to step 17.

With standard 18" Wheels

6. Open the driver's door. Using isopropyl alcohol on a shop towel, clean the area where the tire and loading information label will attach. Remove the adhesive backing from the label, and attach it over the standard tire and loading information label.

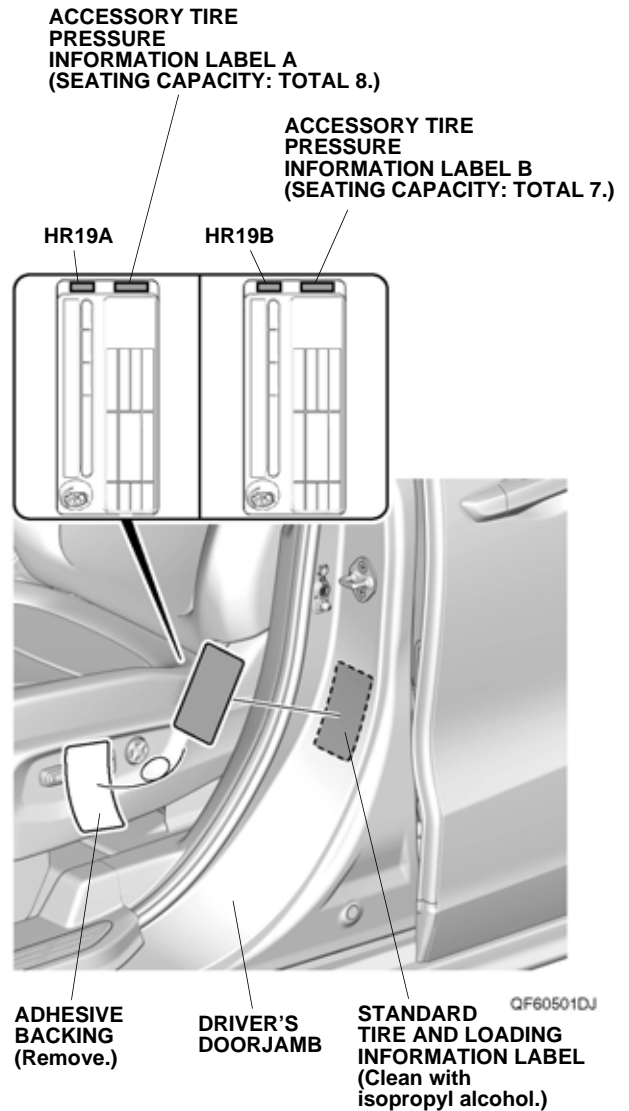

Tire Pressure Programming (Low Air Pressure Warning Threshold Reprogramming)

7. Connect the i-HDS to the OBD II data link connector, then turn the ignition to on.



Select System Selection.

QG42101AT

8. Start the Honda Diagnostic System.
9. Select **System Selection**.
10. Select **TPMS**, and click the check button.

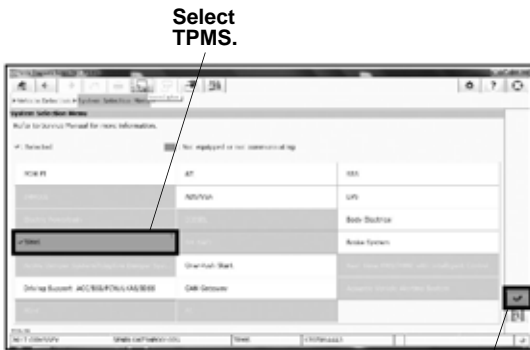

Select TPMS.

CHECK BUTTON

QG42102AT

11. Select **Threshold Rewriting**, and click the check button.

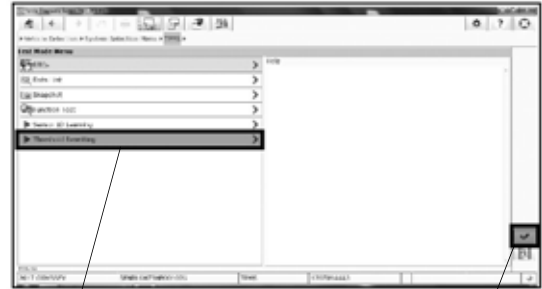

Select Threshold Rewriting.

CHECK BUTTON

QG42103AT

12. Select **Threshold Data Rewrite**, and click the check button.

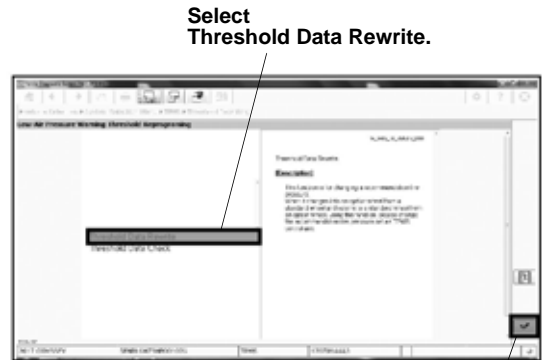

Select Threshold Data Rewrite.

CHECK BUTTON

QG42104AT

13. Enter the 10-digit tire information code printed on the tire and loading information label, and click the check button.

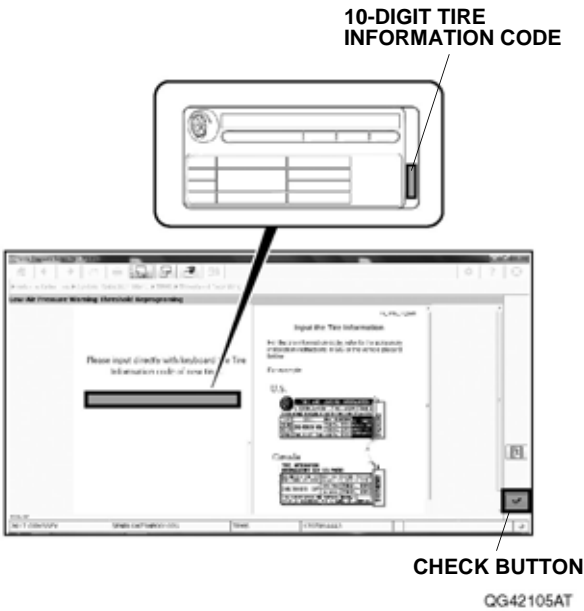

14. Check that the air pressure setting shown on the i-HDS and the new tire pressure information from the tire and loading information label are the same. Select **YES**.

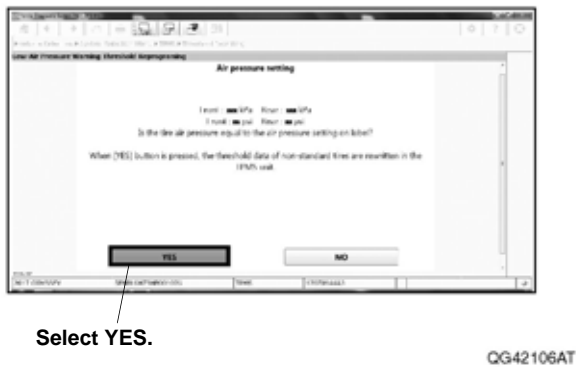

15. Check that the current air pressure setting shown on the i-HDS is correct, and click the check button.

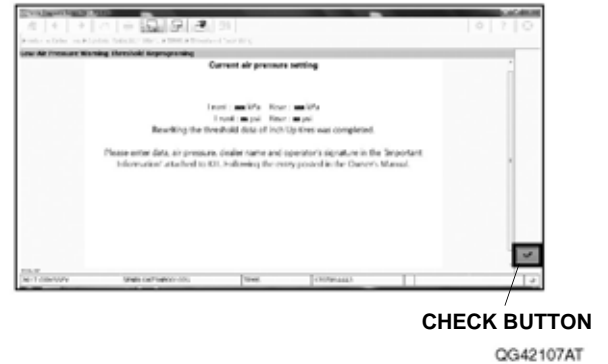

16. Disconnect the i-HDS.
17. Drive the vehicle for at least 40 seconds at a speed of 15 mph (24 km/h). All sensor IDs will be memorized automatically.