



## INSTALLATION INSTRUCTIONS

Accessory  
**CROSS BARS**  
P/N 08L04-TK8-100

Application  
**2013 ODYSSEY**

Publications No.  
**All 13268**  
Issue Date  
**AUG 2012**

### PARTS LIST

Front cross bar

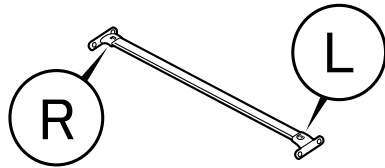

Rear cross bar

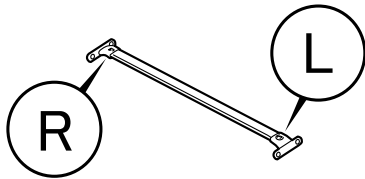

8 Bolts

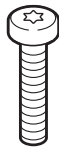

### TOOLS AND SUPPLIES REQUIRED

T-30 Torx driver

### Illustration of the Cross Bars on the Vehicle

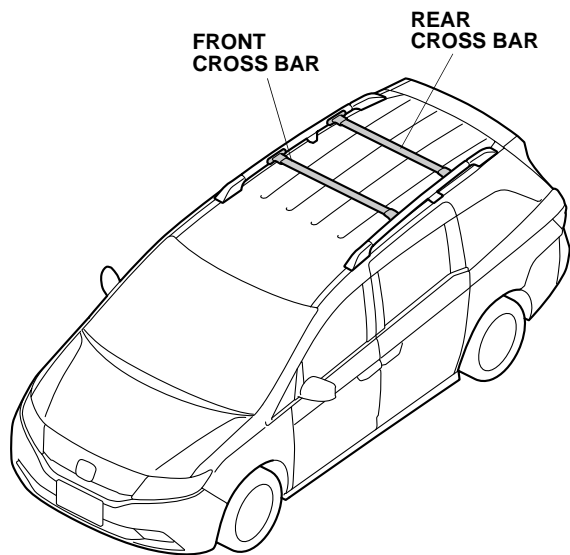

### INSTALLATION

#### NOTE:

- The weight of the cargo must not exceed the maximum weight capacity of 75 kg (165 lbs).
- Be extremely careful not to damage the roof and other finished surfaces of the body when installing the cross bars.

#### Installing the Cross Bars

1. Remove the eight plastic screws from the left side, and right side roof rails.

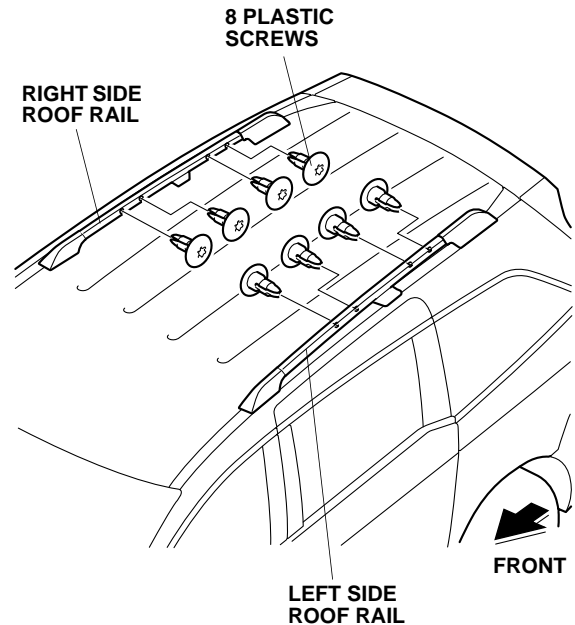

2. Install the front cross bar to the left side and right side roof rails with four bolts.  
Torque the bolts to: 10 N·m (7.3 lbf·ft)

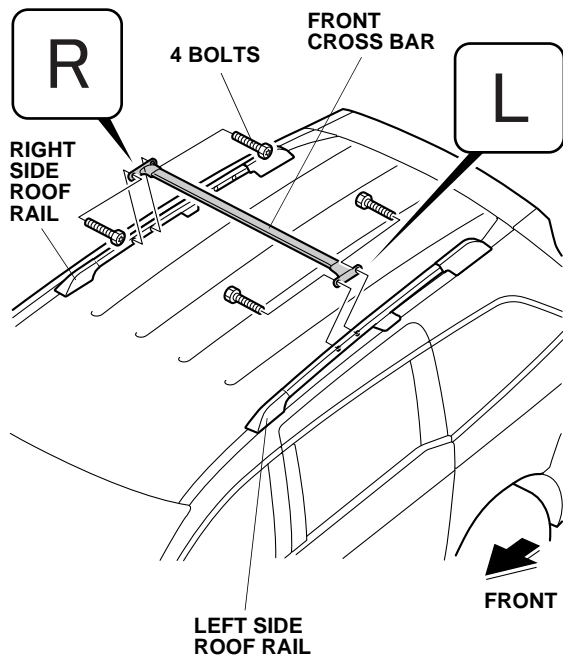

## USE AND CARE

- Check the roof rail mounting bolts frequently, and re-tighten if necessary.
- Distribute the weight of the cargo evenly, and do not exceed the maximum weight capacity of 75 kg (165 lbs).

3. Install the rear cross bar to the left side and right side roof rails with four bolts.  
Torque the bolts to: 10 N·m (7.3 lbf·ft)

