



INSTALLATION INSTRUCTIONS

Accessory
FRONT UNDER SPOILERS
P/N 08F01-TXM-100

Application
2020 INSIGHT

Publications No.
VERSION 1
Issue Date
SEP 2019

PARTS LIST

Left front under spoiler



Right front under spoiler



4 Female clips



4 Clips



4 Self-tapping screws



4 Spring nuts



4 Washers



2 Alcohol wipes



TOOLS AND SUPPLIES REQUIRED

Phillips screwdriver

5 mm Hex wrench

Pushpin

Drill

File

10 mm Open end wrench

Masking tape

3 mm, 6 mm, 8 mm, and 10 mm Drill bits

Eye protection (face shield, safety goggles, etc.)

Blanket

Ratchet

10 mm Socket

Shop towel

Ruler

Diagonal cutters

The following tools are available through the Honda Tool and Equipment Program. On the iN, click on Service > Service Bay > Tool and Equipment Program, then enter the number under "Search." Or, call 888-424-6857.

- Trim Tool Set (T/N SOJATP2014)
- Plastic Trim Tool (T/N SILTRIMTL10)
- Rubber Roller (T/N MHLE54D)

Illustration of the Front Under Spoilers Installed on the Vehicle



INSTALLATION

Customer Information: The information in this installation instruction is intended for use only by skilled technicians who have the proper tools, equipment, and training to correctly and safely add equipment to your vehicle. These procedures should not be attempted by "do-it-yourselfers."

NOTE:

- Be careful not to damage the body paint finish.
- This kit should be installed only if the ambient air temperature is 60°F (15°C) or above.
- To allow the adhesive to cure, do not wash the vehicle for 24 hours. Make sure your customer is aware of this.

1. Remove the right side panel, and disconnect the negative cable from the battery. Wait at least 3 minutes before you start to install the front under spoilers.

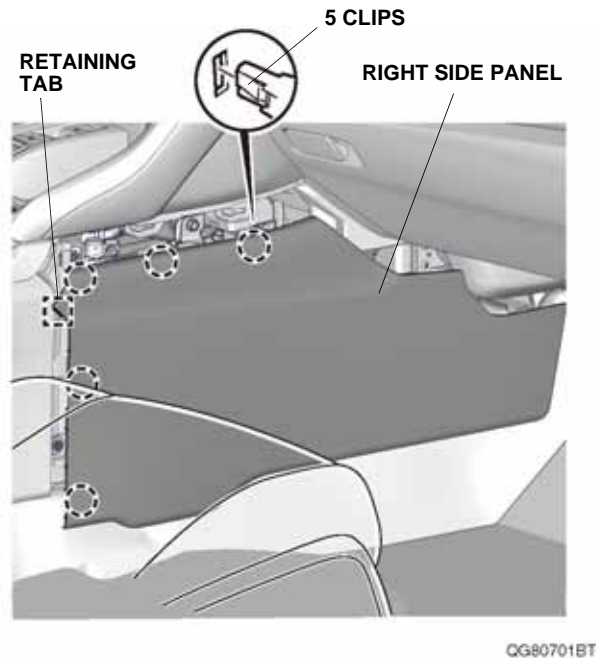

2. Remove the front bumper.
 - Apply masking tape as shown.
 - Wrap a shop towel around the hood latch.

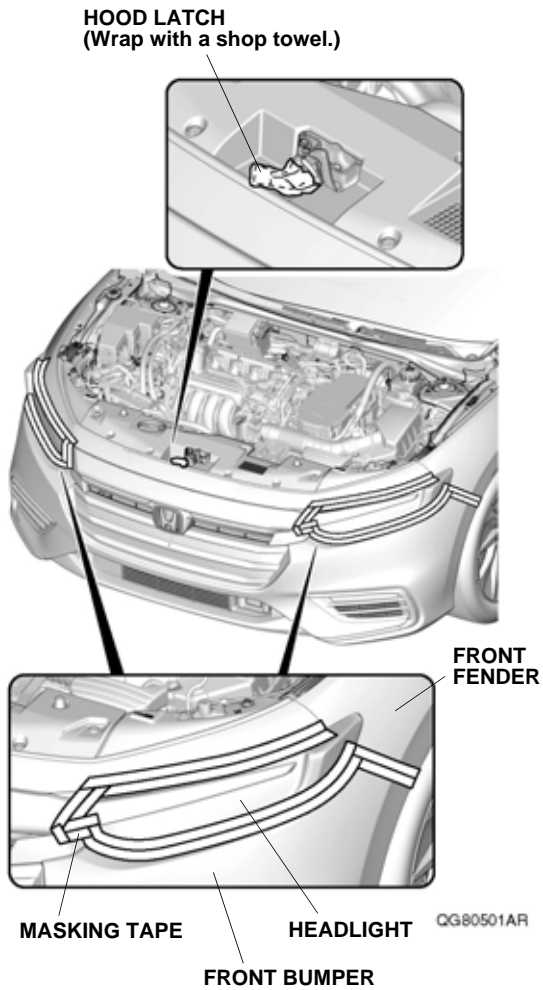

- Remove the front bulkhead cover.

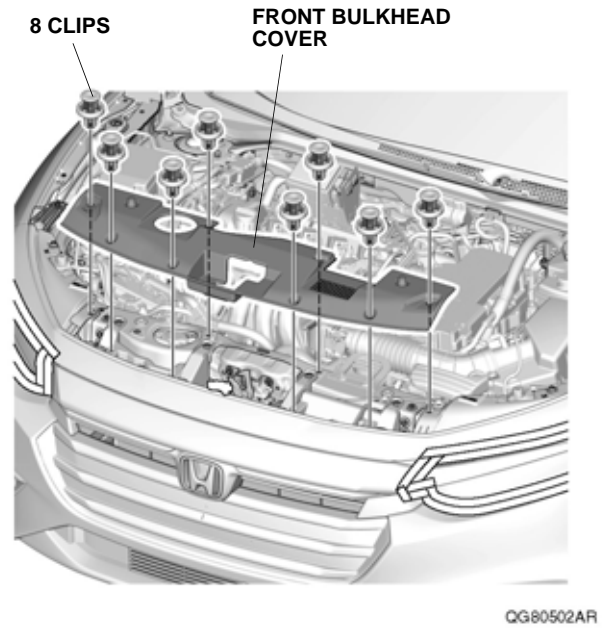

- Remove the millimeter wave radar cover.

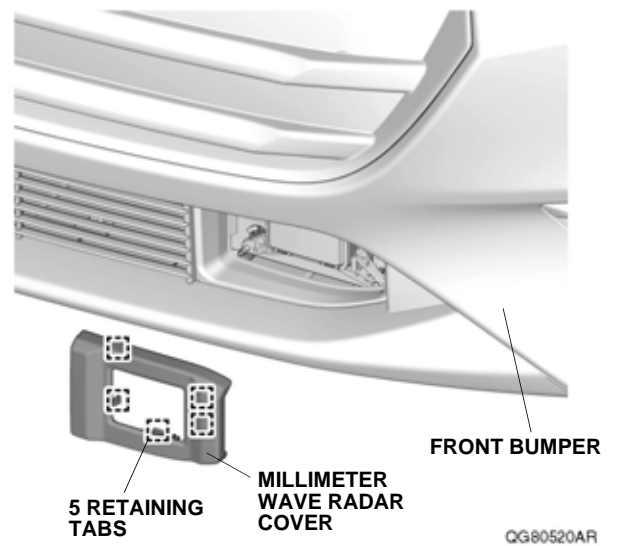

- Remove the two bolts and 12 clips.

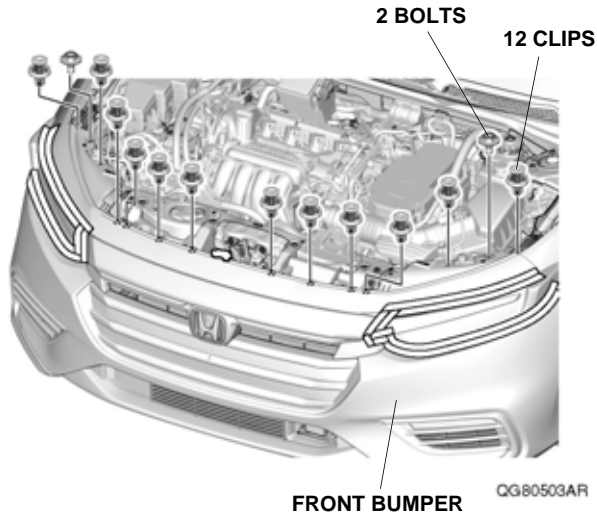

- Remove the four self-tapping screws, two hex bolts, and 11 clips.

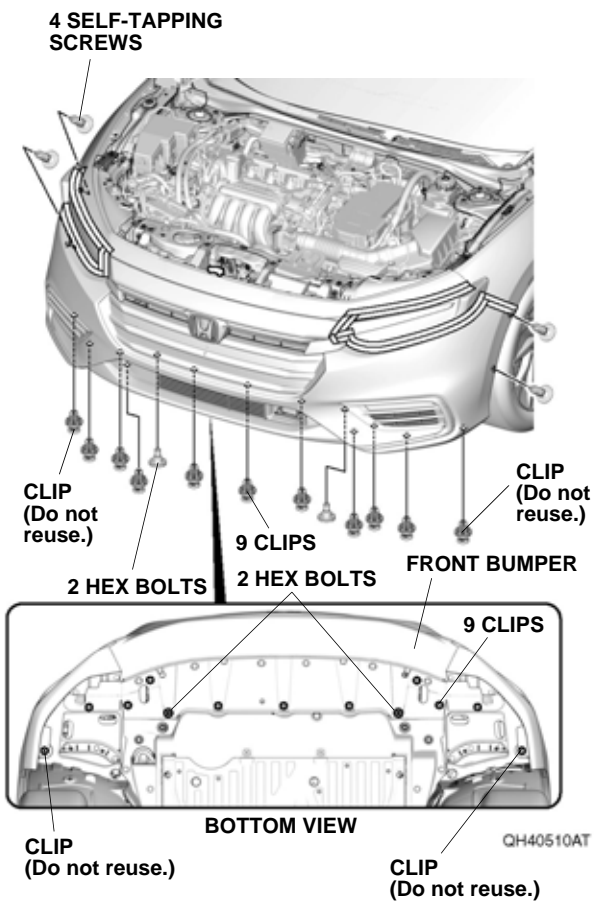

- With the help of an assistant, release the seven retaining tabs on each side.
NOTE: Make sure you remove and release the retaining tabs as shown.

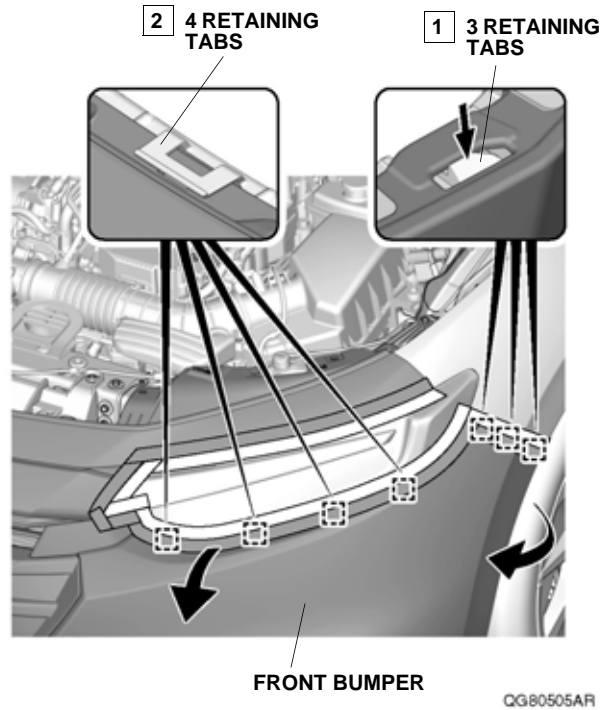

- With the help of an assistant, remove the front bumper using a plastic trim tool, and unplug the vehicle connectors (if equipped). Place the front bumper on a blanket to prevent damage.

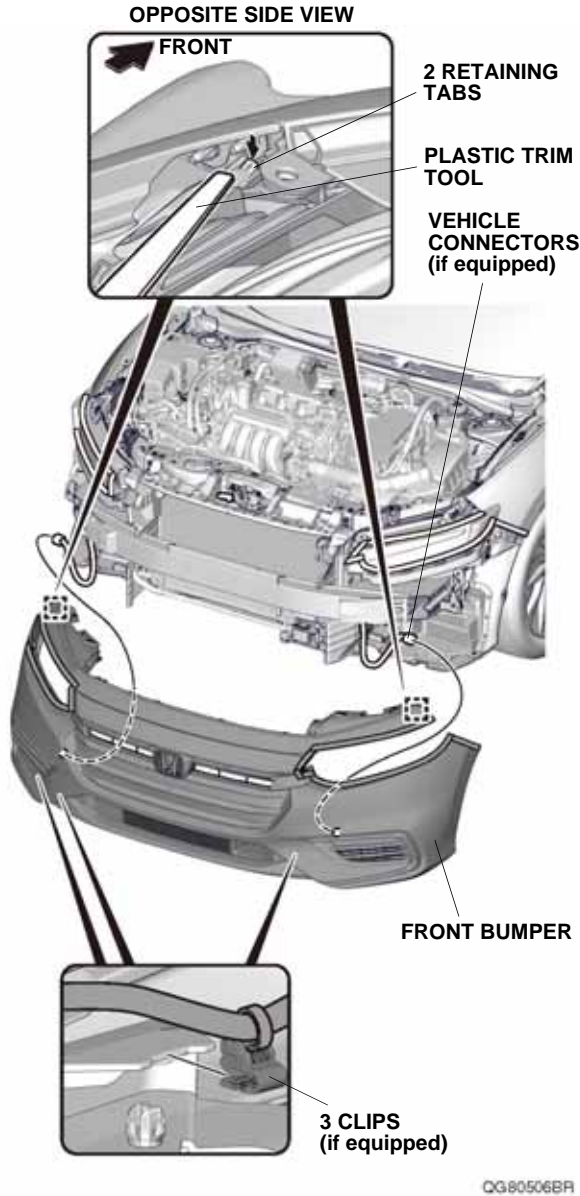

Installing the Front Under Spoilers

- Remove the front bumper lower grille.

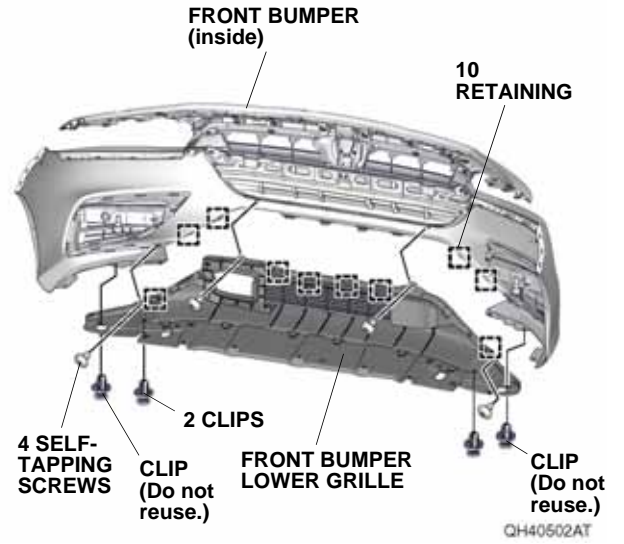

- Using a pushpin, pierce the inside of the front bumper through the center of four scribe marks.

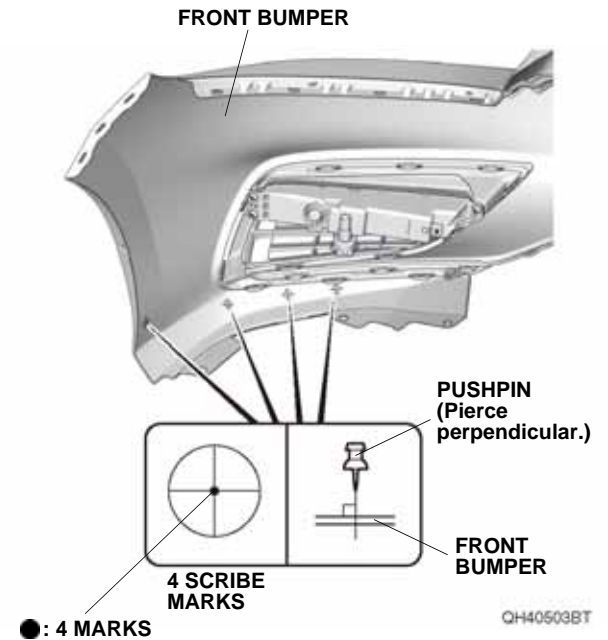

5. While wearing eye protection, drill the two pierced marks to 6 mm.

NOTE:

- Make sure to drill the correct locations.
- Wrap masking tape around each drill bit 10 mm (0.39 in.) away from the tip or use a drill stop.
- First drill with a 3 mm drill bit, then finish with a 6 mm drill bit.

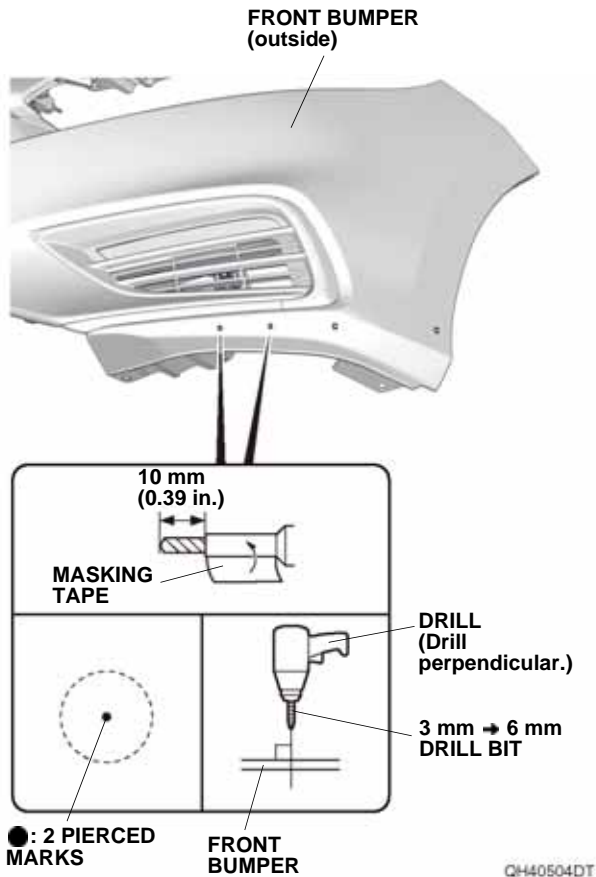

6. Using a file, remove any burrs from the holes.

7. While wearing eye protection, drill the two pierced marks to 10 mm.

NOTE:

- Make sure to drill the correct locations.
- Wrap masking tape around each drill bit 10 mm (0.39 in.) away from the tip or use a drill stop.
- First, drill with a 3 mm drill bit, then follow with a 6 mm drill bit, an 8 mm drill bit, and finish with a 10 mm drill bit.

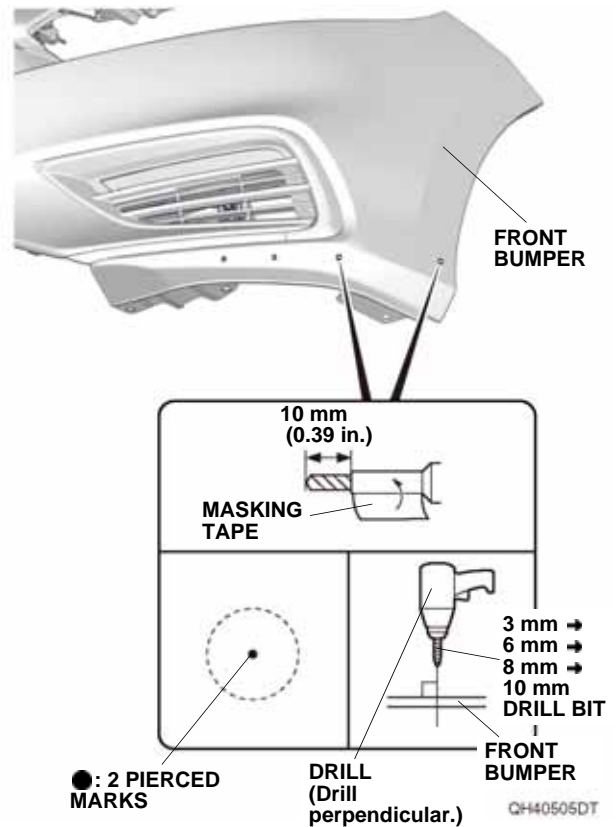

8. Using a file, remove any burrs from the holes.

9. Using an alcohol wipe, thoroughly clean the front bumper where the left front under spoiler will attach.

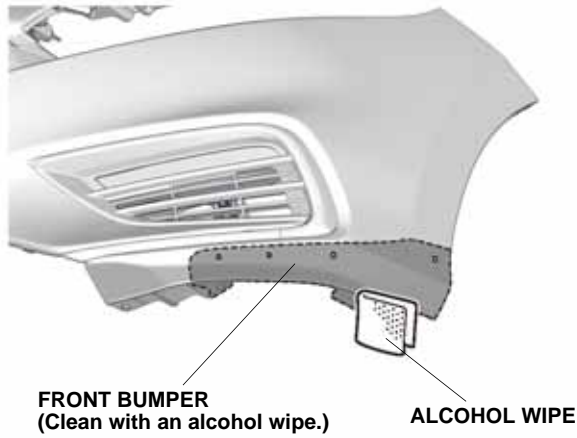

10. Install the two spring nuts on the left front under spoiler.
NOTE: Make sure to install the spring nut with the large hole facing out.

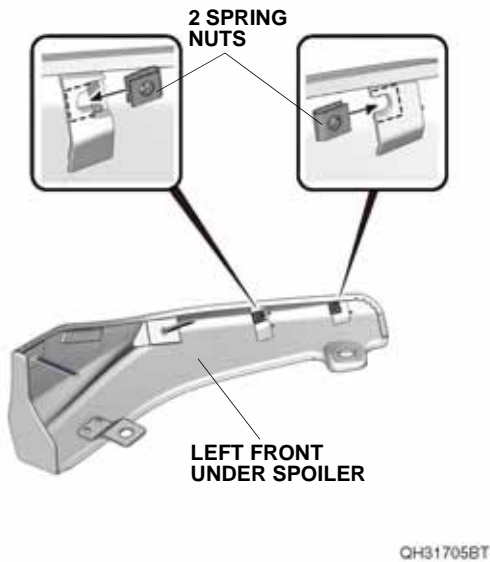

11. Peel back the adhesive backing, and tape it to the front surface of the left front under spoiler with masking tape.

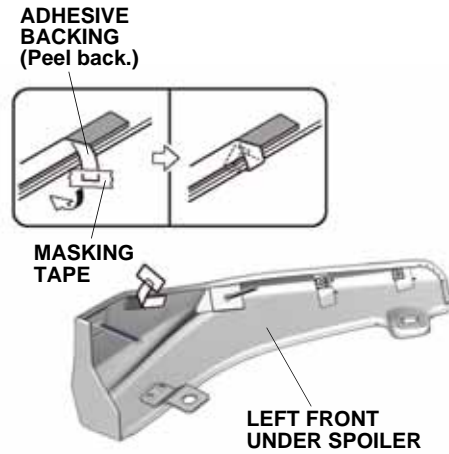

12. Install the left front under spoiler to the front bumper.

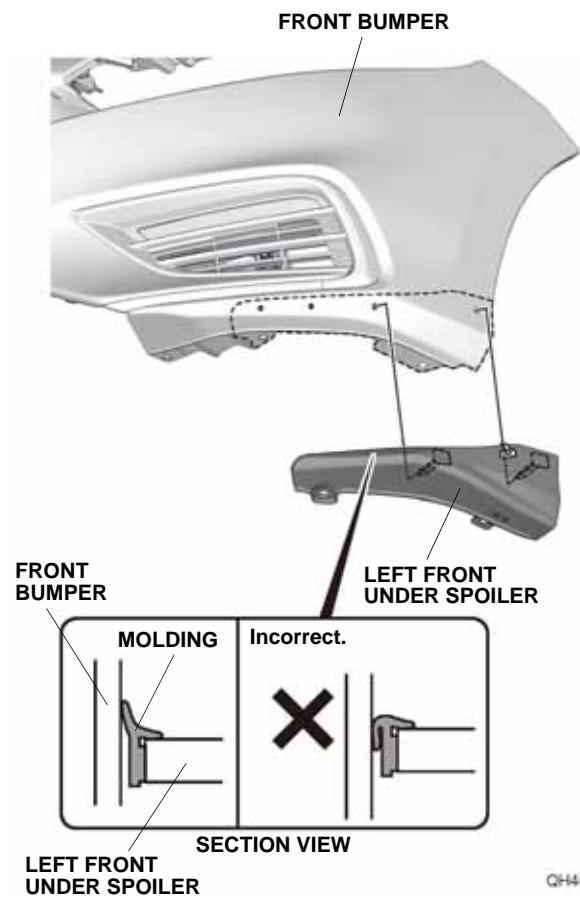

13. Secure the left front under spoiler to the front bumper with two female clips into each male clip as shown.
NOTE:

- Make sure to install the female clips in the correct orientation.
- Do not push the female clips too tight; you could deform the left front under spoiler. If necessary, readjust the female clips.

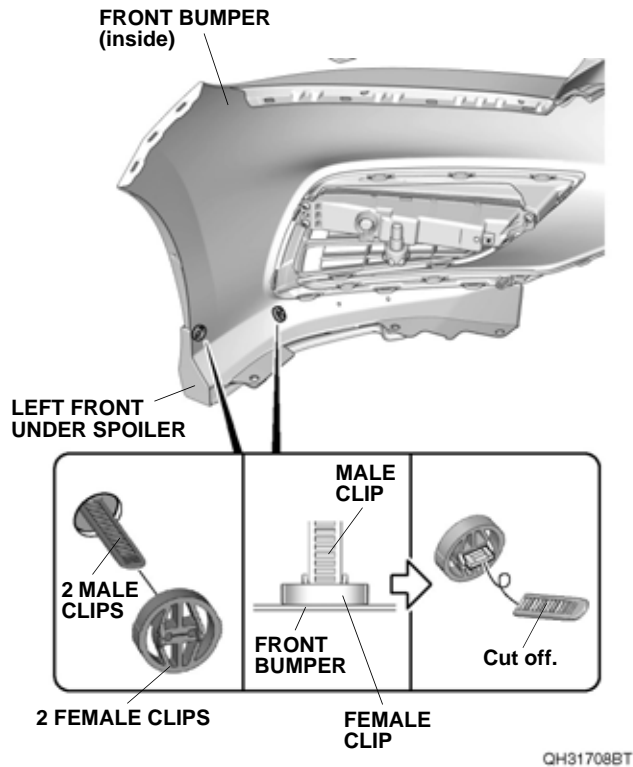

14. Secure the left front under spoiler to the front bumper with two self-tapping screws and two washers.

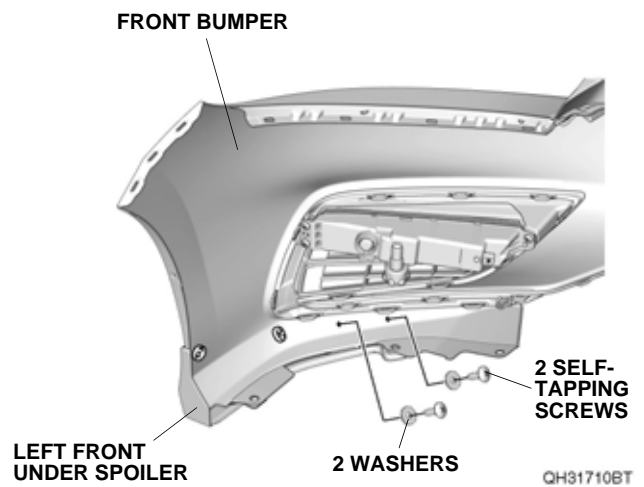

15. Repeat steps 4 through 14 on the right side of the front bumper.
16. Install the front bumper lower grille, and with the help of an assistant, install the front bumper.

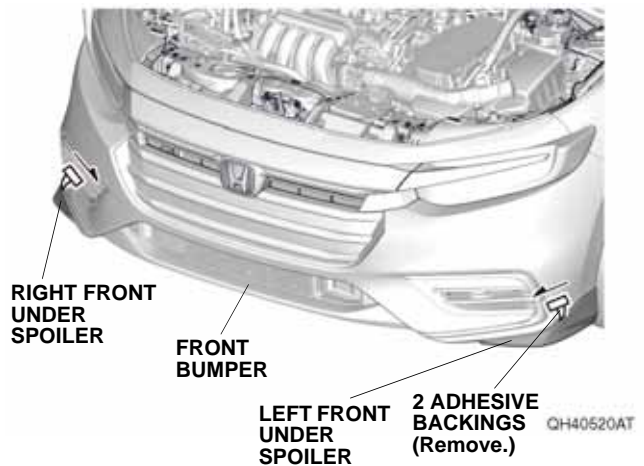

17. Remove the two adhesive backings. Press the right front under spoiler and left front under spoiler firmly against the front bumper with the palm of your hands.

18. Secure the left and right front under spoilers to the front bumper with the four clips.

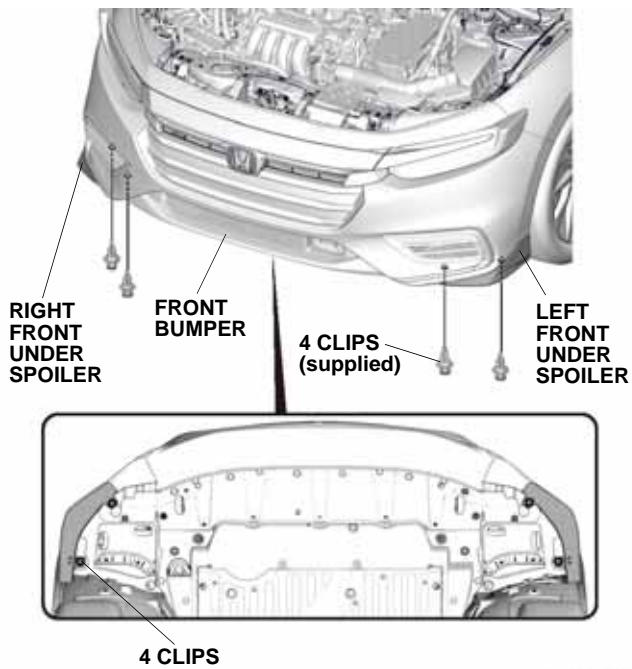

19. Using a rubber roller, apply firm pressure while rolling, especially at the ends, to set the adhesive.

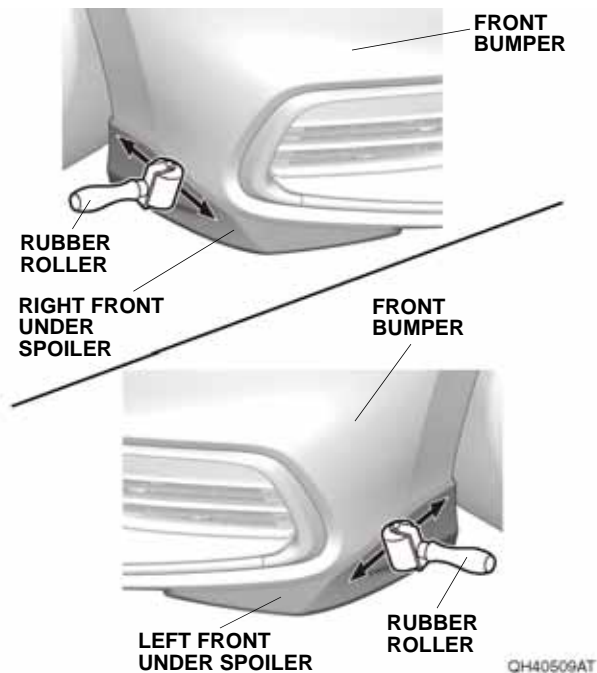

20. Check that all wire harnesses are routed properly and all connectors are plugged in.
21. Install all removed parts except for the right side panel.
22. Connect the negative cable to the battery.
23. Install the right side panel.
24. Press and hold the audio unit power button for 2 seconds to restore the audio and navi (if equipped) system functions.
25. Set the clock on vehicles without navigation.
26. If necessary, restore the systems back to normal operation as described in the service information.