



INSTALLATION INSTRUCTIONS

Accessory CARGO NET P/N 08L96-T7S-100	Application 2017 HR-V	Publications No. VERSION 1
		Issue Date SEP 2016

PARTS LIST

Cargo net



4 Snaps



2 Anchors



2 Stud bolts



2 Collars



2 EPT sealers



2 Rivet nuts



Accessory User's Information Manual



TOOLS AND SUPPLIES REQUIRED

10 mm and 19 mm Open end wrenches

Drill

3 mm, 6 mm, 8 mm, and 12 mm Drill bits

Eye protection (face shield, safety goggles, etc.)

File

Pushpin

Hex wrench

Ruler

Tape

Phillips screwdriver

Isopropyl alcohol

Shop towel

The following tools are available through the Honda Tool and Equipment Program. On the iN, click on: Service > Service Bay > Tool and Equipment Program, then enter the number under "Search." Or, call 888-424-6857.

- Plastic Trim Tool (T/N SILTRIMTL10)
- Rivet Nut Tool, 6 mm (T/N 07AAE-000A100)

INSTALLATION

Customer Information: The information in this installation instruction is intended for use only by skilled technicians who have the proper tools, equipment, and training to correctly and safely add equipment to your vehicle. These procedures should not be attempted by “do-it-yourselfers.”

NOTE: Be careful not to damage the paint finish.

1. Disconnect the negative cable from the battery.
2. Pull away the door opening seal. Remove the right rear door sill trim.

RIGHT REAR DOOR SILL TRIM

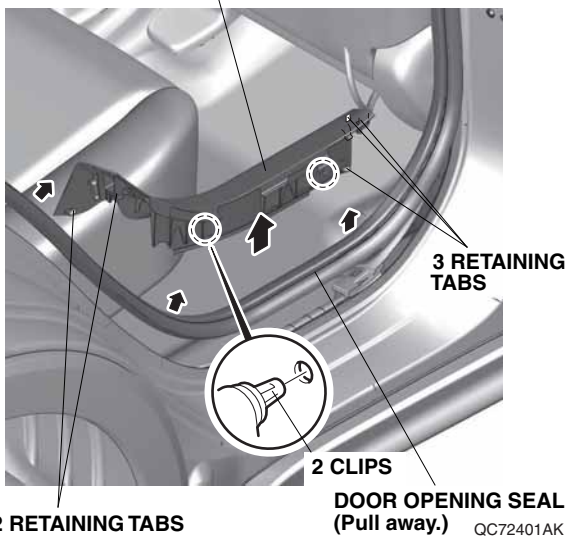

3. Repeat the same procedures for the other side.
4. Remove the tonneau cover, if equipped.

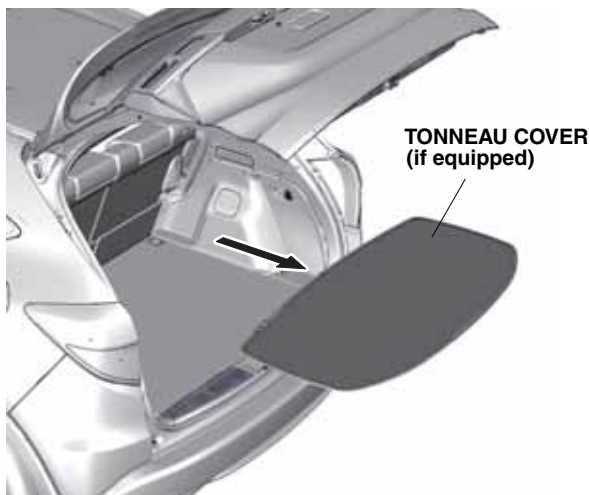

QC72410BK

5. Pull the knobs and fold each rear seat-back forward.

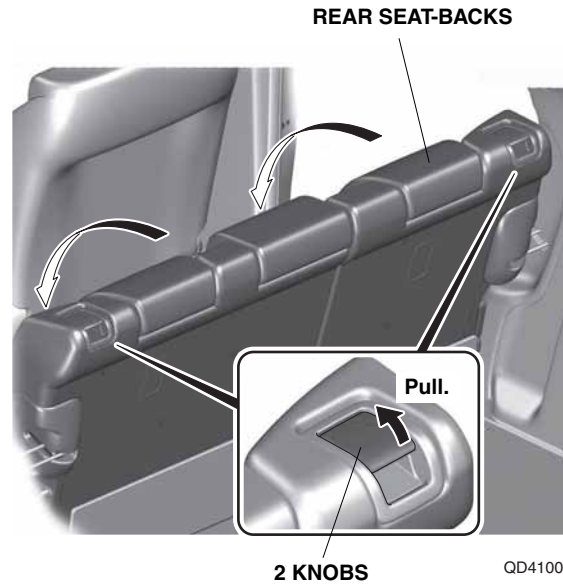

QD41003AK

6. Using a plastic trim tool, pry open the screw cover. Remove the tie-down hook (one screw). Remove the other tie-down hook.

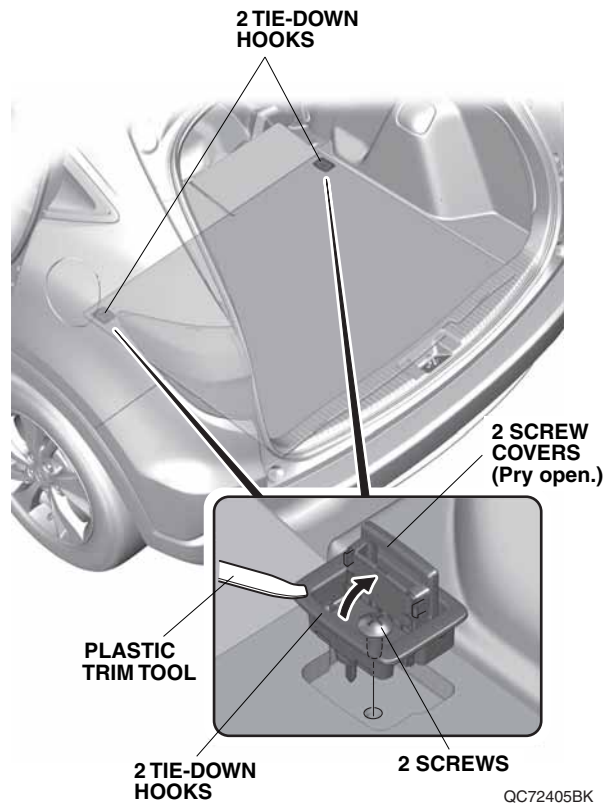

QC72405BK

7. Remove the cargo floor lid.

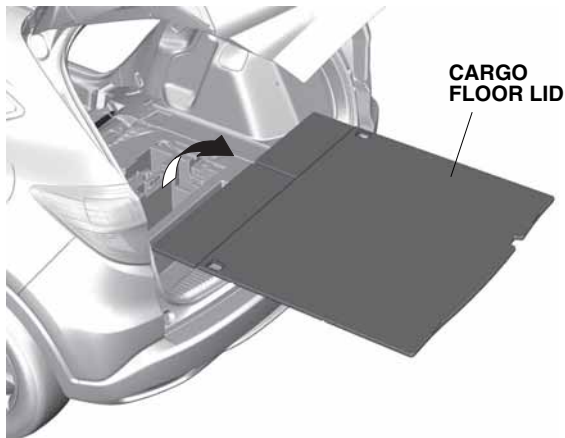

QC72406AK

8. Remove the tool box.

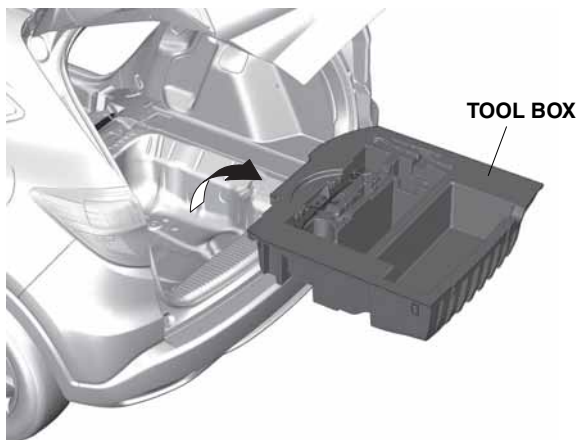

QC72407AK

9. Pull away the weatherstrip in the area shown. Remove the rear trim panel.

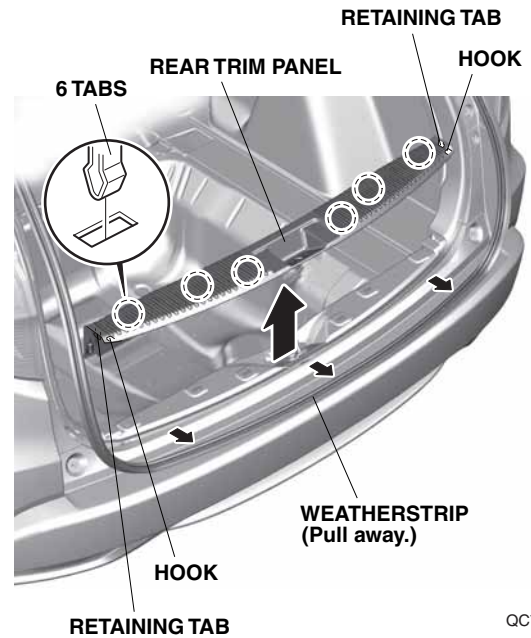

QC72408AK

10. Pull away the weatherstrip and the door opening seal. Remove the left rear side trim panel and unplug the vehicle connector, if equipped.

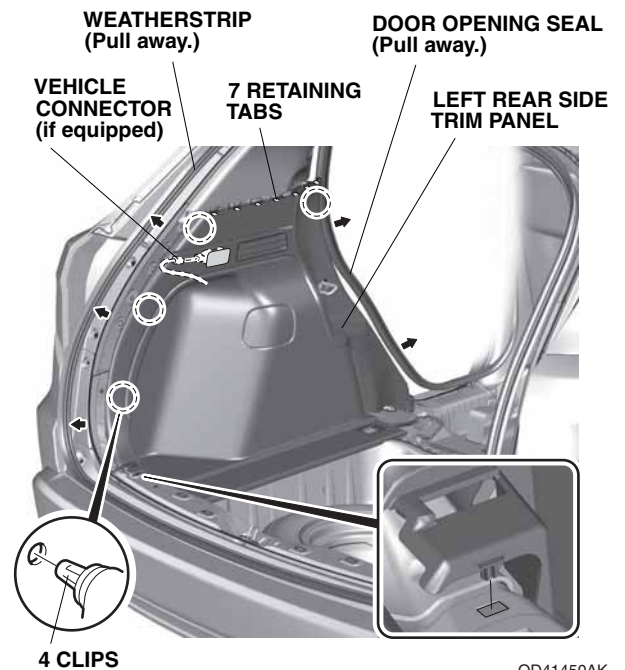

QD41450AK

11. Pull away the weatherstrip and the door opening seal. Remove the right rear side trim panel.

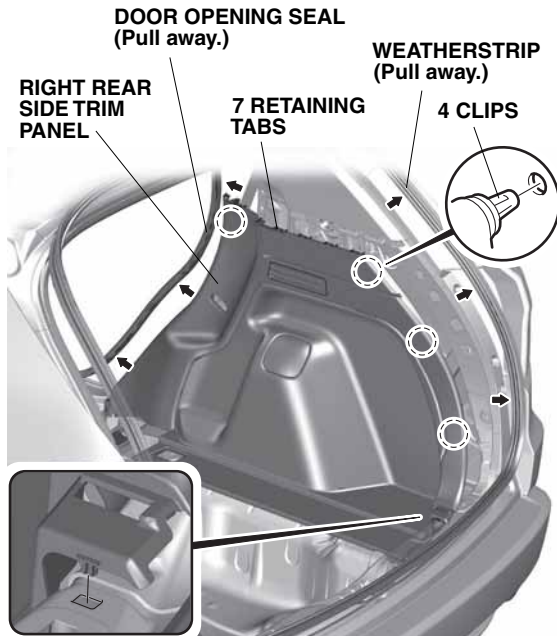

QC72409AK

Installing the Anchor

12. Using a pushpin, pierce one scribe mark on the left rear side trim panel as shown.

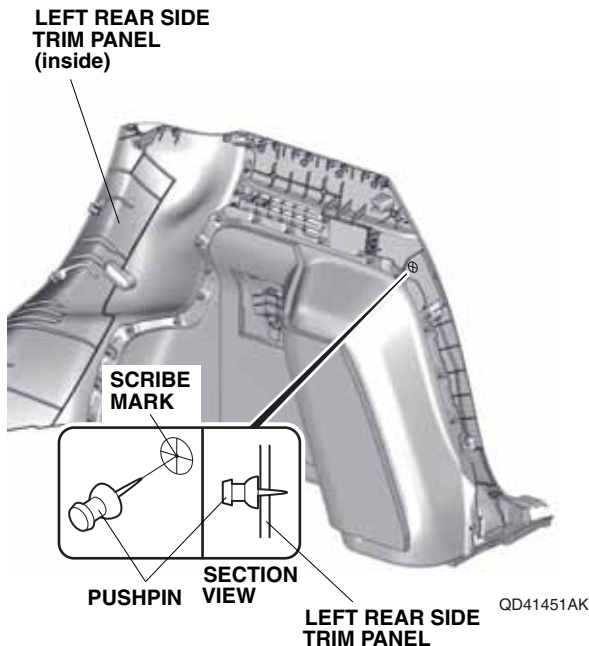

QD41451AK

13. While wearing eye protection, drill a 12 mm hole in the left rear side trim panel:
- Wrap tape around each drill bit 10 mm (0.4 in.) away from the tip or use a drill stop.
 - First drill with a 3 mm drill bit, then with a 6 mm drill bit, a 8 mm drill bit, and finish with a 12 mm drill bit.

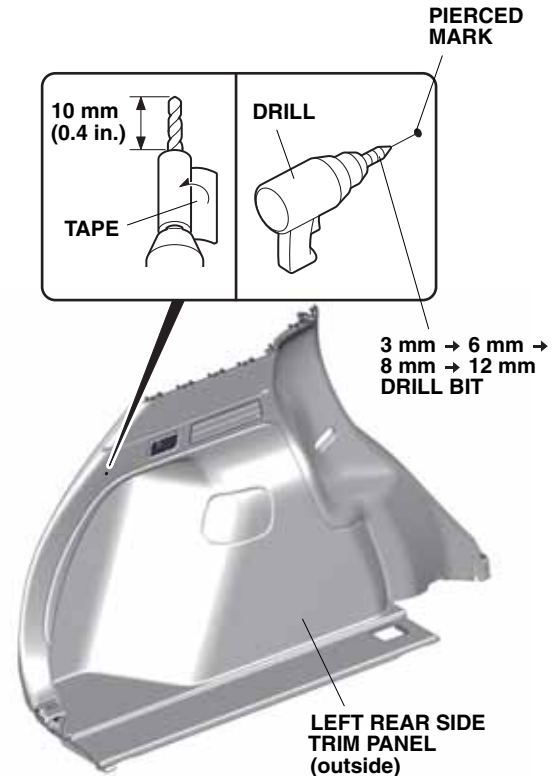

QD41452AK

14. Using a file, remove any burrs from the holes.

15. Thread the rivet nut onto the mandrel of the rivet nut tool as shown.

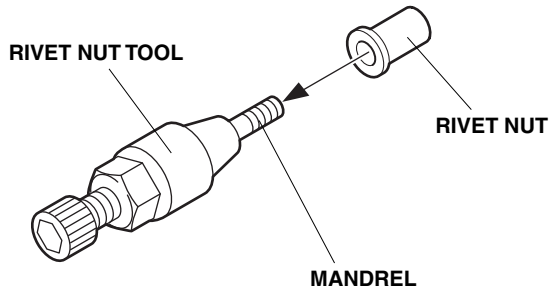

771013AE

16. Insert the rivet nut into the hole in the left side trunk panel and install the hex wrench on the rivet nut tool.

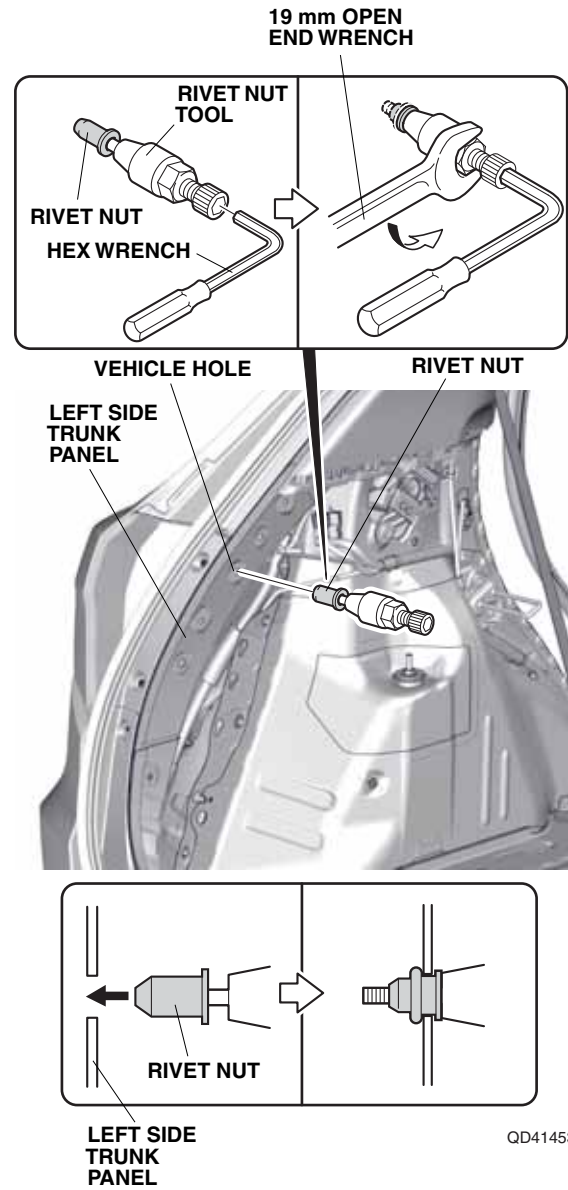

17. While holding the rivet nut tool with the hex wrench, turn the 19 mm wrench counterclockwise and install the rivet into the hole in the left side trunk panel. Remove the tool from the rivet nut by turning the hex wrench counterclockwise.
18. Install the left rear side trim panel.

19. Thread the stud bolt and collar as shown.

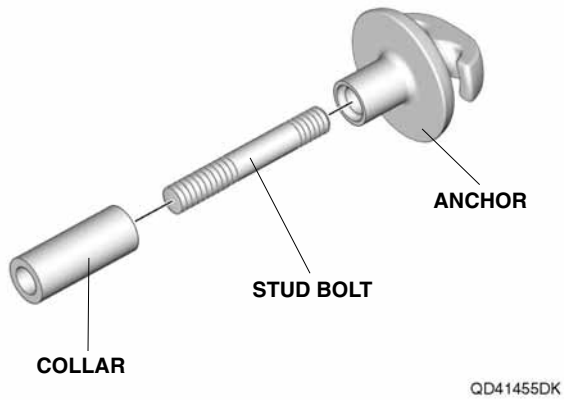

20. Install the EPT sealer onto anchor and thread the rivet nut onto the stud bolt. Adjust the anchor as shown.

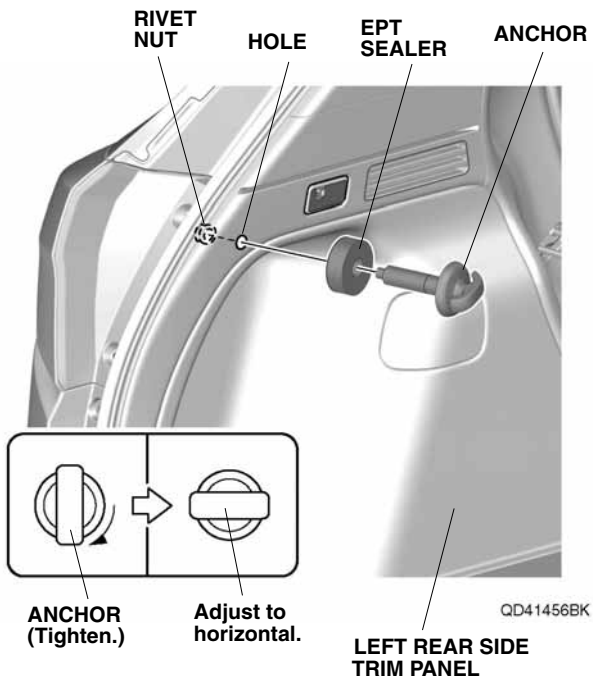

21. Repeat steps 12 through 20 to install the right side anchor.
 22. Install all removed parts, excepted the tonneau cover, if equipped.

Installing the Cargo Net

The cargo net can be installed in two positions.

Vertical Position:

- Attach the two snaps to the cargo net as shown.

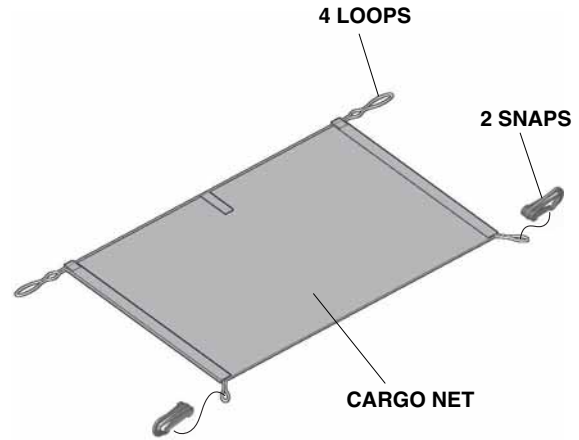

- Attach the top loops on the cargo net to the two anchors. Attach two snaps on the cargo net to the tie-down hooks.

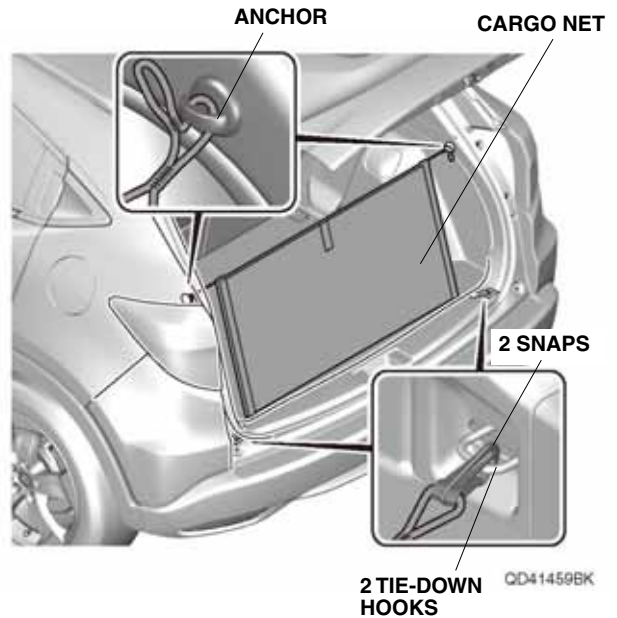

Horizontal Position:

- Attach four snaps to the cargo net as shown.

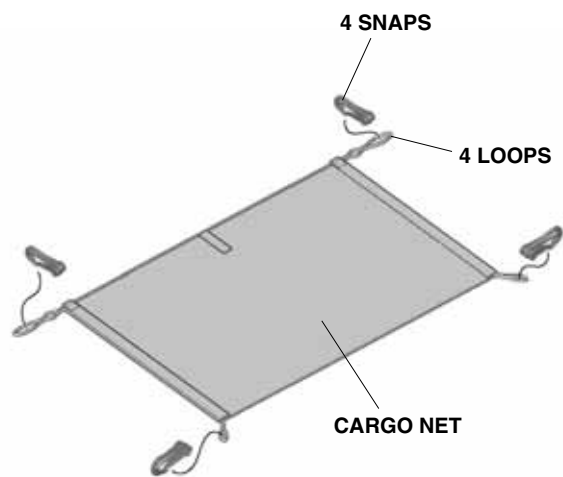

QD41458BK

- Attach the four snaps on the cargo net to the tie-down hooks as shown.

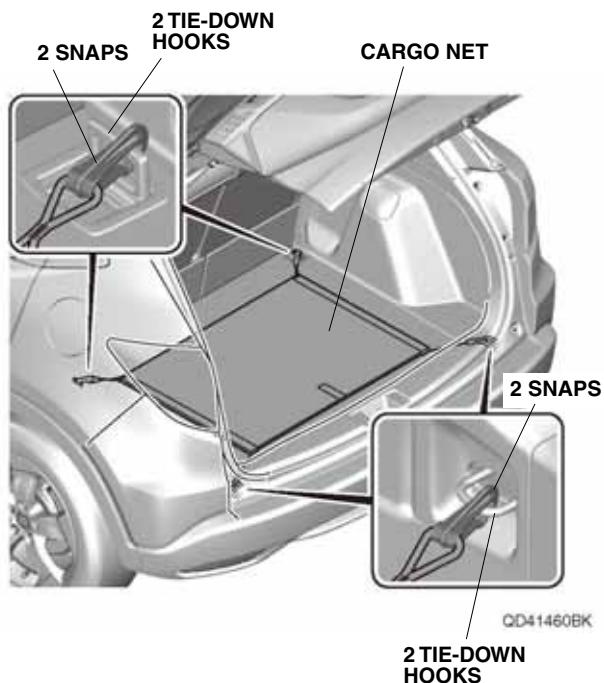

23. Check that all wire harnesses are routed properly and all connectors are plugged in.
24. Install the tonneau cover, if equipped.
25. Connect the negative cable to the battery.
26. Press and hold the audio unit power button for two seconds to restore the audio and navi (if equipped) system functions.
27. Set the clock on vehicles without navigation.
28. If necessary restore the systems back to normal operation as described in the service information.