



INSTALLATION INSTRUCTIONS

Accessory
SHIFT LEVER KNOB

Application
2018 FIT

Publications No.
VERSION 1
Issue Date
JUL 2017

PARTS LIST

Shift Lever Knob Kit
P/N 08U92-T5A-100

Shift lever knob



Shift Lever Boot Kit
P/N 08U92-T5A-100A

Shift lever boot



Ring



TOOLS AND SUPPLIES REQUIRED

10 mm and 17 mm Open end wrenches

Phillips screwdriver

Ratchet

10 mm Socket

Masking tape

Torque wrench

The following tools are available through the Honda Tool and Equipment Program. On the iN, click on Service > Service Bay > Tool and Equipment Program, then enter the number under "Search." Or, call 888-424-6857.

- Trim Tool Set (T/N SOJATP2014)
- Plastic Trim Tool (T/N SILTRIMTL10)

Illustration of the Shift Lever Knob Installed in the Vehicle

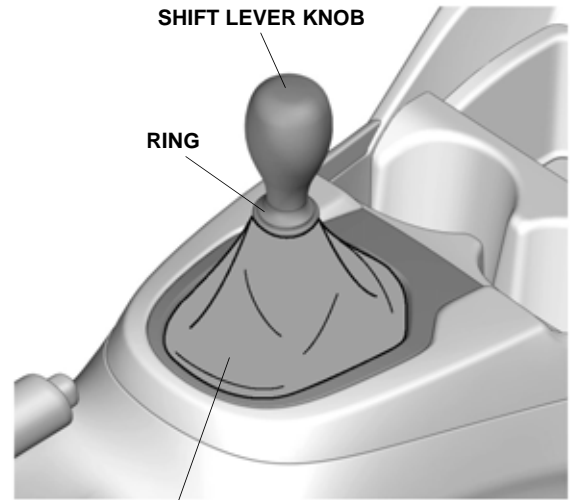

SHIFT LEVER KNOB
RING
SHIFT LEVER BOOT

GFD0801AT

INSTALLATION

Customer Information: The information in this installation instruction is intended for use only by skilled technicians who have the proper tools, equipment, and training to correctly and safely add equipment to your vehicle. These procedures should not be attempted by "do-it-yourselfers."

1. Disconnect the negative cable from the battery.

2. Open the glove box, push inward on the stops, and remove the glove box.

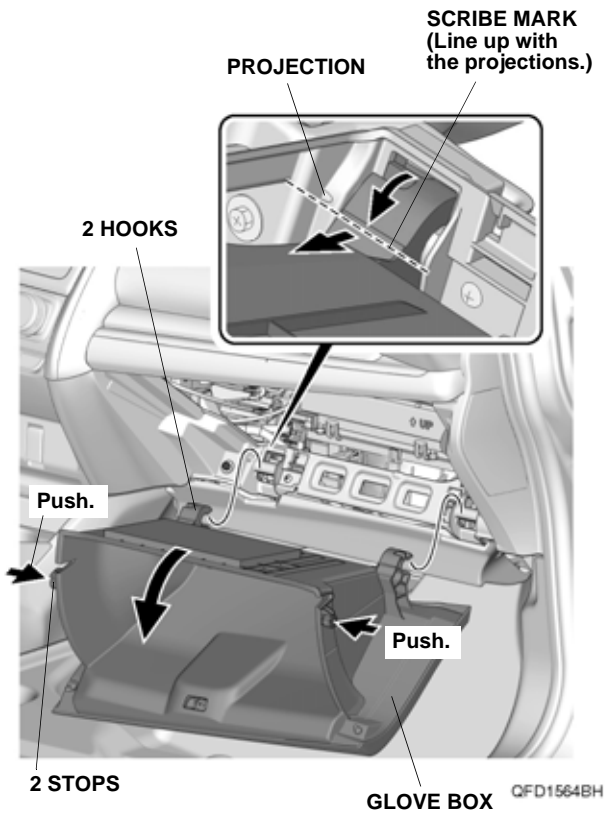

3. Apply masking tape as shown.



4. Remove the center lower cover, and unplug the vehicle connectors.

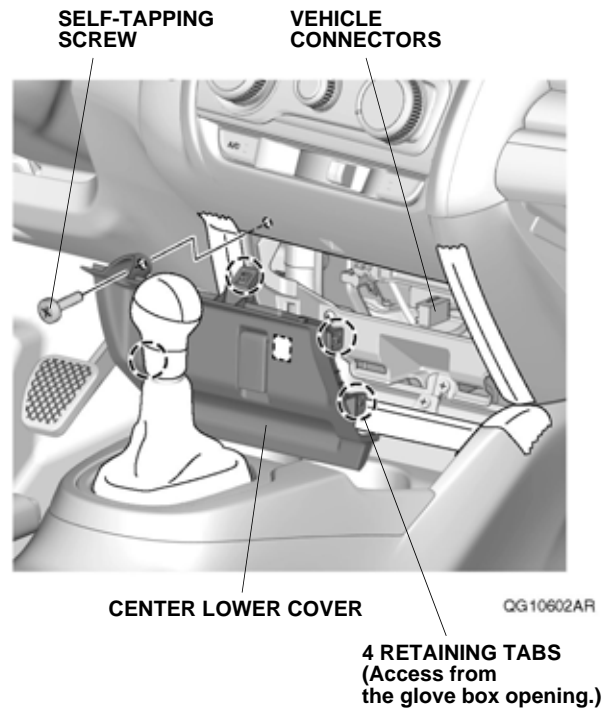

5. Remove the shift lever knob.

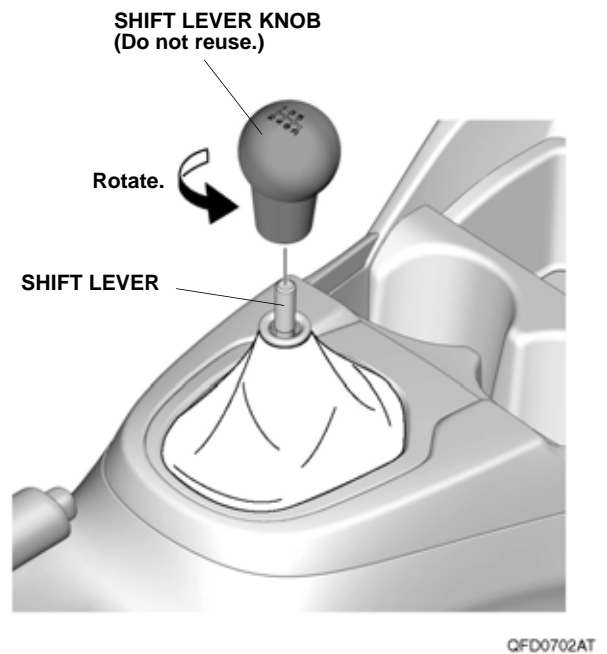

6. Remove the parking brake cover trim.

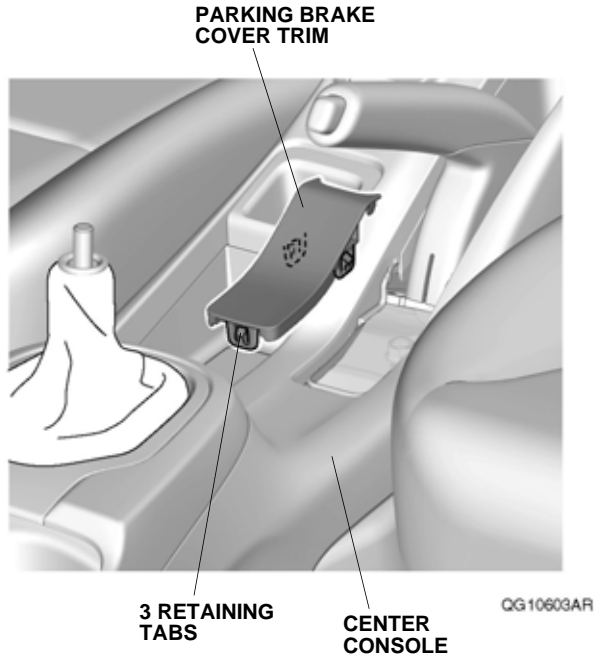

7. Remove the center console rear trim.

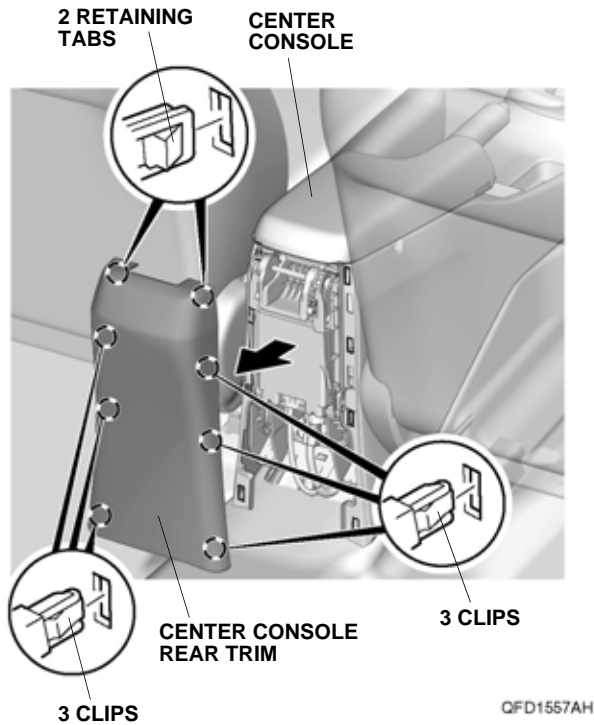

8. Remove the center console, and unplug the vehicle connectors.

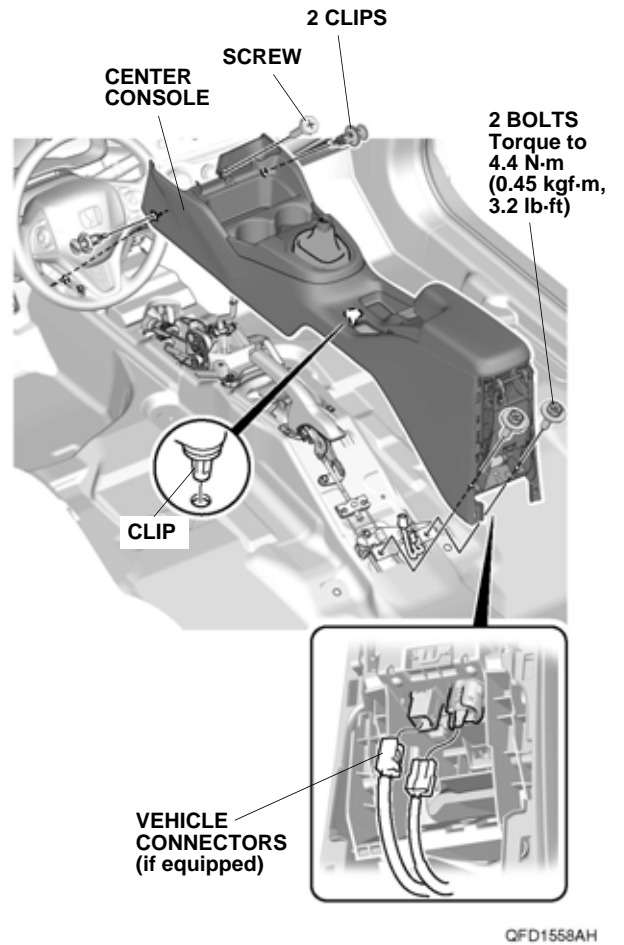

9. Remove the shift lever boot.

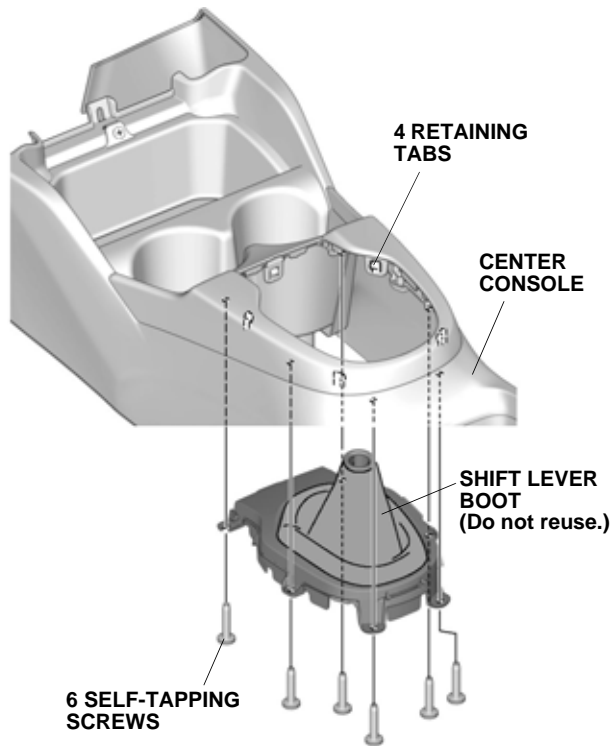

10. Secure the shift lever boot to the center console with the supplied screws.

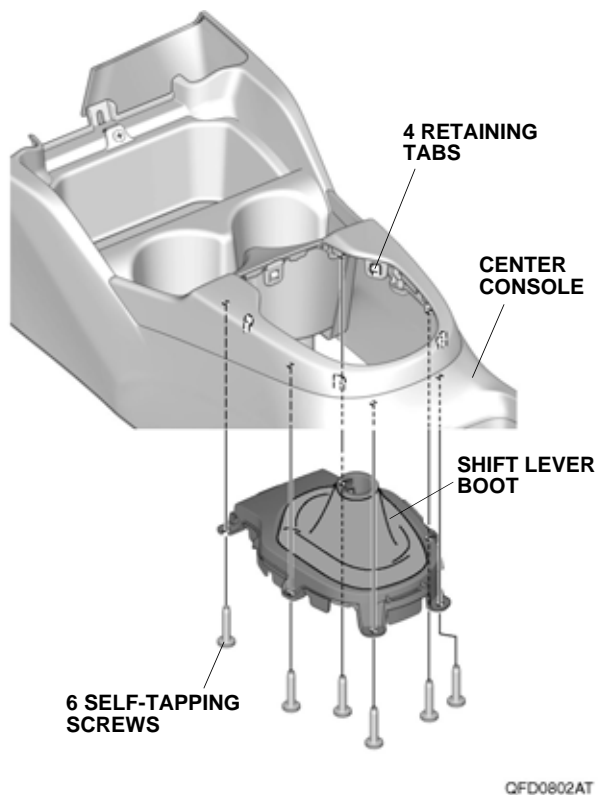

11. Install the center console. Then, install the ring on the shift lever as shown.

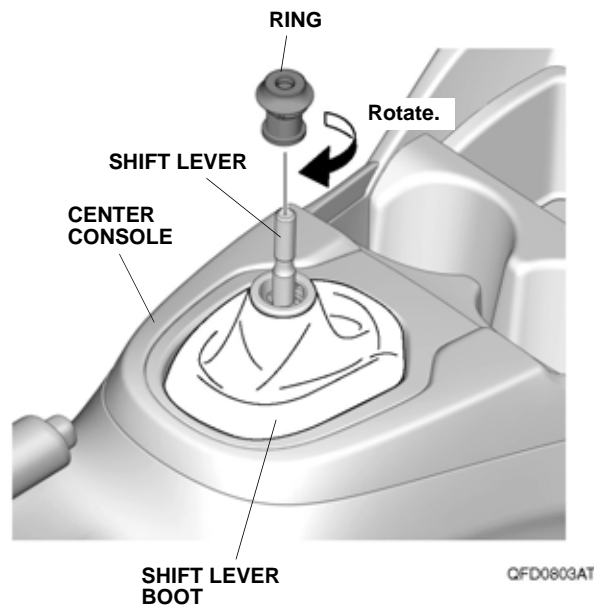

12. Install the shift lever knob on the shift lever, and tighten the ring as shown.

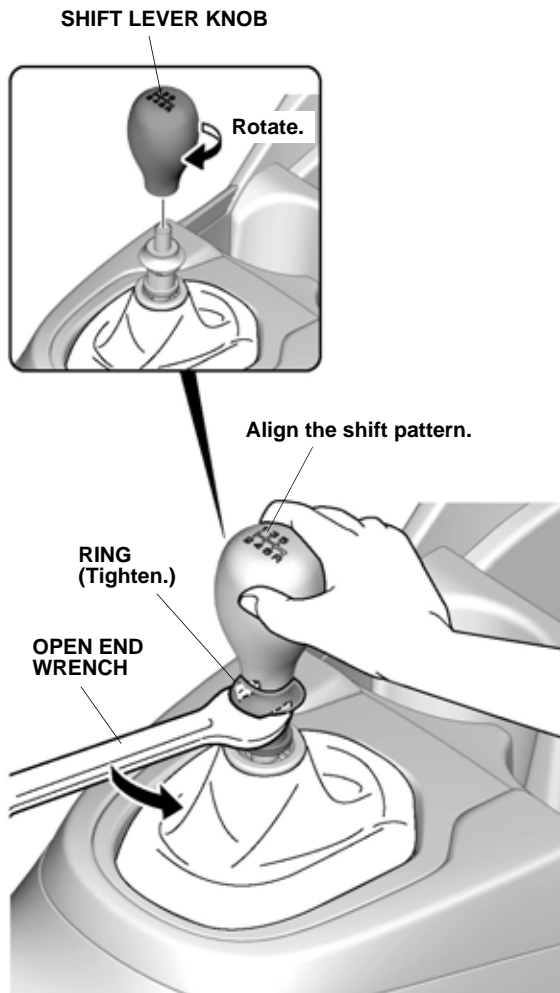

13. Secure the shift lever boot on the ring.

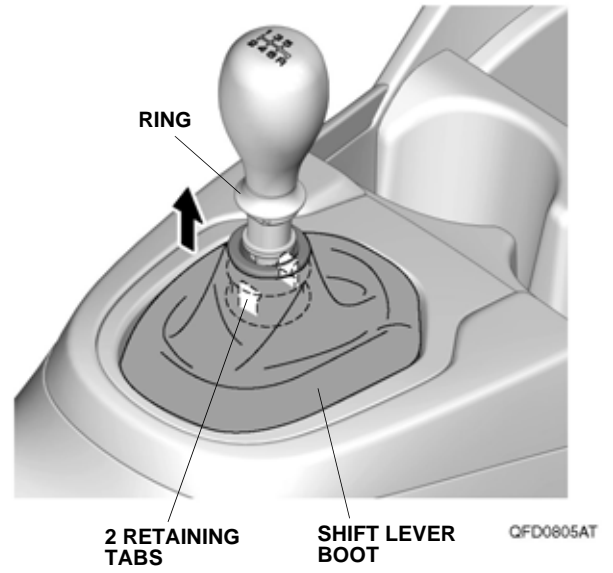

14. Check that all wire harnesses are routed properly and all connectors are plugged in.
15. Install all removed parts.
16. Connect the negative cable to the battery.
17. Press and hold the audio unit power button for 2 seconds to restore the audio and navi (if equipped) system functions.
18. Set the clock.
19. If necessary, restore the systems back to normal operation as described in the service information.

Check the Shift Lever Knob Operation

20. Make sure the shift lever knob is correctly orientated and the shift lever moves freely.

Put a copy of this page in the glove box for your customer.

CARE OF THE SHIFT LEVER KNOB

- Do not use volatile solvent (thinner, benzine, alcohol, gasoline, etc.). It may cause discoloration or strain.
- To clean it, wipe it with a soft cloth and mild soap solution, then wipe with the dampened towel.