



**INSTALLATION  
INSTRUCTIONS**

Accessory

**ARMREST CONSOLE  
P/N 08U89-TK6-110**

Application

**2009 FIT**

Publications No.

**All 39836**

Issue Date

**AUG 2008**

**PARTS LIST**

Armrest console

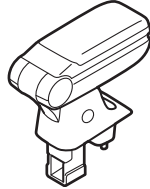

Floor bracket

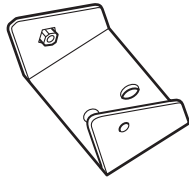

Console bracket

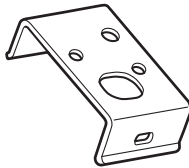

4 Washer bolts, 6 x 25 mm



2 Self-tapping screws



2 Center Console bolt covers

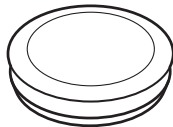

Base spacer

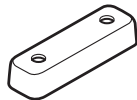

Armrest cover

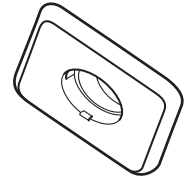

Bolt cover



Washer bolt, 10 x 30 mm



Owner's manual

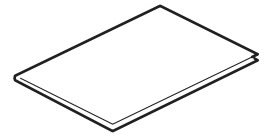

**TOOLS AND SUPPLIES REQUIRED**

Flat-tip screwdriver

Pushpin

Drill

3 mm and 8 mm Drill bits

File

Phillips screwdriver

20 mm Hole saw

10 mm, 12 mm, and 14 mm Sockets

Ratchet

Clip remover

Eye protection (safety goggles, face shield, etc.)

10 mm Combination wrench

Torque wrench

**INSTALLATION**

**Customer Information:** The information in this installation instruction is intended for use only by skilled technicians who have the proper tools, equipment, and training to correctly and safely add equipment to your vehicle. These procedures should not be attempted by “do-it-yourselfers.”

If the vehicle is equipped with a driver’s seat armrest, continue with step 1, otherwise go to step 5.

1. Remove the armrest bolt cover.

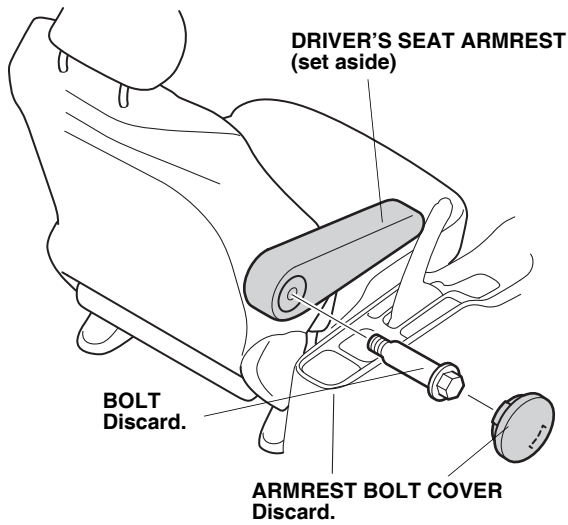

2. Remove the armrest bolt. Set the armrest aside, it will not be reused.
3. Remove and discard the two vehicle bolts.

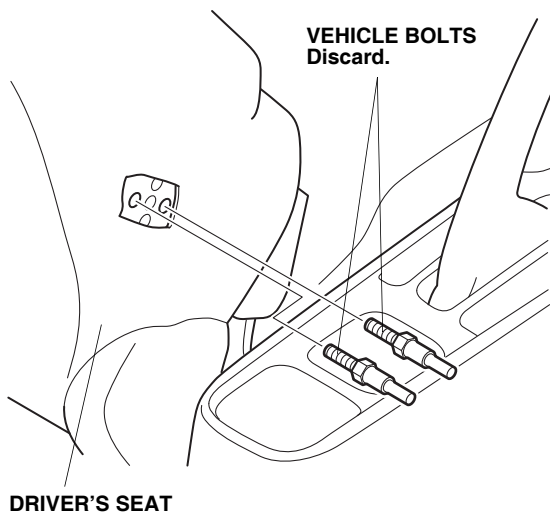

4. Place the new armrest cover over the seat and install the 10 x 30 mm washer bolt. Note the direction of the armrest cover. Install the new bolt cover over the bolt by engaging the back tab first.

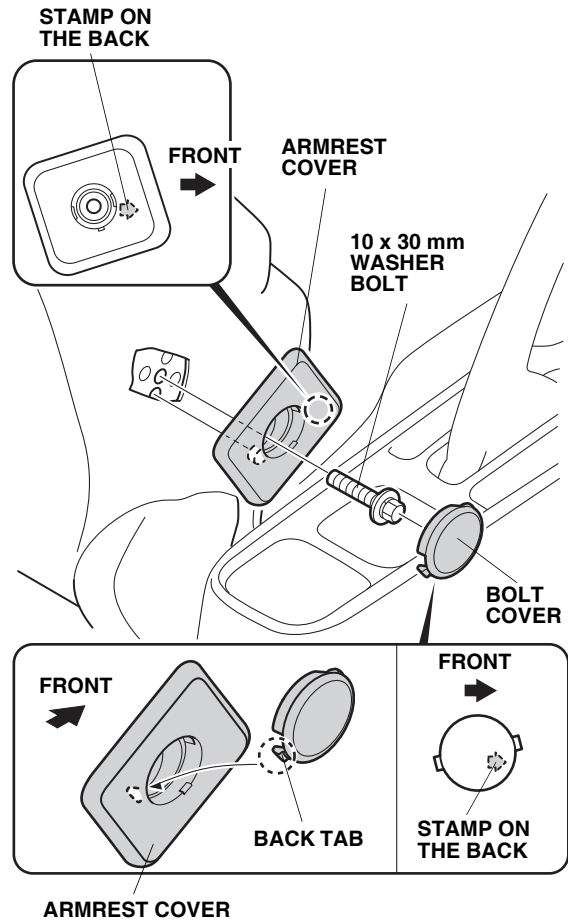

5. Remove the center console cover (three retaining tabs).

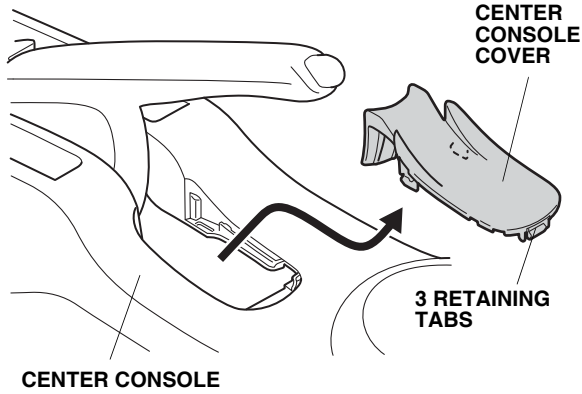

6. On M/T model, remove the shift knob.

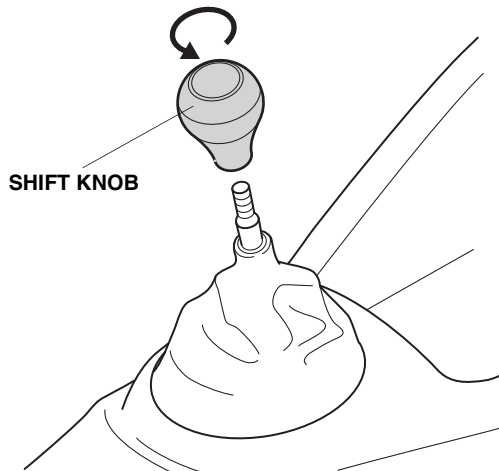

7. Remove the center console:
- Move the select lever to the "N" position.
  - Remove the two front clips.
  - Remove and discard the rear bolt insulator, and remove the bolt.
  - Gently pull the center console back, and carefully remove it.

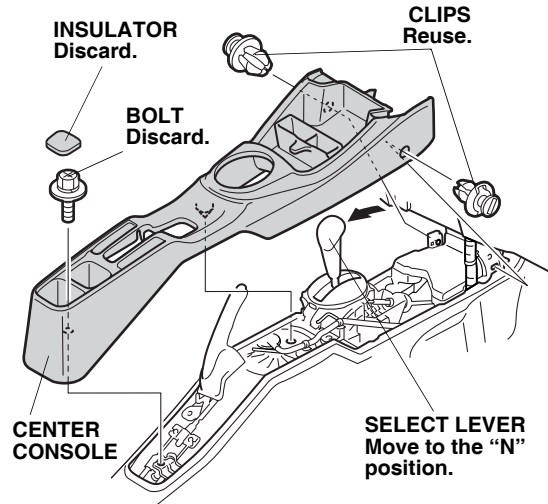

8. With the vehicle on level ground and the wheels blocked, release the parking brake. Remove the parking brake bracket (two bolts).

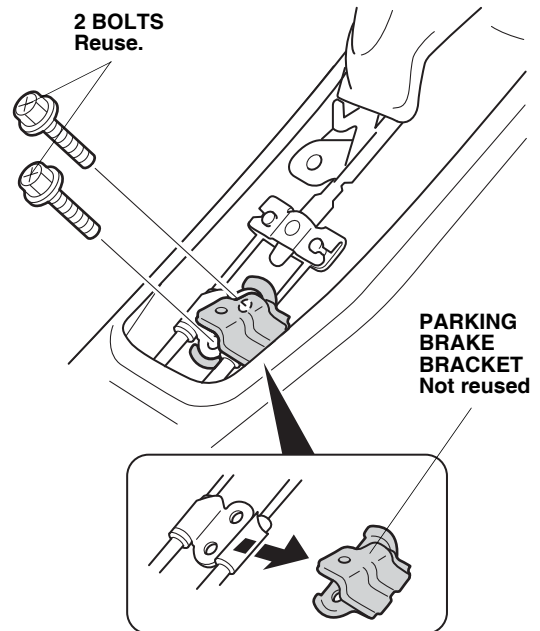

9. Install the floor bracket under the parking brake cables and reinstall the two bolts. Torque the bolts to 22 N·m (16 lb·ft). Be careful not to strip the threads.

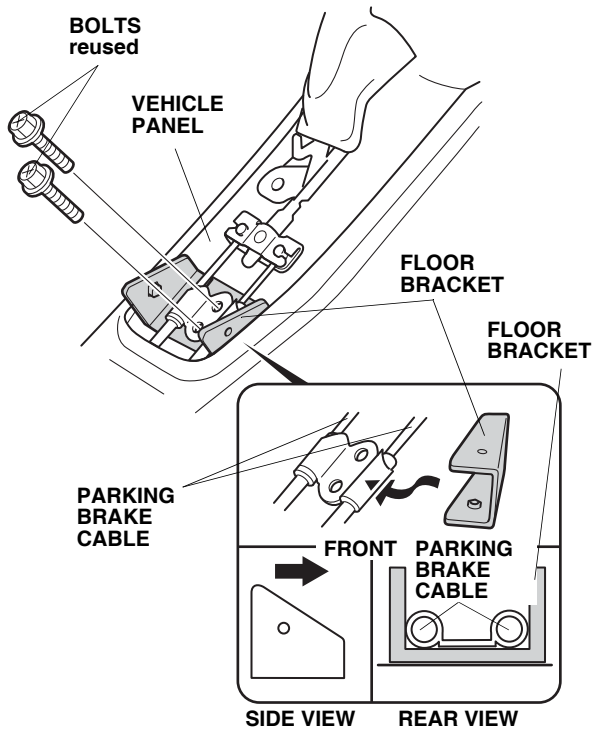

10. On the bottom of the center console locate the six preset marks using a pushpin, pierce at the center of each mark.

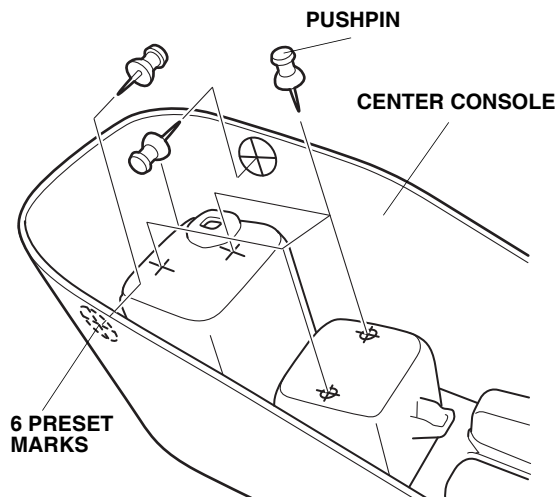

11. While wearing eye protection, drill the four pierced marks on the inside of the center console to 8 mm. First drill with a 3 mm drill bit, and finish with an 8 mm drill bit. Remove any burrs from the edge of the holes with a file.

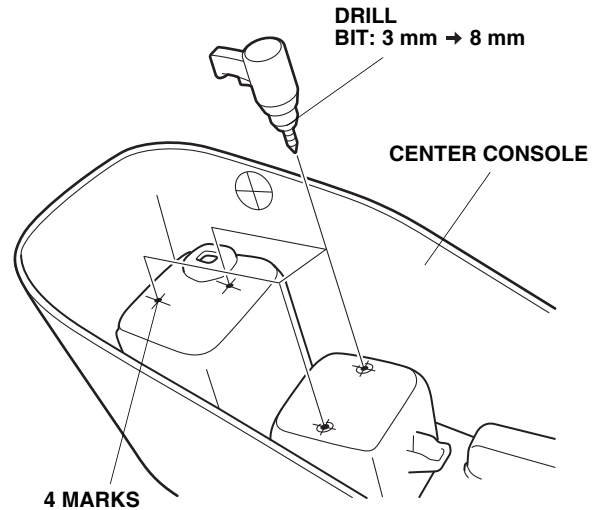

12. While wearing eye protection, drill the two pierced marks on the sides of the center console to 20 mm. First drill with a 3 mm drill bit, and finish with a 20 mm hole saw. Remove any burrs from the edge of the holes with a file.

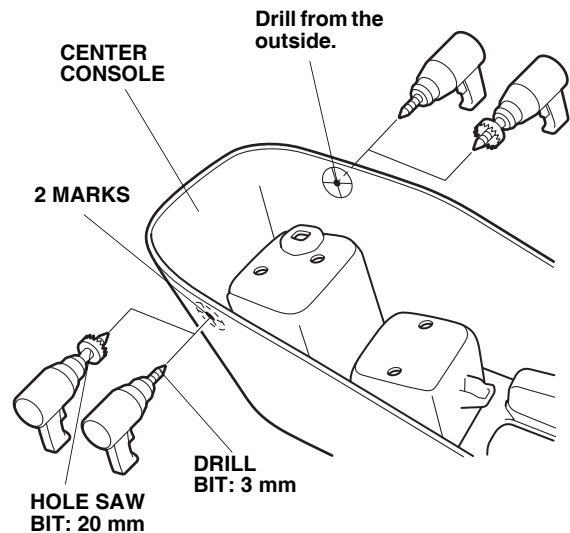

13. Install the armrest console to the center console using two 6 x 25 mm washer-bolts and console bracket.

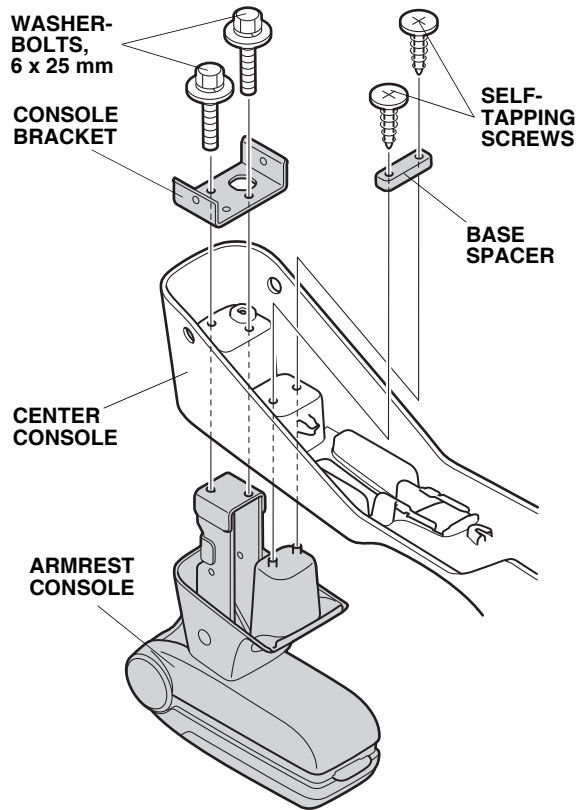

14. Install the base spacer to the armrest console using two self-tapping screws.

15. Remove the pocket from the center console.

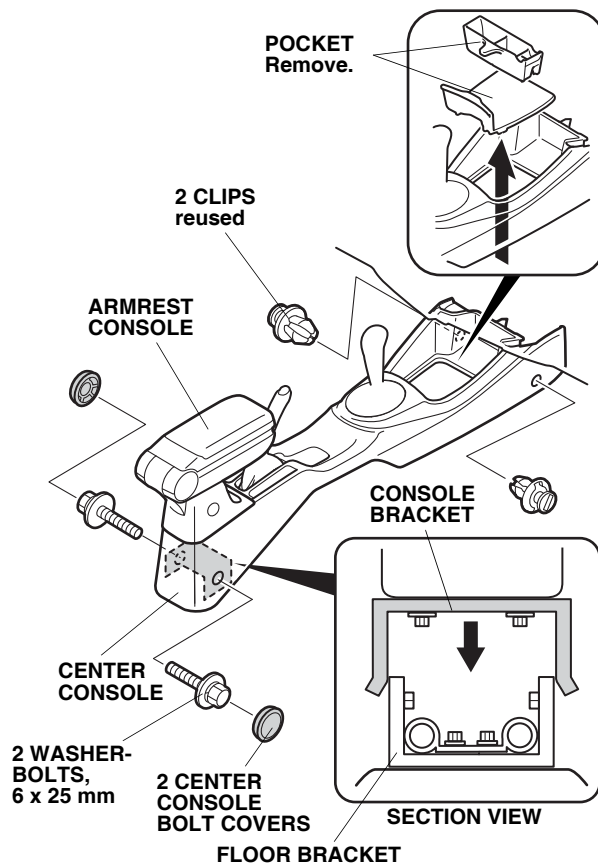

16. Carefully reinstall the center console using the two clips removed in step 7 and the two 6 x 25 mm washer-bolts from the kit.
17. On each side of the center console, install one center console bolt cover to the center console.
18. If equipped, reinstall the shift knob.
19. Reinstall the center console cover and pocket.