



## INSTALLATION INSTRUCTIONS

Accessory  
EXHAUST PIPE FINISHER  
P/N 08F53-TLA-100A

Application  
2020 CR-V

Publications No.  
**VERSION 1**  
Issue Date  
OCT 2019

### PARTS LIST

Exhaust pipe finisher



Washer-bolt



### TOOLS AND SUPPLIES REQUIRED

Ratchet

10 mm Socket

Torque wrench

### *Illustration of the Exhaust Pipe Finisher on the Vehicle*

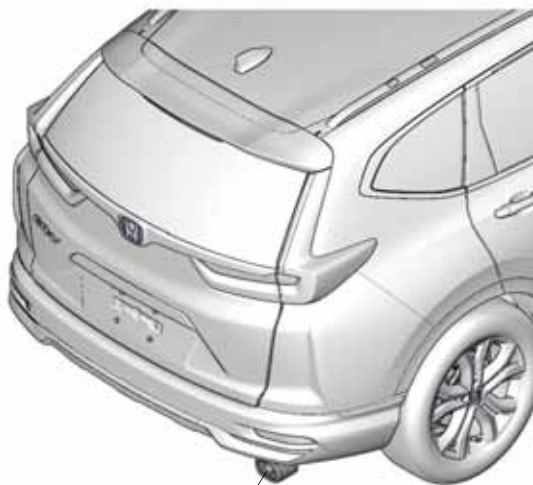

EXHAUST PIPE FINISHER

QHD2401AX

### INSTALLATION

**Customer Information:** The information in this installation instruction is intended for use only by skilled technicians who have the proper tools, equipment, and training to correctly and safely add equipment to your vehicle. These procedures should not be attempted by “do-it-yourselfers.”

#### NOTE:

- Be careful not to damage the vehicle body and the parts of the vehicle.
- The exhaust pipe finisher is designed exclusively for the CR-V; it is not applicable to any other models.
- Allow the exhaust pipe to cool down before installing the exhaust pipe finisher.
- This instruction shows the exhaust pipe finisher being installed on the right exhaust pipe. An additional exhaust pipe finisher (sold separately) can be installed on the left exhaust pipe.

## Installing the Exhaust Pipe Finisher

1. Slide the exhaust pipe finisher in until stops.

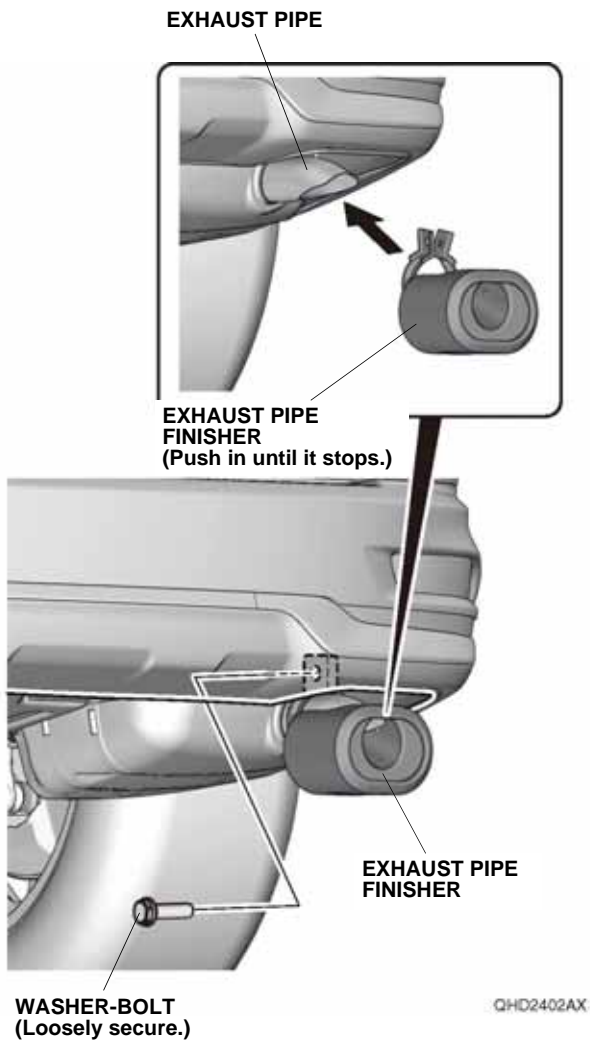

2. Loosely secure the exhaust pipe finisher to the exhaust pipe with one washer-bolt.

3. Adjust the position of the exhaust pipe finisher as shown.

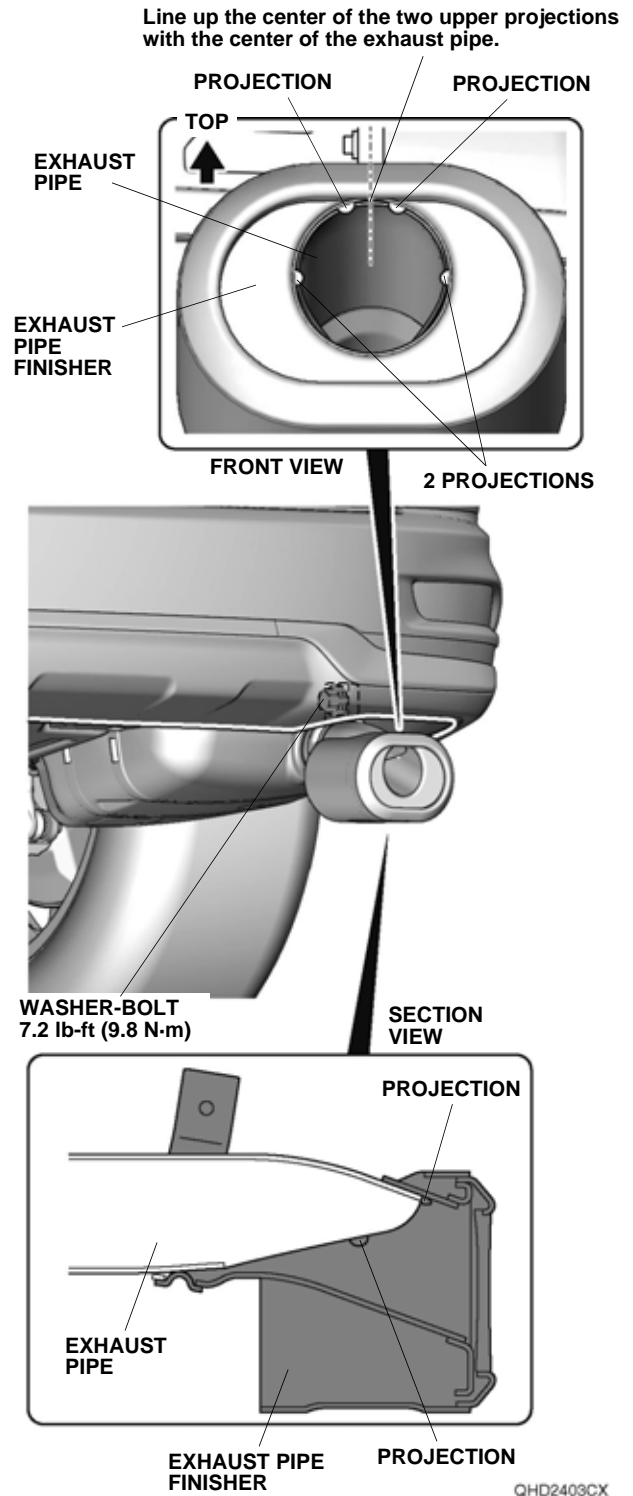

4. While holding the exhaust pipe finisher firmly against the exhaust pipe, tighten the washer-bolt loosely secured in step 2. Torque the washer-bolt to 7.2 lb-ft (9.8 N-m).
5. Start the engine, and rev it up a few times. Listen for vibration from the exhaust pipe finisher, and adjust if necessary.

Give a copy of this page to your customer.

## USE AND CARE

Use a sponge or cloth and a solution of mild liquid dishwashing soap and water to clean the exhaust pipe finisher. Wax the exhaust pipe finisher using Honda Metal Polish (08C20-A021S) or an equivalent. Never use a wax that contains abrasive material as it may scratch the surface.