



INSTALLATION INSTRUCTIONS

Accessory

REAR LOWER TRIM
P/N 08P46-T0A-100A

Application

2014 CR-V

Publications No.

All 50022

Issue Date

JULY 2013

PARTS LIST

Rear lower trim

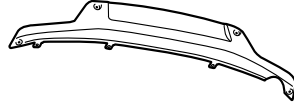

2 Bolts



3 Clips

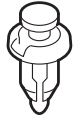

2 Large well nuts



2 Small well nuts

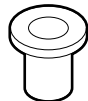

2 Washer-screws



TOOL AND SUPPLIES REQUIRED

Phillips screwdriver

Hex wrench

Drill

3 mm, 5 mm, 8 mm, and 13 mm Drill bits

Pushpin

Eye protection (face shield, safety goggles, etc.)

Ruler

Tape

Utility knife

Torque wrench

Isopropyl alcohol

Shop towel

20 mm Hole saw

The following tools are available through the Honda Tool and Equipment Program. On the iN, click on: Service > Service Bay > Tool and Equipment Program, then enter the number under "Search." Or, call 888-424-6857.

- Air Saw (Snap-on AT192A)
- Plastic trim toll (T/N SILTRIMTL10)
- Rubber roller (T/N MHLE54D)

Illustration of the Rear Lower Trim on the Vehicle

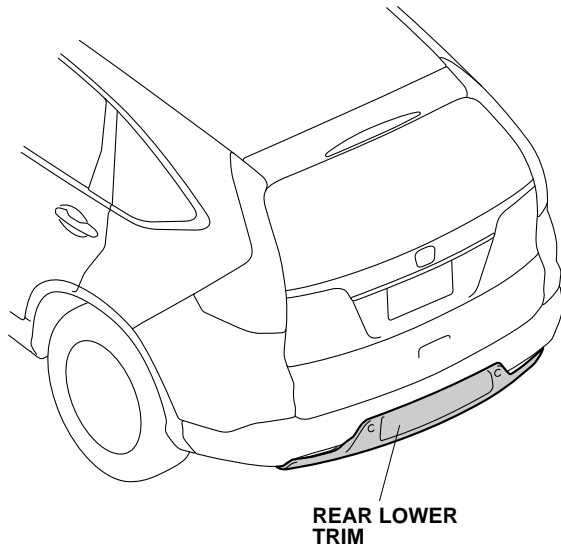

Installing the Rear Lower Trim

1. Remove three clips from the rear splash shield.

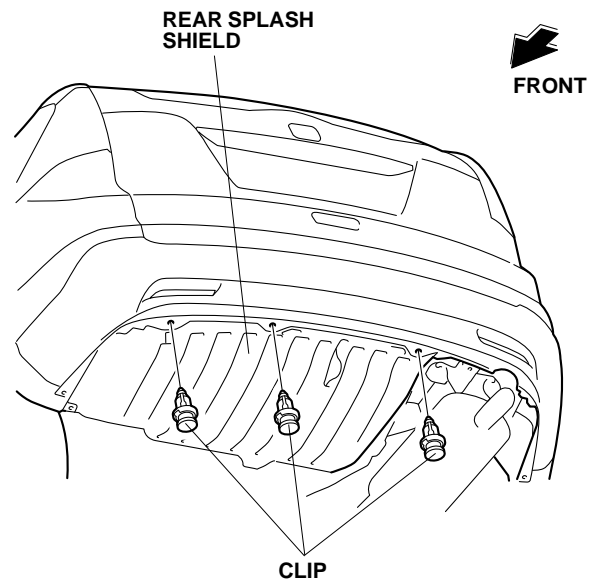

2. Position the rear lower trim on the rear bumper, and loosely secure the rear lower trim with three clips removed in step 1.

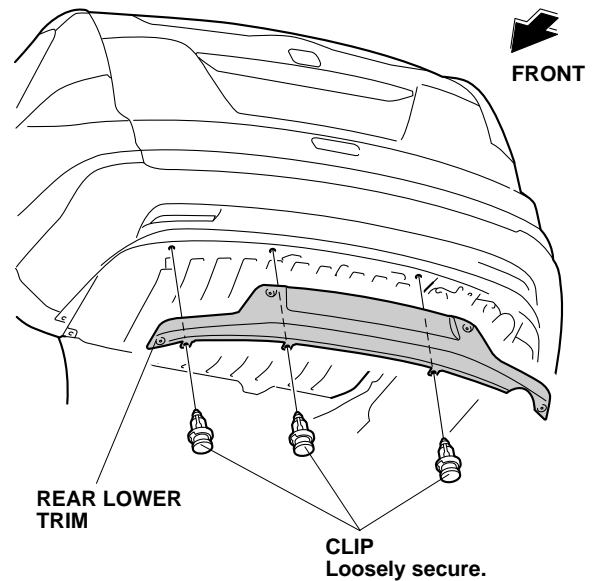

INSTALLATION

Customer Information: The information in this installation instruction is intended for use only by skilled technicians who have the proper tools, equipment, and training to correctly and safely add equipment to your vehicle. These procedures should not be attempted by "do-it-yourselfers."

NOTE:

- Be careful not to damage the vehicle body paint finish.
- This kit should only be installed if the ambient air temperature is 15°C (60°F) or above.
- To allow the adhesive to cure, do not wash the vehicle for 24 hours. Please advise the customer.

3. Using a pushpin, pierce the rear bumper through the four holes in the rear lower trim, then remove the rear lower trim.

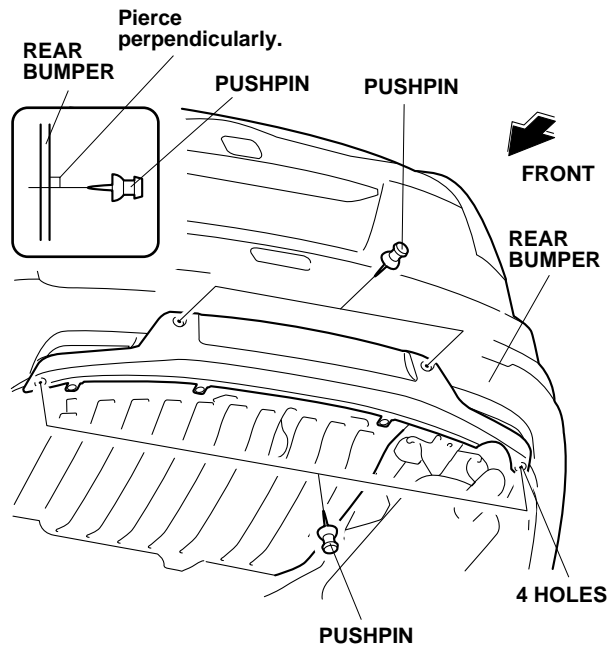

4. While wearing eye protection, drill the two bottom pierced marks to 8 mm:
- Wrap tape around each drill bit 10 mm away from the tip or use a drill stop.
 - First drill with a 3 mm drill bit, then with a 5 mm drill bit, and finish with an 8 mm drill bit.
 - Remove all burrs.

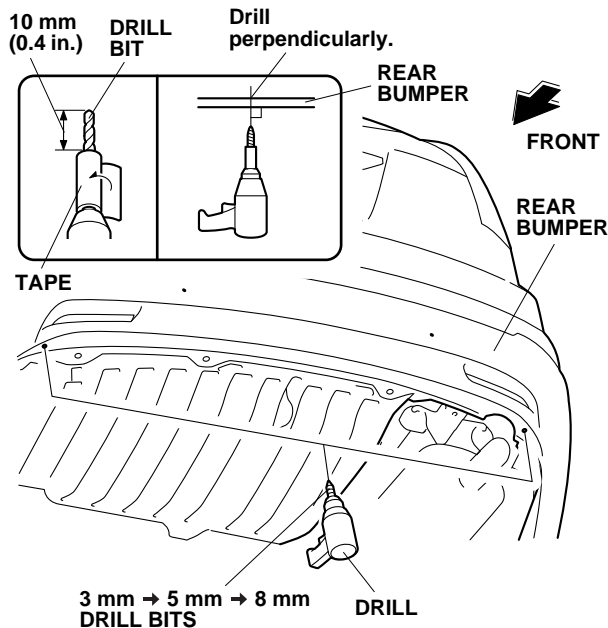

5. While wearing eye protection, drill the two top pierced marks to 13 mm:
- Wrap tape around each drill bit 20 mm away from the tip or use a drill stop.
 - First drill with a 3 mm drill bit, then with a 5 mm drill bit, then with an 8 mm, and finish with a 13 mm drill bit.
 - Remove all burrs.

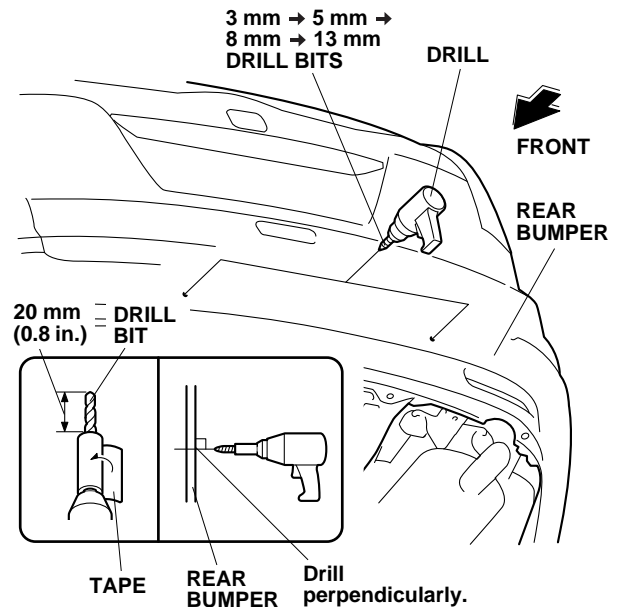

6. Get the rear lower trim. While wearing eye protection, drill the outer holes using a 5 mm drill bit. Remove all burrs.

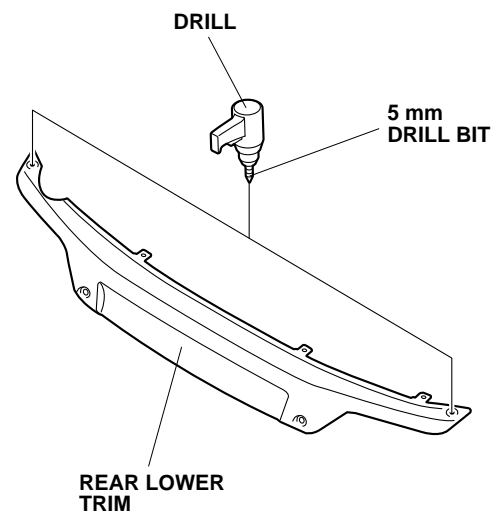

7. While wearing eye protection, drill the lower holes to 8 mm. First drill with a 5 mm drill bit, and finish with an 8 mm drill bit. Remove all burrs.

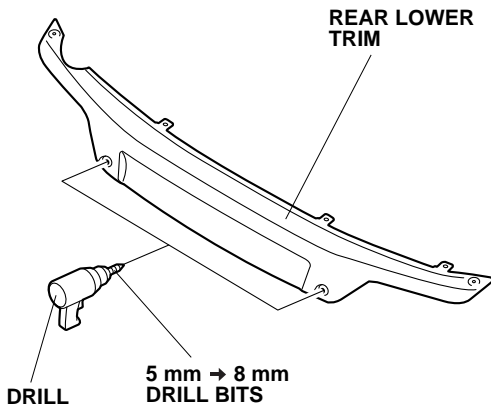

If the vehicle is equipped with the accessory trailer hitch, continue with step 8. Otherwise, go to step 11.

8. Using a pushpin, pierce the rear lower trim at the center of the two scribe marks.

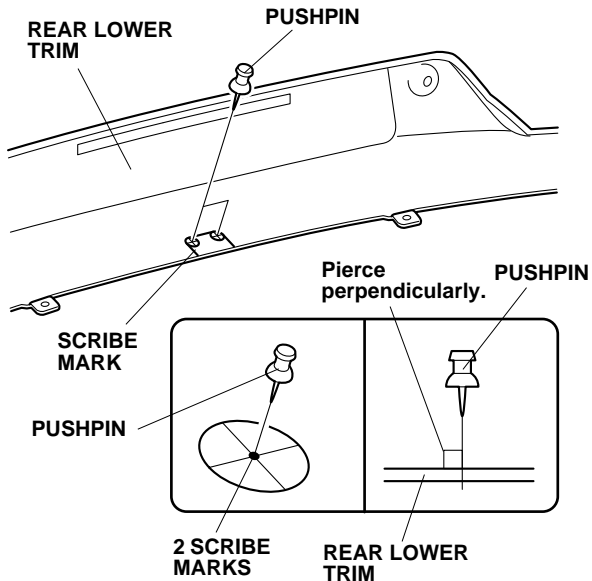

9. While wearing eye protection, drill the two pierced marks to 20 mm. First drill with a 3 mm drill bit, and finish with a 20 mm hole saw.

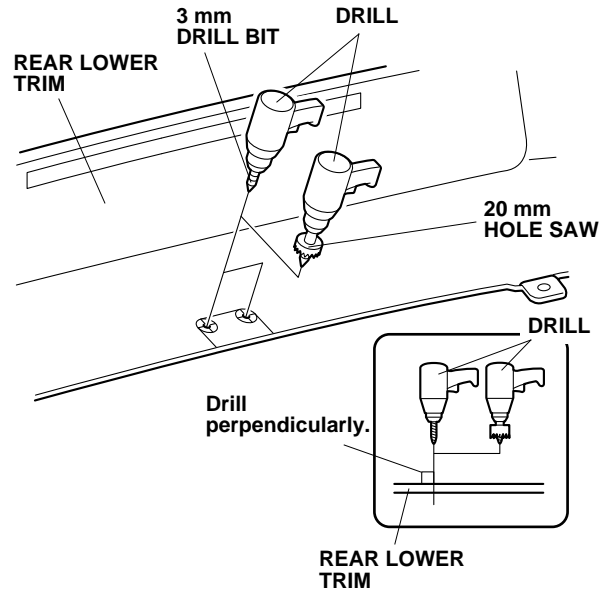

10. Using an air saw, cut off the rear lower trim along the scribe mark. Remove all burrs.

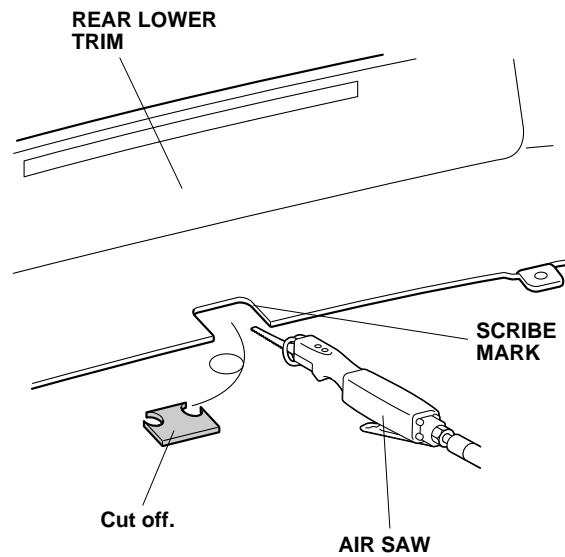

11. Install two large well nuts in the top drilled holes in the bumper, and install two small well nuts in the lower drilled holes.

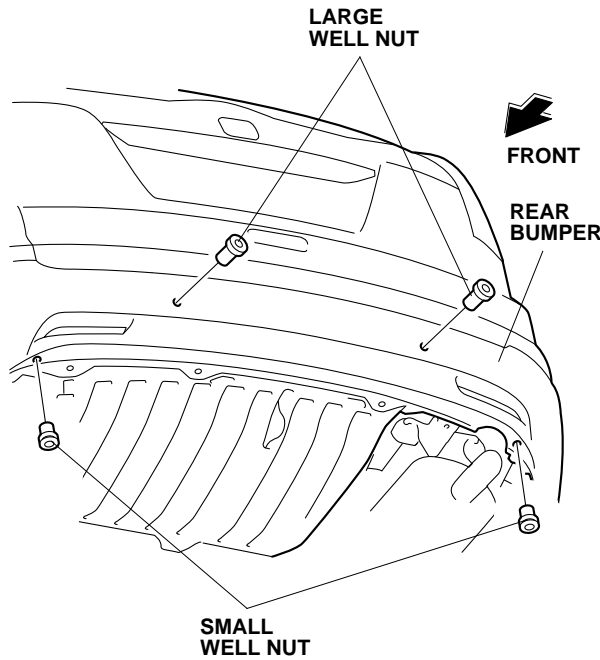

12. Using isopropyl alcohol on a shop towel, thoroughly clean the area where the rear lower trim will attach.

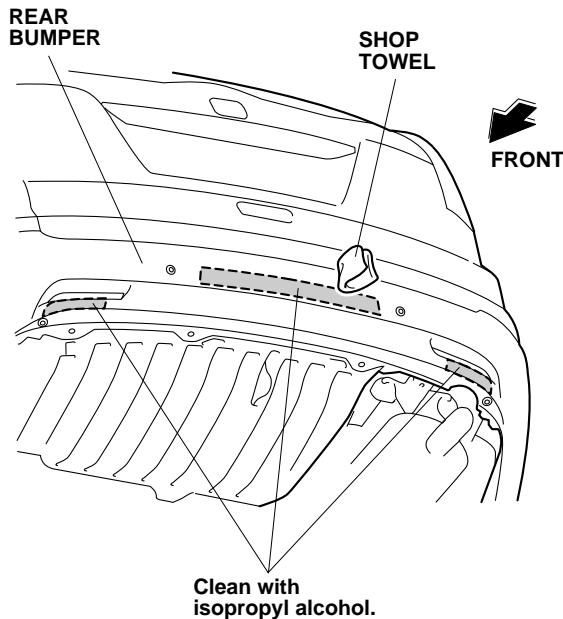

13. Using a utility knife, cut a slit through the center adhesive backing on the rear lower trim.

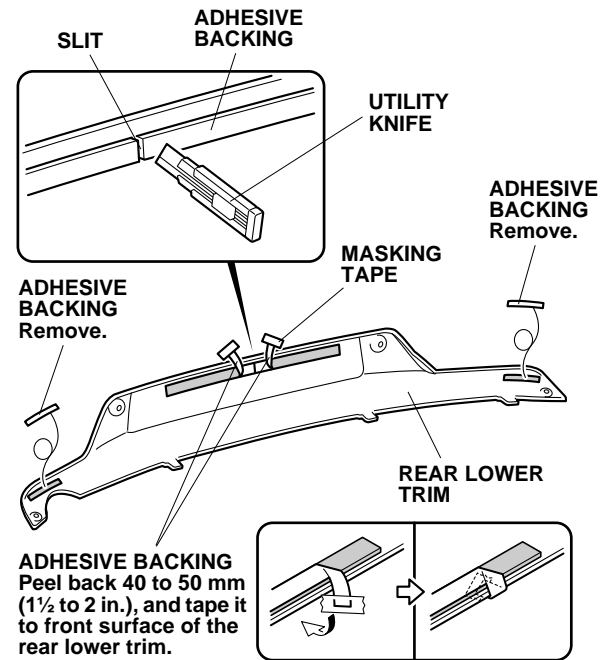

14. Peel back about 40 to 50 mm (1½ to 2 in.) of adhesive backing from each adhesive tape, and tape the ends to the front surface of the rear lower trim. Remove the other adhesive backings.
15. Position the rear lower trim on the rear bumper, and loosely install the rear lower trim with two bolts and two washer-screws.

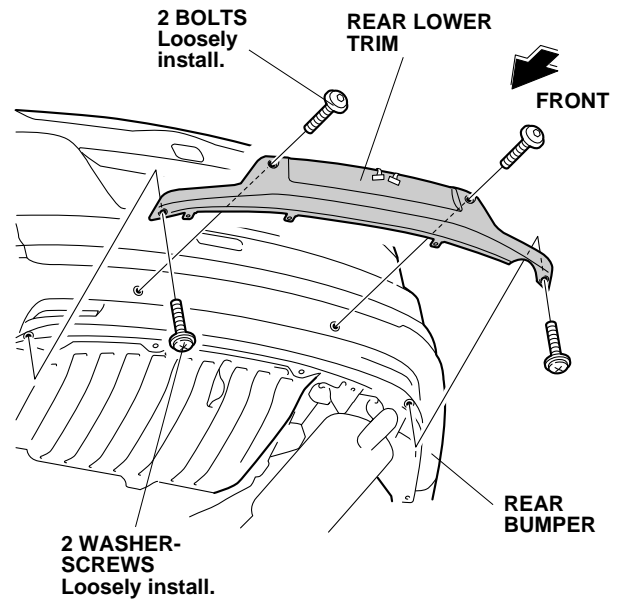

16. While applying light pressure against the rear lower trim, slowly and carefully remove the adhesive backings.

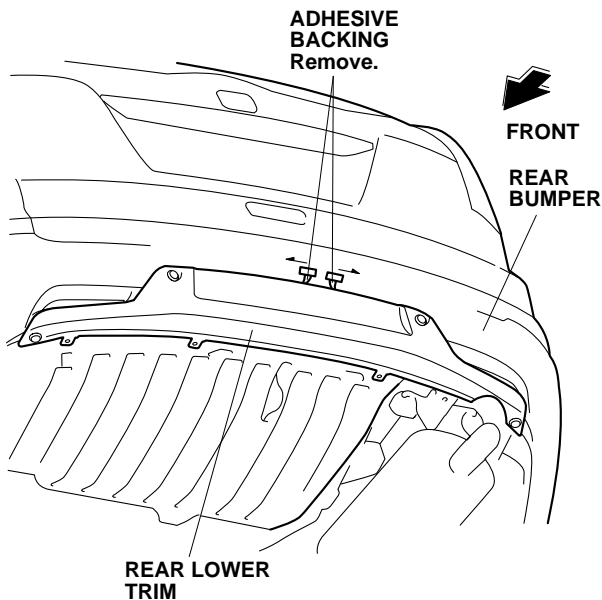

17. Using the palm of your hand, firmly press the rear lower trim against the rear bumper.
18. Using a rubber roller, apply pressure against the top portion of the rear lower trim and roll from one end to the other.

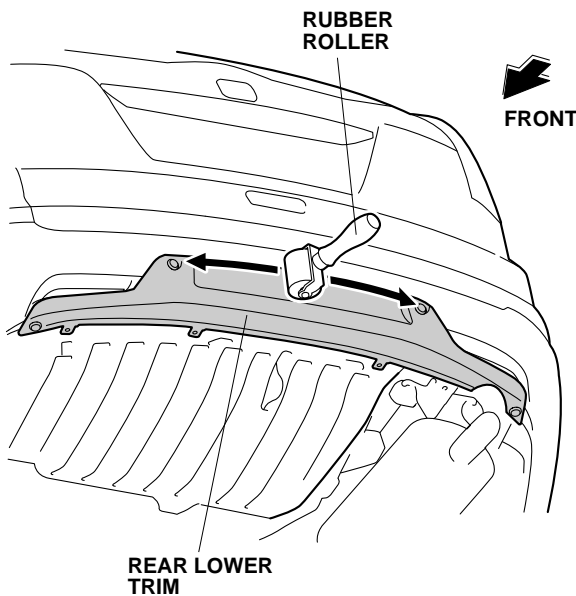

19. Using a rubber roller, apply pressure against the lower portion of the rear lower trim and roll from one end to the other.

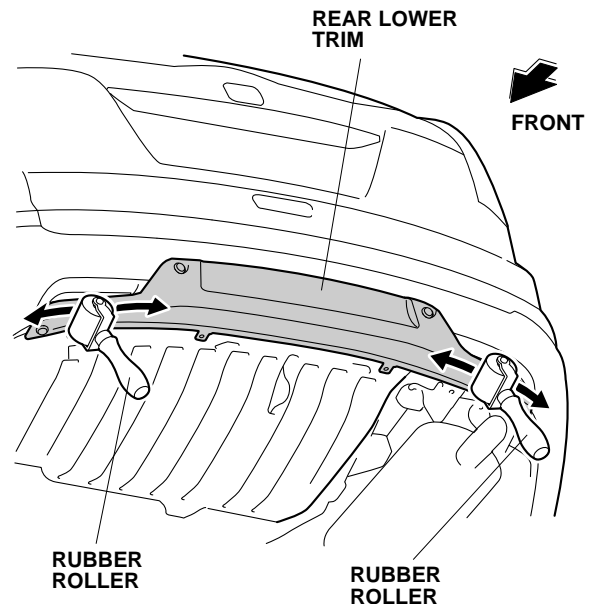

20. Torque the two top bolts to 1.0 N·m (0.7 lbf·ft).

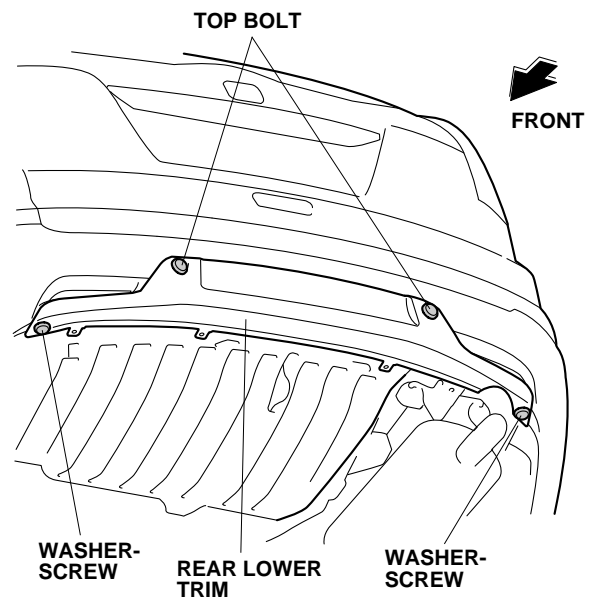

21. Torque the two washer-screws to 0.4 N·m (0.3 lbf·ft).

22. Install the three new clips.

