



## INSTALLATION INSTRUCTIONS

Accessory	Application	Publications No.
SPLASH GUARDS P/N 08P00-TRT-100	2020 CLARITY (All Clarity Vehicles)	VERSION 1
		Issue Date DEC 2019

### PARTS LIST

Left front splash guard



Right front splash guard



Left rear splash guard



Right rear splash guard



4 Washer-self-tapping screws



6 Self-tapping screws



6 Spring nuts



2 Clips



### TOOLS AND SUPPLIES REQUIRED

Phillips screwdriver

Stubby Phillips screwdriver

Pushpin

Diagonal cutters

File

Ruler

Masking Tape

Utility knife

*The following tools are available through the Honda Tool and Equipment Program. On the iN, click on Service > Service Bay > Tool and Equipment Program, then enter the number under "Search." Or, call 888-424-6857.*

Trim Tool Set (T/N SOJATP2014)

### INSTALLATION

**Customer Information:** The information in this installation instruction is intended for use only by skilled technicians who have the proper tools, equipment, and training to correctly and safely add equipment to your vehicle. These procedures should not be attempted by "do-it-yourselfers."

#### NOTE:

- Be careful not to damage the paint finish.
- Clean the areas to be covered.

## Installing the Front Splash Guards

1. Turn the steering wheel fully counterclockwise.

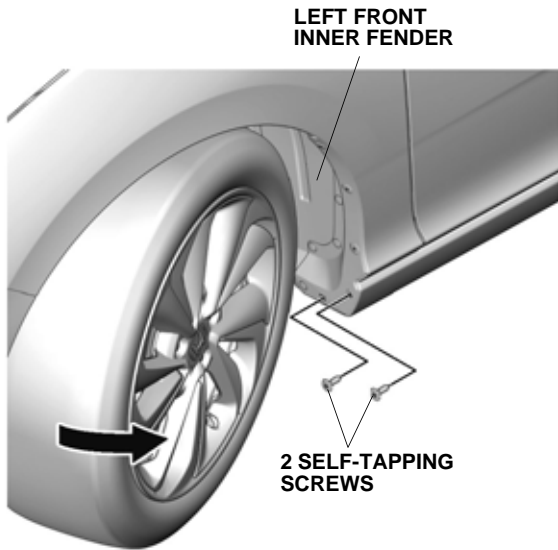

2. Remove two self-tapping screws from the left front inner fender.
3. Using a pushpin, pierce the center of the two clips on the left front inner fender.

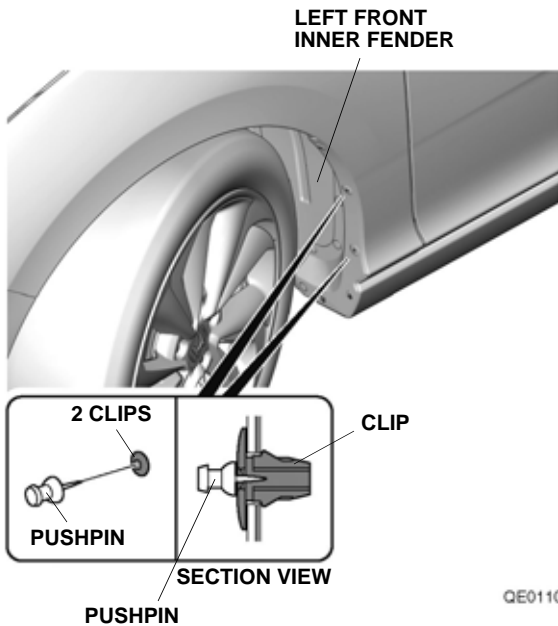

4. Secure the left front splash guard with two washer-self-tapping screws and two self-tapping screws in the order shown below.

NOTE: Make sure there is no gap between the left front splash guard and the vehicle body. If there is a gap, loosen the self-tapping screws, hold the splash guard against the body, and retighten the screws.

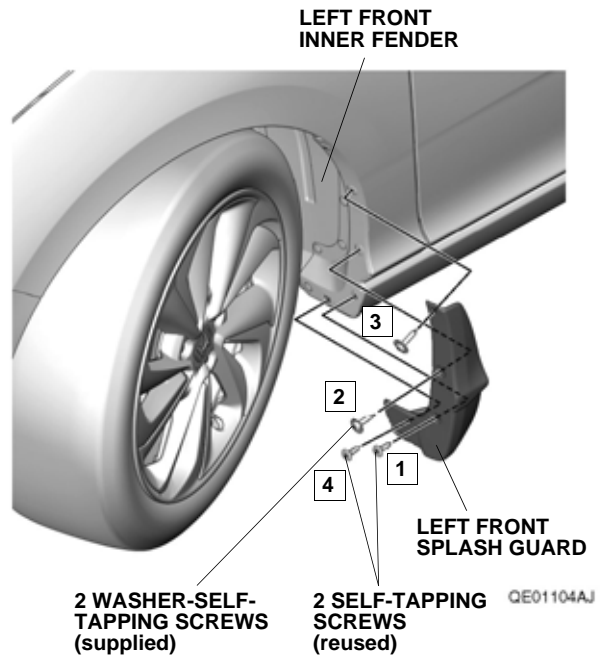

5. Turn the steering wheel fully clockwise, and repeat steps 2 through 4 to install the right front splash guard.

## Installing the Rear Splash Guards

6. Apply masking tape as shown.

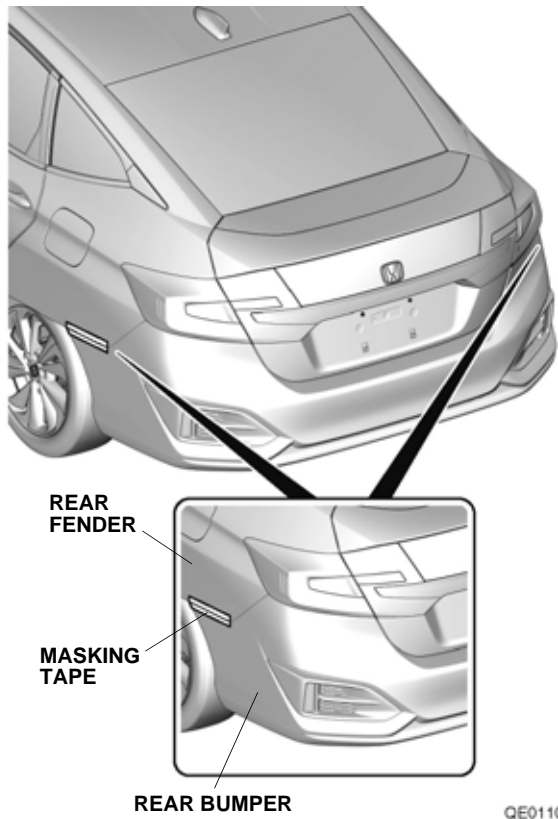

7. Remove the four self-tapping screws and two clips.

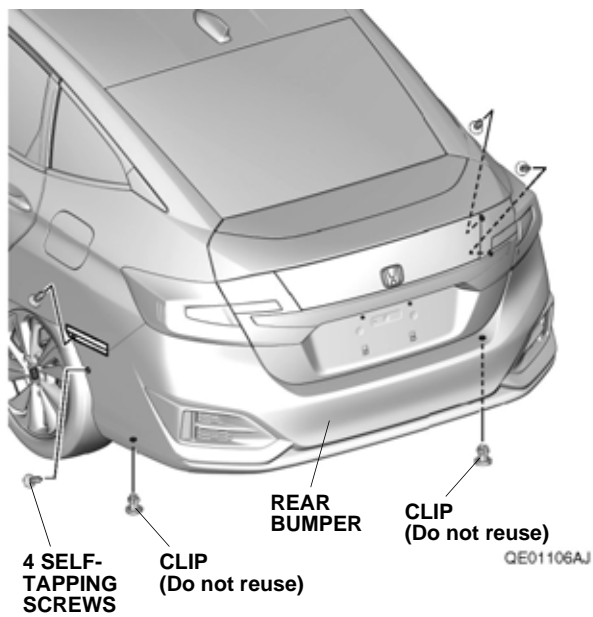

8. Release the three retaining tabs on each side.

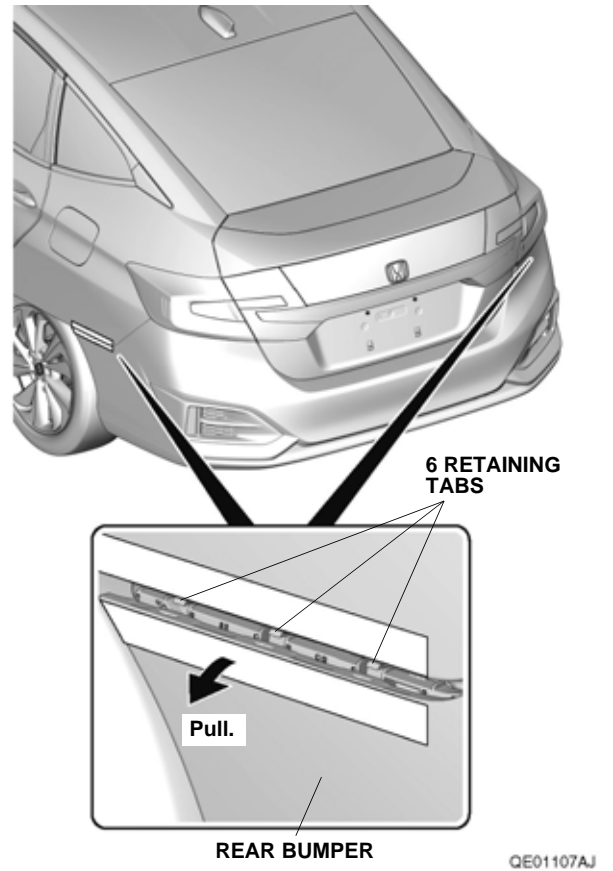

9. Using a utility knife, cut out the left rear inner fender as shown.

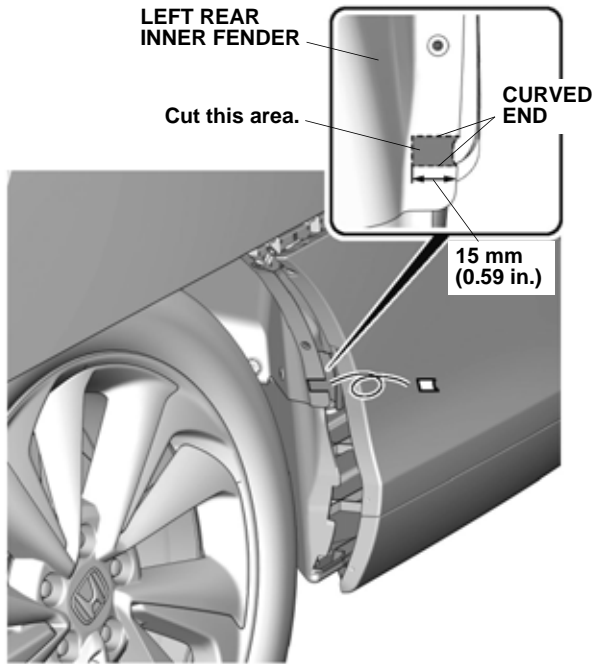

QE01108AJ

10. Remove any burrs with a file.  
 11. Repeat steps 9 and 10 to cut the right rear inner fender.  
 12. Using a utility knife, cut out the right rear under cover as shown.

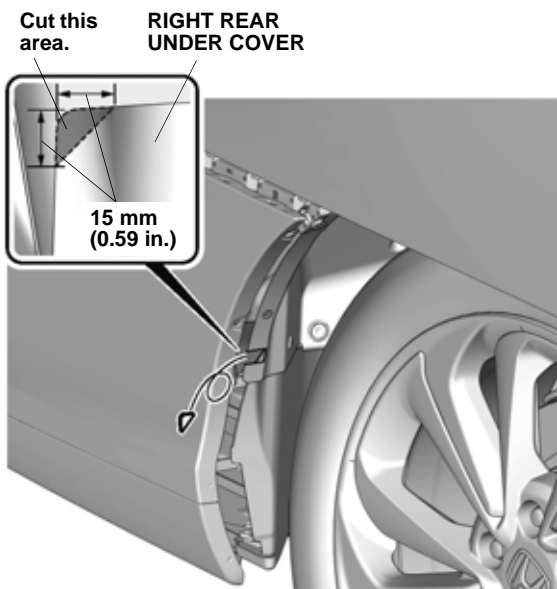

QE01110BJ

13. Remove any burrs with a file.

14. Install the rear bumper with four self-tapping screws.

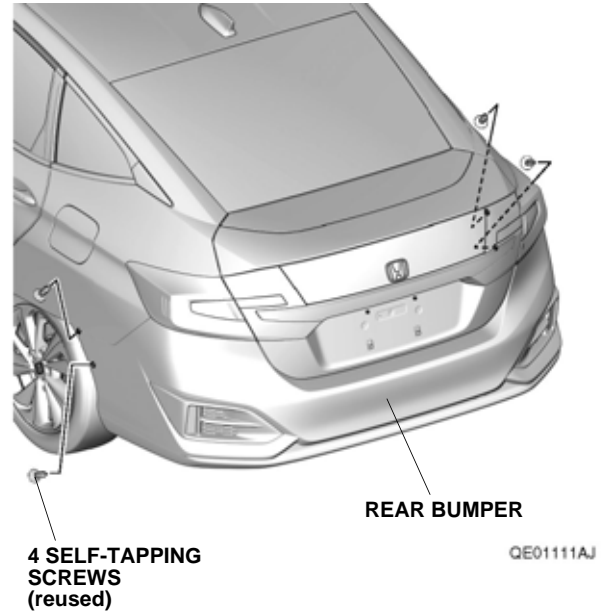

15. Locate the three recessed marks. Using a pushpin, pierce the rear bumper at the three recessed marks.

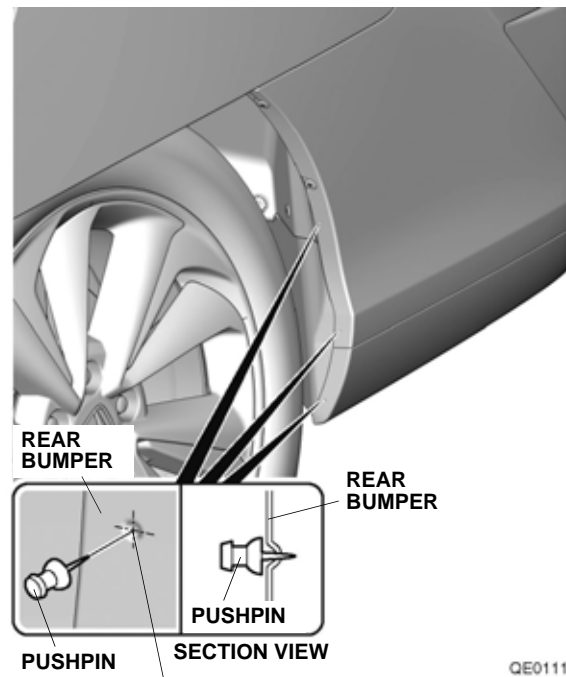

Mark the center of the three recessed marks.

16. Install the three spring nuts on the rear bumper. Make sure to install the spring nuts in the correct position and orientation.

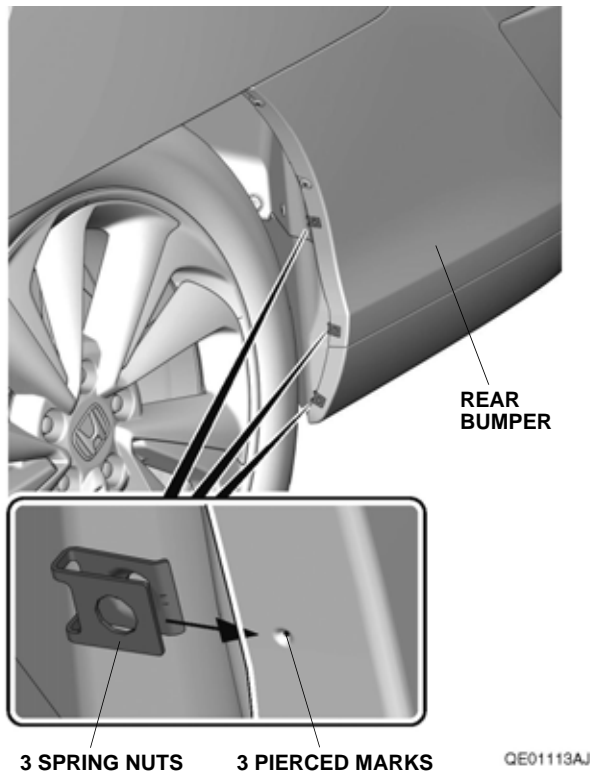

17. Secure the left rear splash guard with three self-tapping screws and one clip in the order shown below.

NOTE: Make sure there is no gap between the left rear splash guard and the bumper. If there is a gap, loosen the self-tapping screws, hold the splash guard against the body, and retighten the screws.

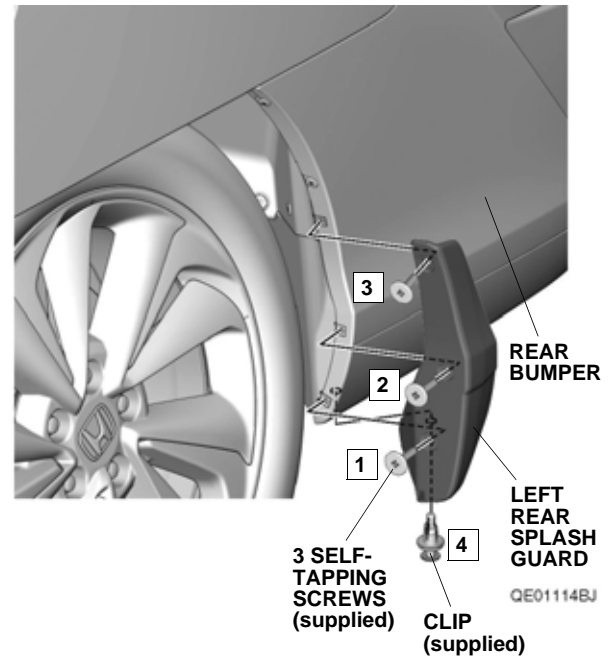

18. Repeat steps 15 through 17 to install the right rear splash guard.