



INSTALLATION INSTRUCTIONS

Accessory

SPLASH GUARDS
P/N 08P00-TGG-100A

Application

2020 CIVIC
5-DOOR SPORT

Publications No.

VERSION 1

Issue Date

AUG 2019

PARTS LIST

Left front splash guard



Right front splash guard



Left rear splash guard



Right rear splash guard



10 Washer-self-tapping screws



2 Self-tapping screws



2 Brackets



2 Washers



Template



TOOLS AND SUPPLIES REQUIRED

Phillips screwdriver

Stubby Phillips screwdriver

Pushpin

Drill

3 mm and 6 mm Drill bits

File

Eye protection (face shield, safety goggles, etc.)

Utility knife

Masking tape

Felt-tip pen

The following tools are available through the Honda Tool and Equipment Program. On the iN, click on Service > Service Bay > Tool and Equipment Program, then enter the number under "Search." Or, call 888-424-6857.

- Trim Tool Set (T/N SOJATP2014)
- Plastic Trim Tool (T/N SILTRIMTL10)
- Deburring Tool (T/N DEBUR300)

INSTALLATION

Customer Information: The information in this installation instruction is intended for use only by skilled technicians who have the proper tools, equipment, and training to correctly and safely add equipment to your vehicle. These procedures should not be attempted by “do-it-yourselfers.”

NOTE:

- Be careful not to damage the paint finish.
- Clean the areas to be covered.

Installing the Front Splash Guards

1. Turn the steering wheel fully counterclockwise.

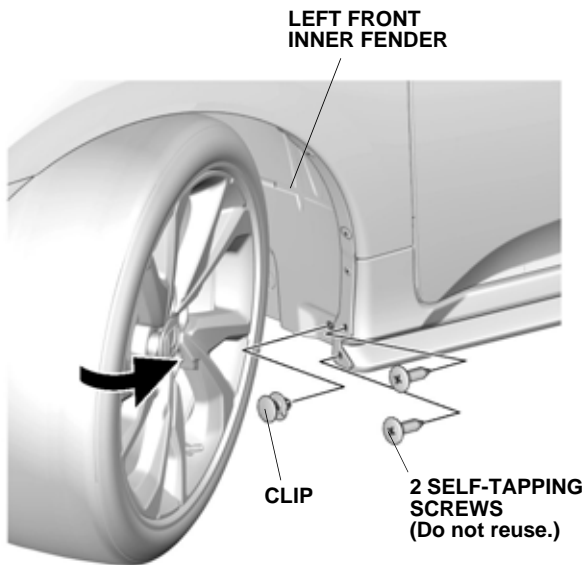

QG21302BT

2. Remove the two self-tapping screws and one clip from the left front inner fender.

3. Using a pushpin, pierce the center of the clip on the left front inner fender.

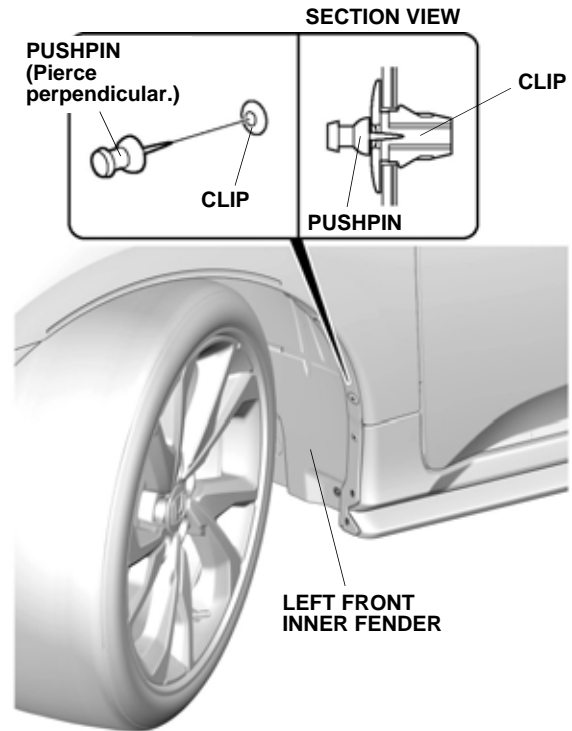

QG21303BT

4. Secure the left front splash guard with three washer-self-tapping screws and one clip in the order shown below.

NOTE: Make sure there is no gap between the left front splash guard and the vehicle body. If there is a gap, loosen the washer-self-tapping screws, hold the splash guard against the body, and retighten the screws.

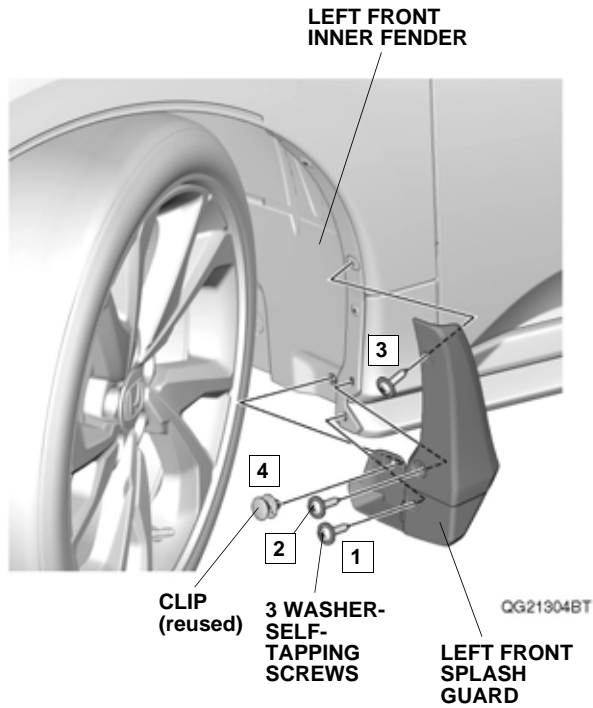

Installing the Rear Splash Guards

5. Line up the template to the rear bumper as shown, and attach it with masking tape.

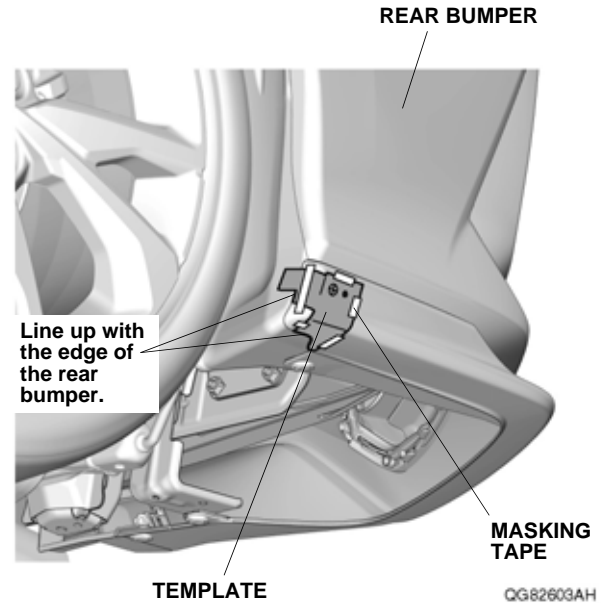

6. Using a felt-tip pen, mark the left rear inner fender along the template.

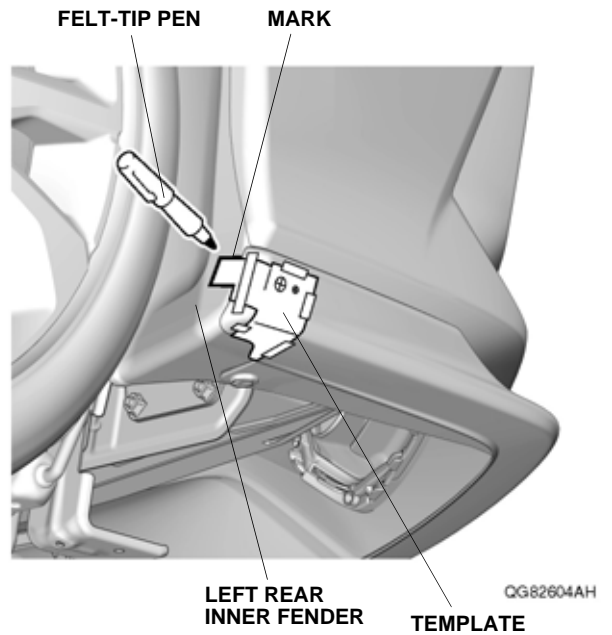

7. Using a pushpin, pierce the center of the two marks on the template.

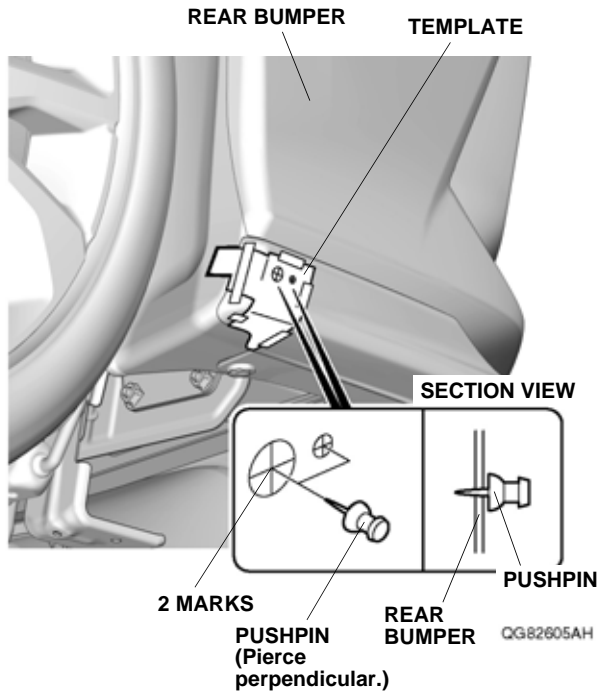

8. Remove the template.

9. While wearing eye protection, drill the rear pierced mark with a 3 mm drill bit.

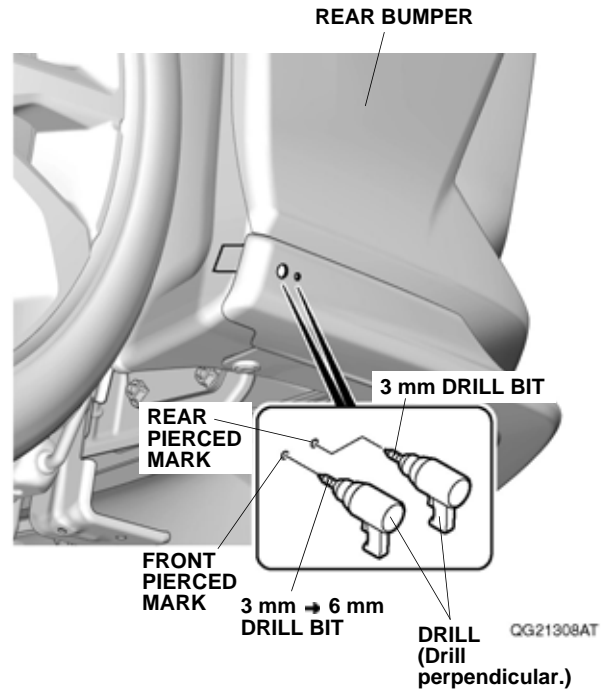

10. While wearing eye protection, drill the front pierced mark with a 3 mm drill bit, then finish with a 6 mm drill bit.
11. Using a deburring tool, remove any burrs from the holes.
12. Remove one self-tapping screw and one clip from the rear bumper.

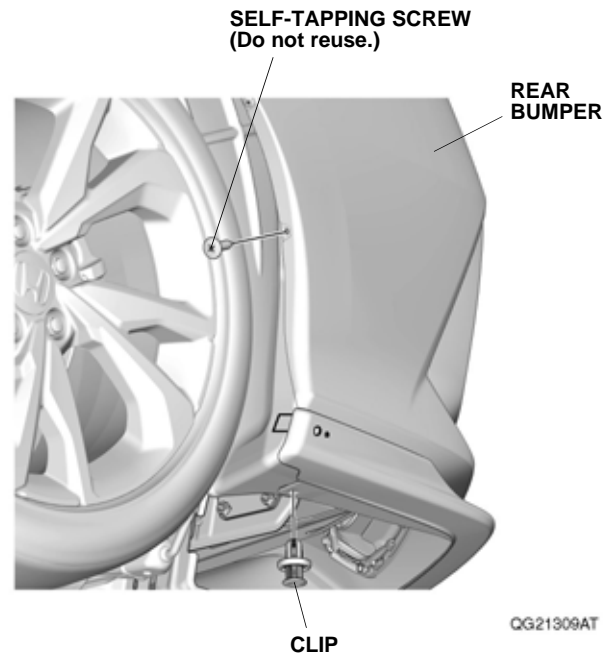

13. Using a felt-tip pen, mark the left rear inner fender as shown.

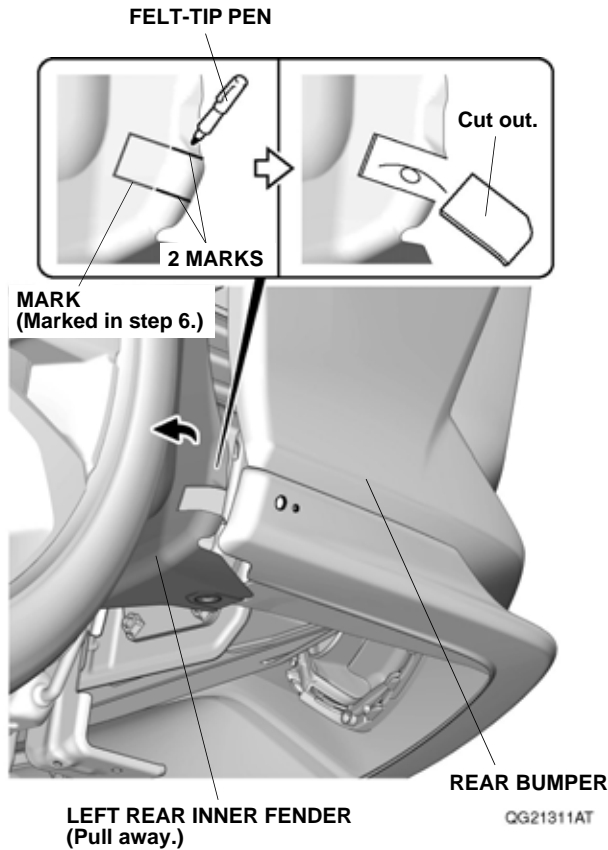

14. Using a utility knife, cut out the left rear inner fender along the marks.
15. Secure the bracket to the rear bumper with one self-tapping screw and one washer.

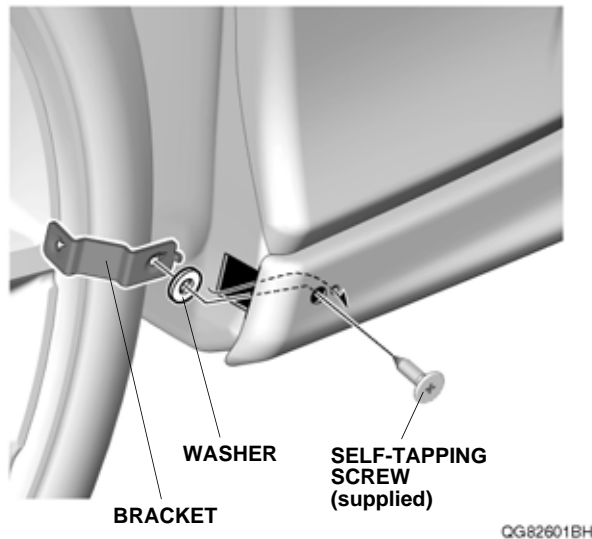

16. Secure the left rear splash guard with two washer-self-tapping screws in the order shown below. NOTE: Make sure there is no gap between the left rear splash guard and the bumper. If there is a gap, loosen the washer-self-tapping screws, hold the splash guard against the bumper, and retighten the screws.

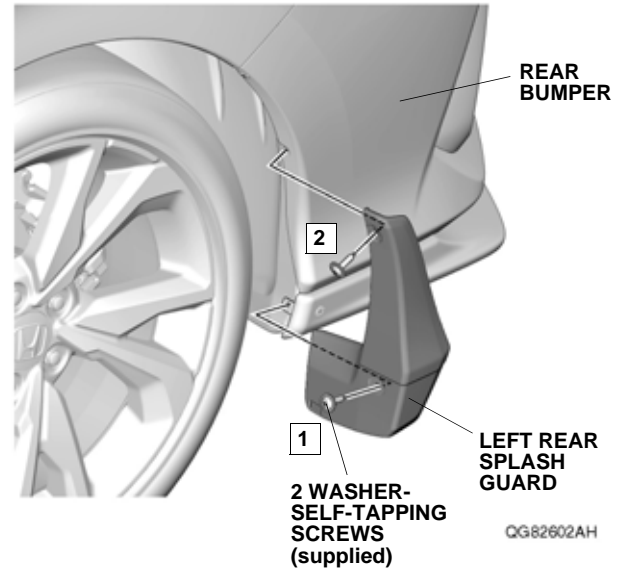

17. Secure the left rear splash guard with one clip.

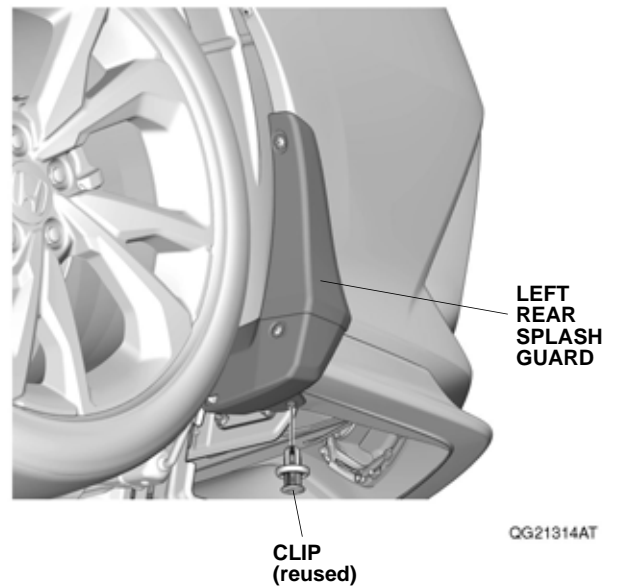

18. Turn the steering wheel fully clockwise. Turn the template over and repeat steps 2 through 17 to install the right splash guards.