



INSTALLATION INSTRUCTIONS

Accessory
16" ALUMINUM WHEEL
 P/N 08W16-TR0-100

Application
2014 CIVIC
2 AND 4-DOOR

Publications No.
All 50675

Issue Date
NOV 2013

PARTS LIST

Aluminum wheel
 (The illustration may differ from the actual wheel.)

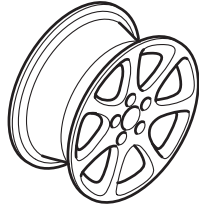

Wheel center cap



Tire and loading information label
 (May not used)

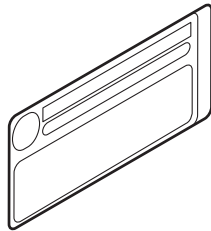

TPMS Information
 (Give this to your customer.)

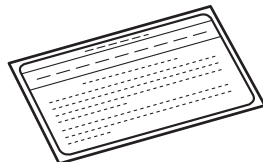

Supplemental Information
 (May not used)

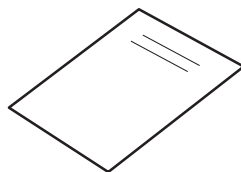

Parts for TPMS sensor assembly

Tire pressure sensor assembly

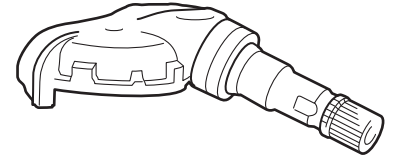

Washer



Valve nut

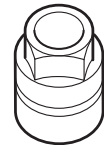

TOOLS AND SUPPLIES REQUIRED

- Ratchet
- 11 mm Socket
- Torque wrench
- Isopropyl alcohol
- Shop towel
- HDS
- TPMS Trigger Tool ATEQ VT55 (T/N AEQVT55)
 (Available through the American Honda Tool and Equipment Program: call 888-424-6857)

SPECIFICATIONS

Rim size	16 x 6 1/2 J (inset 45)	
Tire size	P205/55R16 89H	
Bolt hole PCD	114.3 (5 holes)	
Tire pressure	Front	220kPa (2.2 kgf/cm ² , 32 psi)
	Rear	220kPa (2.2 kgf/cm ² , 32 psi)

INSTALLATION

Customer Information: The information in this installation instruction is intended for use only by skilled technicians who have the proper tools, equipment, and training to correctly and safely add equipment to your vehicle. These procedures should not be attempted by “do-it-yourselfers.”

NOTE:

- This aluminum wheel is designed for use on a vehicle equipped with TPMS (Tire Pressure Monitoring System).
- This aluminum wheel is equipped with a TPMS sensor. See the service manual for the tire replacement procedure and TPMS sensor installation procedure.
- The illustrations of the aluminum wheels are shown for reference purposes only.
- Install the correct size tire.
- Follow the instructions in the owner’s manual when jacking up the vehicle and removing and installing the wheels. Do not overtighten the wheel nuts.

Wheel nut torque: 108 N·m (11 kgf·m, 80 lbf·ft).

- Use a tire changer to install and remove the tires as described in the Operation Manual furnished with the tire changer. Do not use a tire lever to install and remove the tires as it may damage the tire and the aluminum wheel.

1. Before installing the tire pressure sensor, clean the mating surface on the sensor and the aluminum wheel.

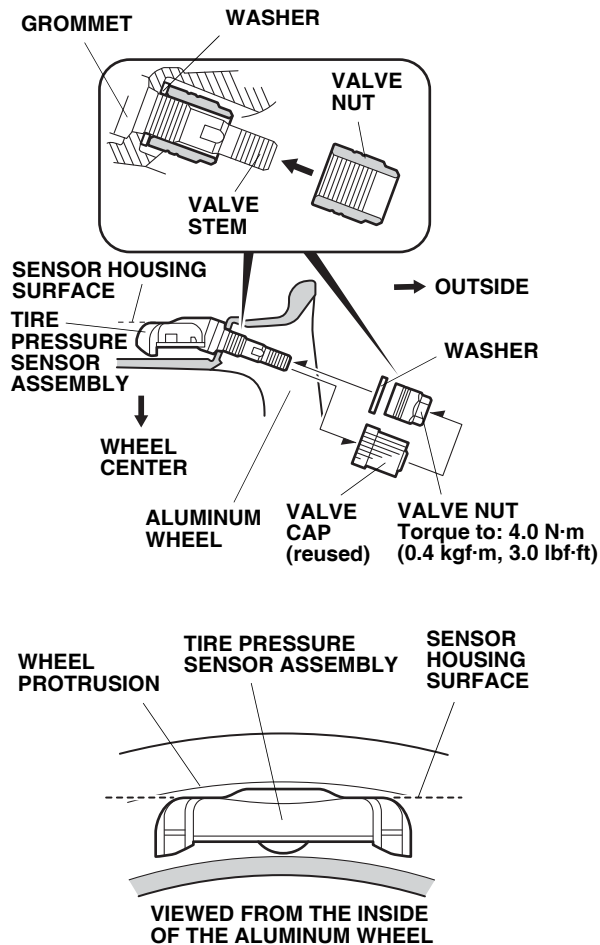

2. Remove the valve cap. Install the tire pressure sensor assembly and the washer onto the aluminum wheel, and finger tighten the valve nut. Make sure the tire pressure sensor assembly is resting on the wheel.
 3. Tighten the valve nut to the specified torque while holding the tire pressure sensor assembly against the wheel. Reinstall the valve cap.
Valve nut torque: 4.0 N·m (0.4 kgf·m, 3.0 lbf·ft).
- NOTE:** Install the tire pressure sensor assembly so that the sensor housing surface does not protrude into the bead area of the wheel.
4. Install the tires according to the instructions in the service manual.
 5. Install the wheels on the vehicle and torque the wheel nuts to 108 N·m (11 kgf·m, 80 lbf·ft).

USE AND CARE

- Use a neutral detergent to clean the wheels.
- Rinse off the detergent promptly after cleaning the wheel.

MEMORIZING THE TIRE PRESSURE SENSOR ID

Models equipped with standard 16" wheels.

The accessory tire and loading information label and the Supplemental Information are not used.

1. Using the HDS and TPMS trigger tool, memorize the tire pressure sensor ID according to the instructions in the service manual (Memorizing the Tire Pressure Sensor ID).

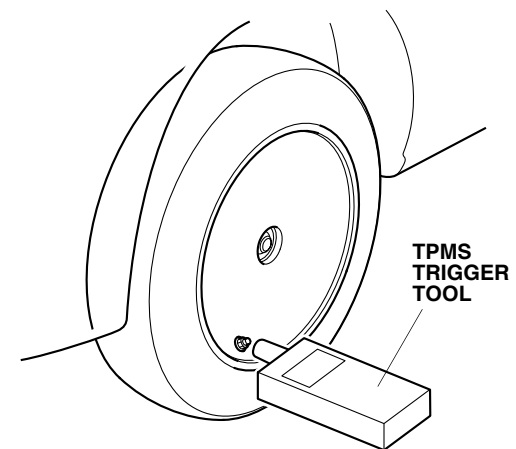
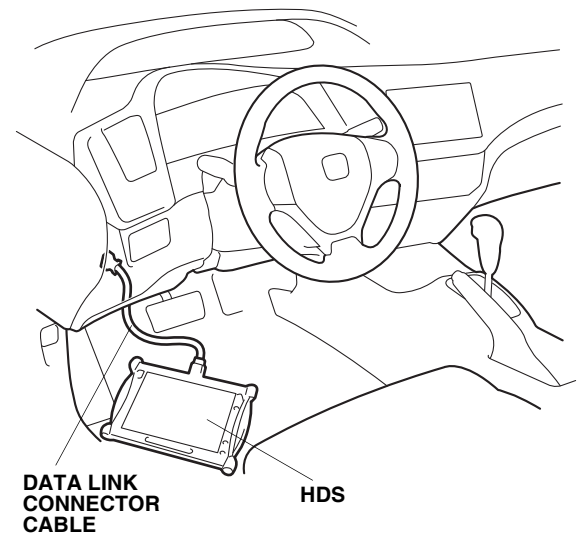

If this model was not originally equipped with 16" wheels, do steps 2 through 6.

2. Open the driver's door. Using isopropyl alcohol on a shop towel, thoroughly clean the area where the accessory tire and loading information label will attach. Remove the adhesive backing from the accessory tire and loading information label, and attach it over the standard tire and loading information label.

4-door vehicle:

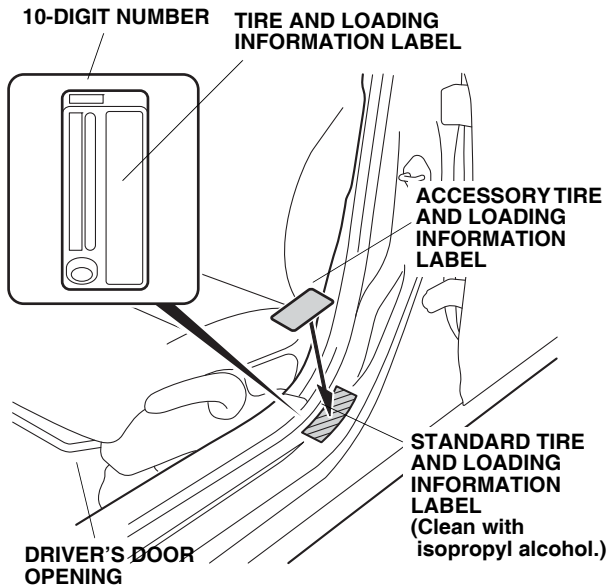

2-door vehicle:

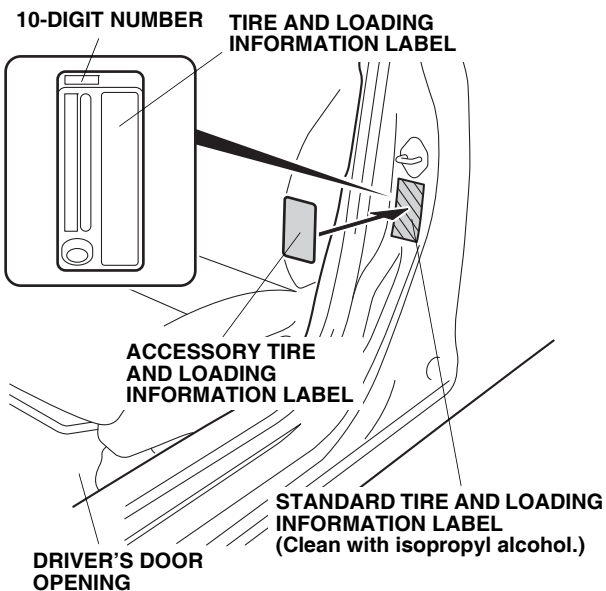

3. Attach the "Supplemental Information" page included in this kit into the owner's manual.
4. Using the HDS and TPMS trigger tool, memorize the tire pressure sensor ID according to the instructions in the service manual (Memorizing the Tire Pressure Sensor ID).
5. Perform the Inch-up Tire Pressure programming procedure.
6. After finishing the work, write the tire size, tire pressure, HDS version, dealer name, technician's signature and date on the "Service History Page for Honda Accessory Alloy Wheels" page included in this kit and attach it to the vehicle's service history booklet.

INCH-UP TIRE PRESSURE PROGRAMMING (LOW AIR PRESSURE WARNING THRESHOLD REPROGRAMMING)

1. After doing the sensor ID learning using the HDS, back up to the “TPMS Mode Menu,” and click on “Threshold Rewriting.”
2. Select “Reprogramming for accessory tires.”
3. When the HDS says, “Do you want to rewrite the threshold data?” click “YES.”
4. Check that “Please enter the tire information code of new tires” is shown, and click the “Keyboard” icon.
5. Enter the 10-digit tire information code printed on the new tire and loading information label, then click the check icon.
6. Check that the tire pressure shown on the HDS and the new tire pressure on the tire and loading information label are the same, then click the “YES” button.
7. Check that the current air pressure setting shown on the HDS is correct and “Reprogramming the threshold data for non-standard tires has completed successfully” is shown.
8. After programming, write the tire pressure indicated on the HDS on the “Service History Page for Honda Accessory Alloy Wheels,” then click the check icon.
9. After programming, sign on the “Service History Page for Honda Accessory Alloy Wheels.”

- Explain the contents of the “Supplemental Information” when delivering the vehicle to your customer.
- Give the TPMS information to your customer.

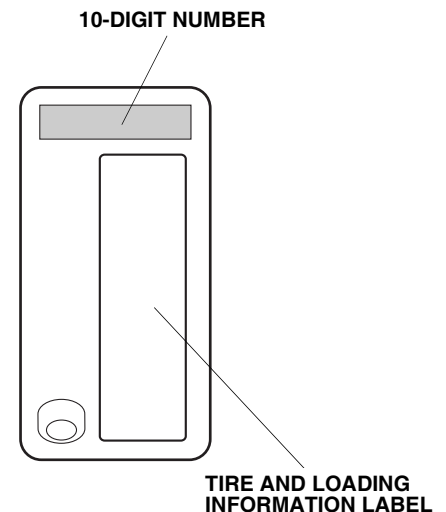
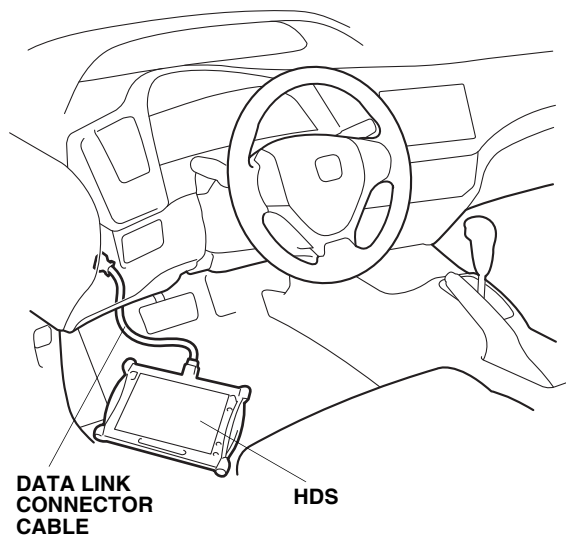

STANDARD TIRE PRESSURE PROGRAMMING

If the original equipment (standard) tires are to be installed back on the vehicle, memorize the tire pressure sensor ID and change the low pressure warning threshold.

NOTE: Reapply a factory standard tire and loading information label to the vehicle.

1. Install the standard tires, and memorize the tire pressure sensor IDs according to the instructions in the service manual.
2. Change the tire pressure programming (the low air pressure warning threshold):
 1. Connect the HDS to the vehicle, make sure the correct VIN is populated, and enter the mileage.
 2. At the "System Selection Menu," click "TPMS."
 3. At the "Mode Menu," click on "DTCs" and clear any stored codes.
 4. Go back to the "Mode Menu," and click on "Threshold Rewriting."
 5. Click on "Reprogramming for standard tires," and follow the screen prompts.
 6. After programming, write the standard tire pressure in the supplemental information, then click the check button.
 7. Attach the tire and loading information label for standard tires to the door jamb.
 8. After programming, write the tire size, tire pressure, HDS version, dealer name, date, and technician signature in the "Service History Page for Honda Accessory Alloy Wheels."

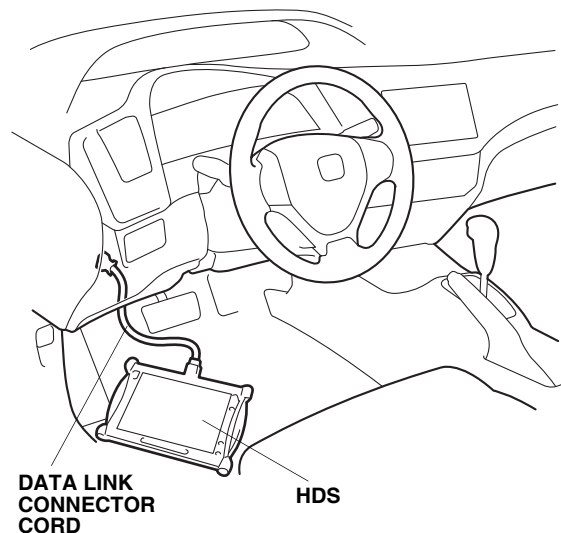

THRESHOLD DATA CHECK

If for some reason you are unsure of where the low pressure warning threshold is set, it can be checked by using the Threshold Data Check.

1. Connect the HDS to the vehicle, make sure the correct VIN is populated, and enter the mileage.
2. At the "System Selection Menu," click "TPMS."
3. Click on "Threshold Rewriting."
4. Click on "Threshold Data Check."

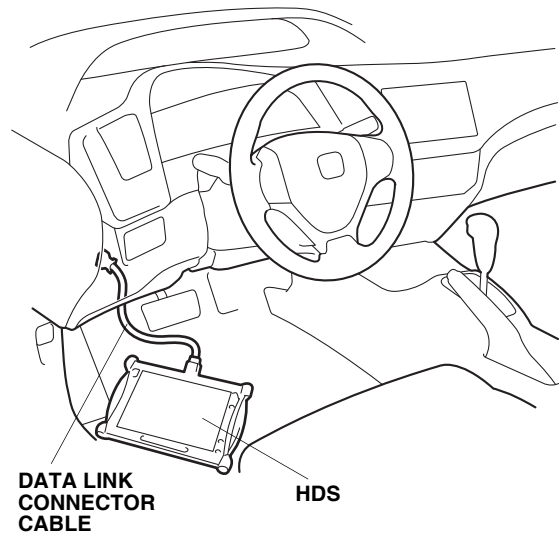

TPMS Control Unit Replacement

If the TPMS control unit is ever replaced and the vehicle has inch-up wheels, the low pressure sensor threshold must be changed. Once the TPMS control unit is installed, follow steps 1 to 6 (which includes memorizing ID and programming for accessory tires).