



INSTALLATION INSTRUCTIONS

Accessory
FRONT UNDER SPOILERS
 P/N 08F01-T3L-100

Application
2014 ACCORD
2-DOOR

Publications No.
All 49942

Issue Date
AUG 2013

PARTS LIST

Right front under spoiler

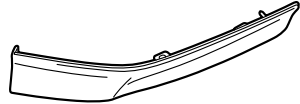

Left front under spoiler

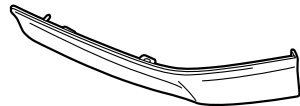

Template

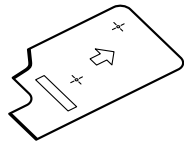

2 Clips

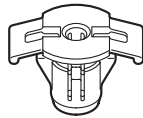

2 Bumper clips

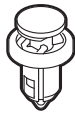

4 Self-tapping screws



4 Spring nuts



2 Washers



Spacer

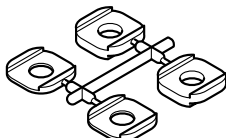

2 Alcohol swabs

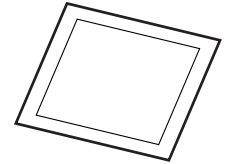

TOOLS AND SUPPLIES REQUIRED

Phillips screwdriver

Drill

3 mm, 10 mm, and 12 mm Drill bits

Eye protection (face shield, safety goggles, etc.)

File

Electrical tape

Masking tape

Diagonal cutters

Ruler

Pushpin

The following tools are available through the Honda Tool and Equipment Program. On the iN, click on: Service > Service Bay > Tool and Equipment Program, then enter the number under "Search". Or, call 888-424-6857.

- Rubber Roller (T/N MHLE540)
- Trim Tool Set (T/N SOJATP2014)

Illustration of the Front Under Spoilers on the Vehicle

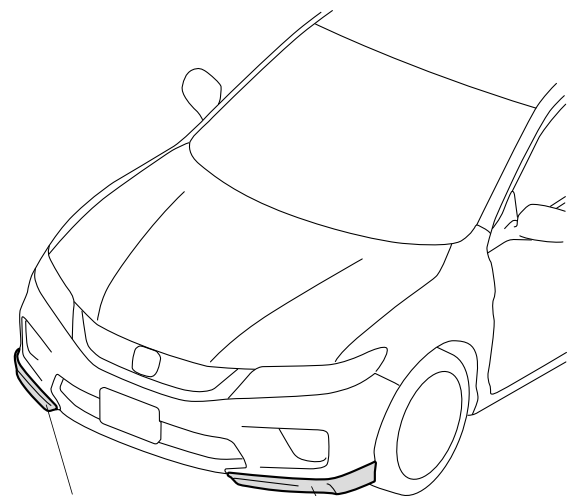

RIGHT FRONT UNDER SPOILER

LEFT FRONT UNDER SPOILER

QB40303AE

INSTALLATION

Customer Information: The information in this installation instruction is intended for use only by skilled technicians who have the proper tools, equipment, and training to correctly and safely add equipment to your vehicle. These procedures should not be attempted by "do-it-yourselfers."

NOTE:

- Be careful not to damage the paint finish.
- This kit should be installed only if the ambient air temperature is 15°C (60°F) or above.
- Clean and wax the areas to be covered with a high-quality paste wax.
- To allow the adhesive to cure, do not wash the vehicle for 24 hours. Please advise the customer.

1. Remove the two clips from the front bumper.

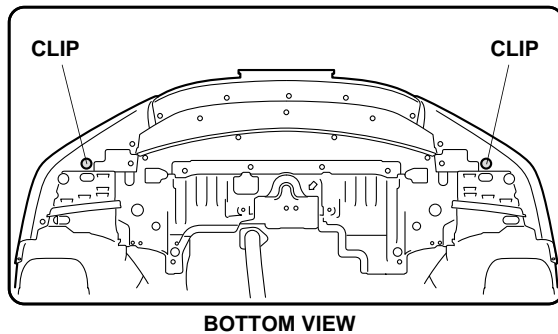
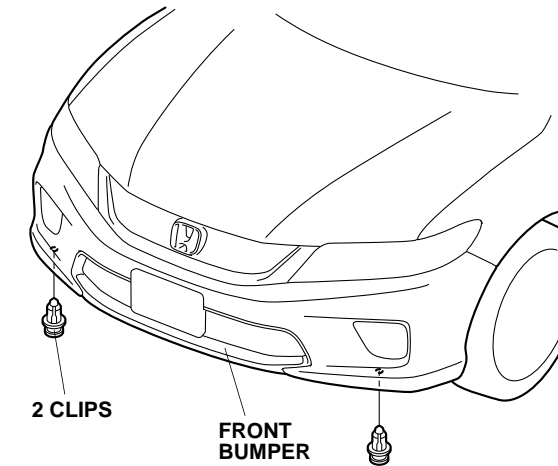

QB40304AE

2. With the vehicle on a lift, align the template on the left side of the front bumper in the area shown, and tape it in place with masking tape.

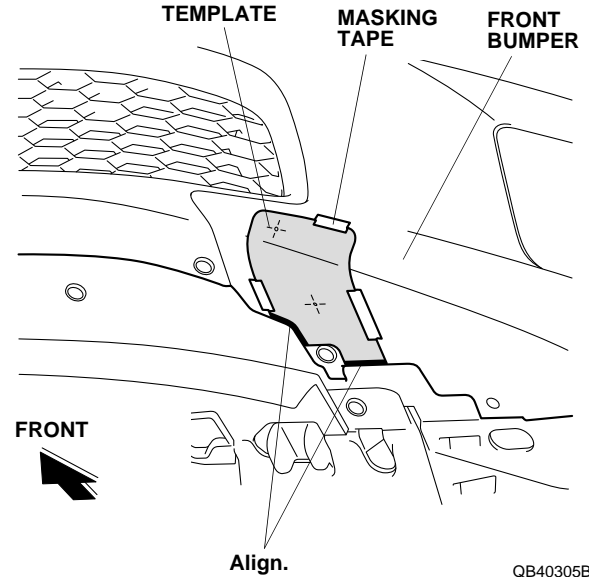

QB40305BE

3. Using a pushpin, pierce the front bumper through the two holes in template. Remove the template.

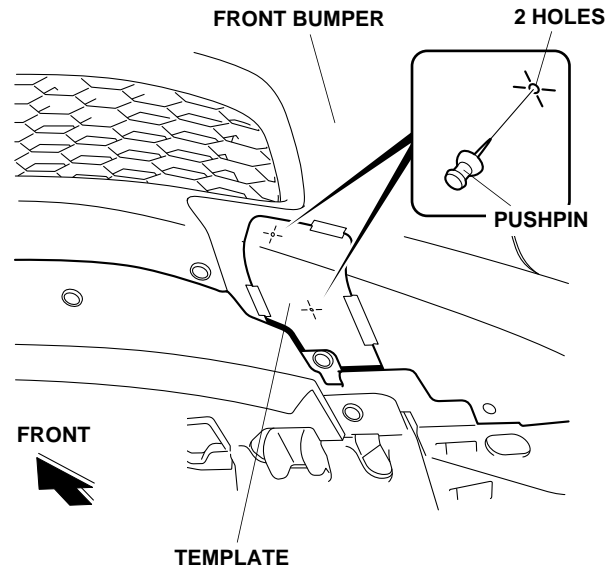

QB40401BE

4. While wearing eye protection, drill the front bumper:
- Wrap electrical tape around a 3 mm, 10 mm, and 12 mm drill bit 10 mm (0.4 in.) away from the tip, or use a drill stop.
 - Using a 3 mm drill bit, drill both pierced marks on the front bumper.
 - Using a 12 mm drill bit, enlarge the upper 3 mm hole to 12 mm. Remove any burrs.
 - Using a 10 mm drill bit, enlarge the lower 3 mm hole to 10 mm. Remove any burrs.

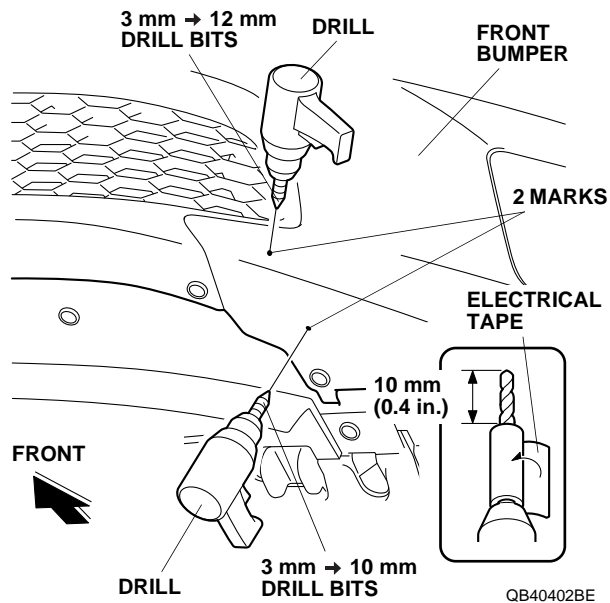

5. Install one clip into the upper 12 mm hole in the direction shown. Push on the clip in until you hear it “click,” then check to make sure the clip is secure in the front bumper.

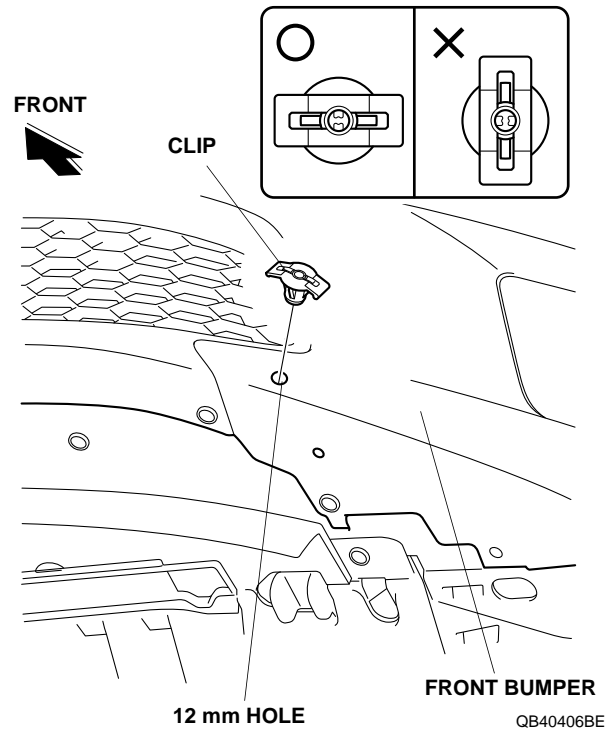

6. Using a pushpin, pierce the left front bumper at the two dimples on the front fenderwell.

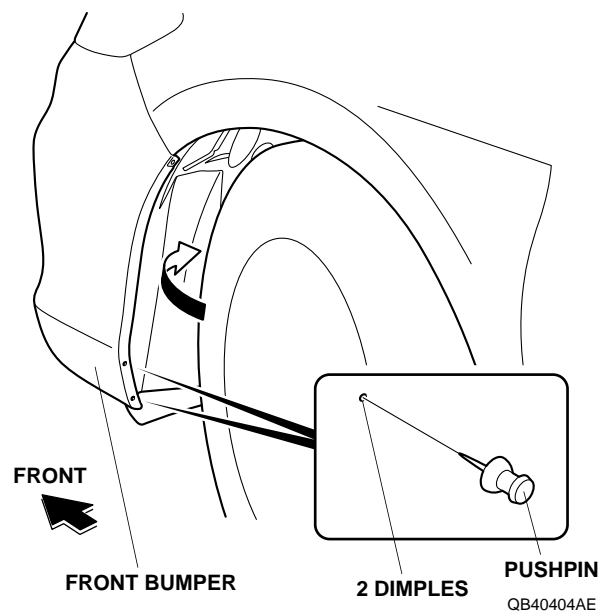

7. Thread a self-tapping screw into each pierced mark to make a hole in the front bumper. Remove the self-tapping screw.

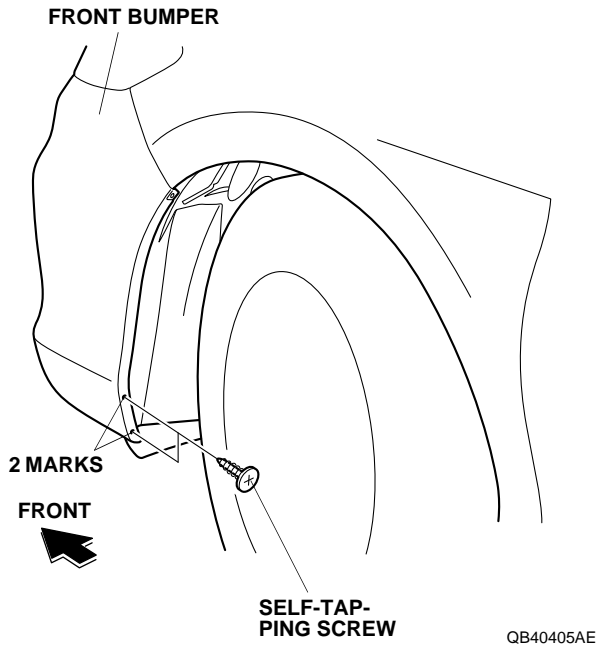

8. Install one spring nut over each hole in the front bumper in the direction shown.

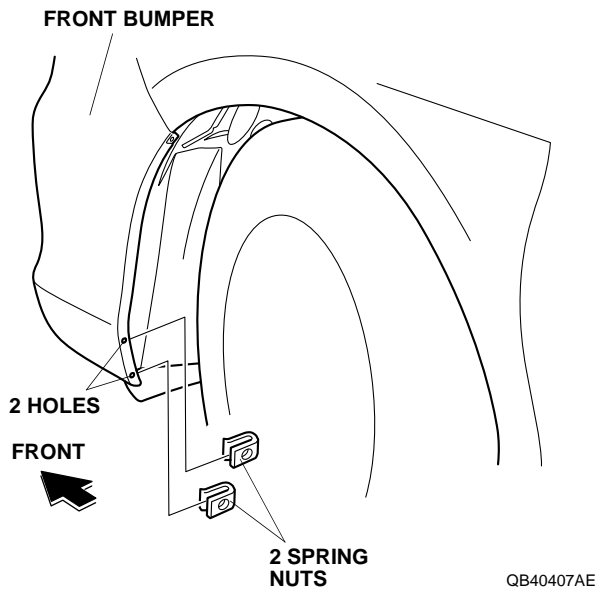

9. Peel back the adhesive backing, and tape it to the front surface of the left front under spoiler with masking tape.

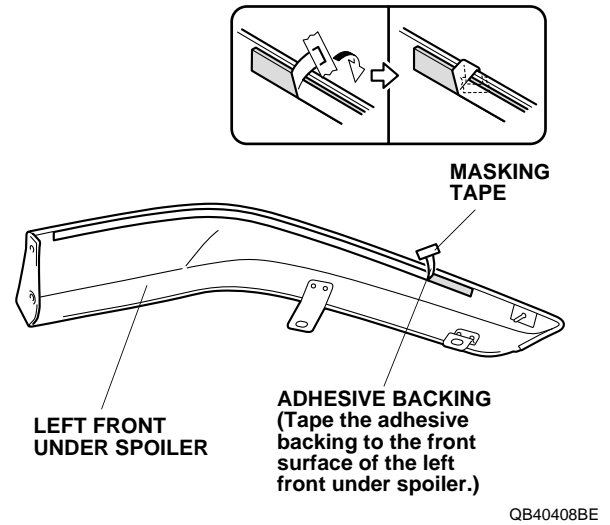

10. Using one alcohol swab, thoroughly clean the front bumper where the left front under spoiler will attach.

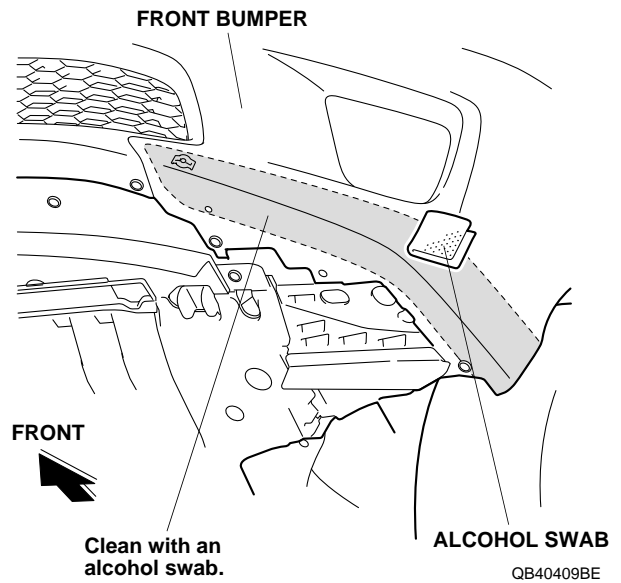

11. Install the left front under spoiler to the front bumper, and loosely install two self-tapping screws into the spring nuts in the fenderwell.

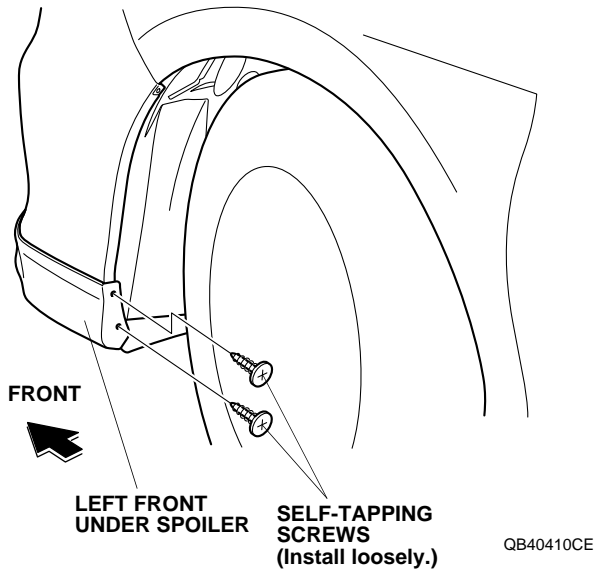
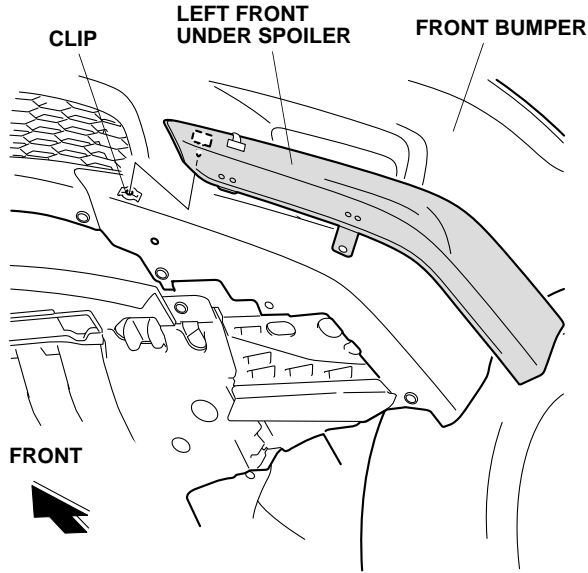

12. Secure the front portion of the left front under spoiler to the front bumper with one washer and one bumper clip supplied.

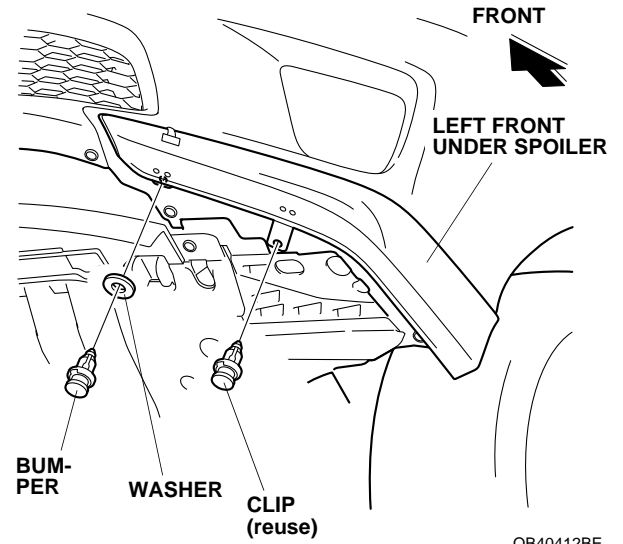

13. Secure the middle portion of the left front under spoiler to the front bumper with one clip removed in step 1.
14. While applying light pressure against the left front under spoiler, carefully remove the adhesive backing as shown.

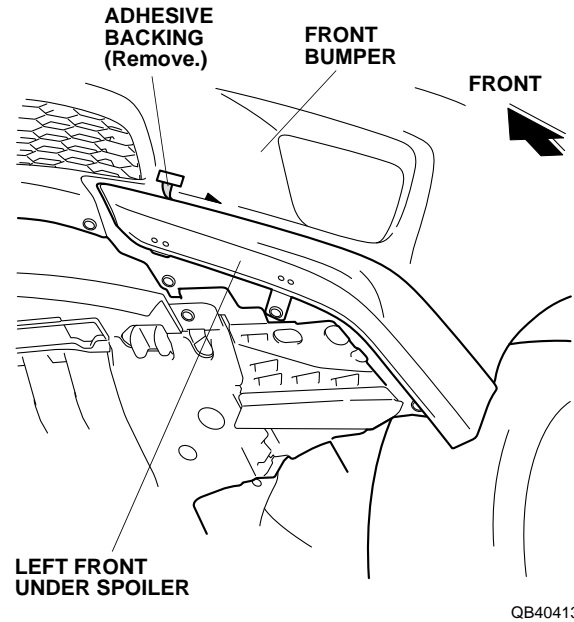

15. Using you hand, firmly press the left front under spoiler against the front bumper for 30 second.

16. Using a rubber roller, apply firm pressure while rolling to set the adhesive, especially at the ends.

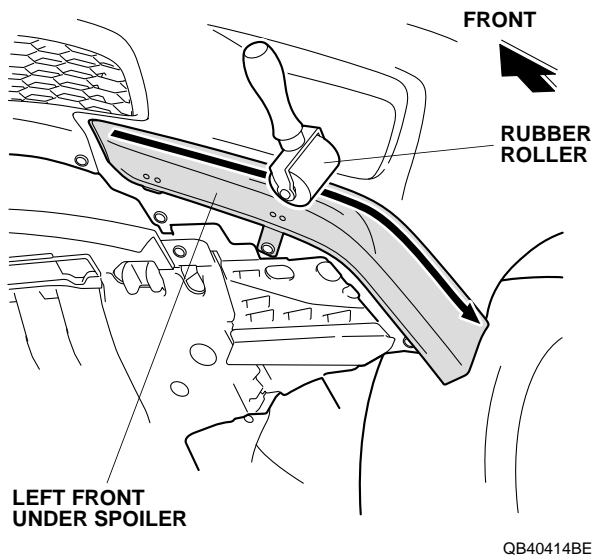

17. Tighten the two self-tapping screws installed in step 11.
- Make sure that there is no gap between the front under spoiler and front bumper. If there is the gap, use spacers to adjust the gap.
 - Spacer thickness of "1" and "2" represent 1 mm and 2 mm respectively.
 - Do not use two of the 2 mm spacers together. Using two of the 2 mm spacers will create an unsightly condition.

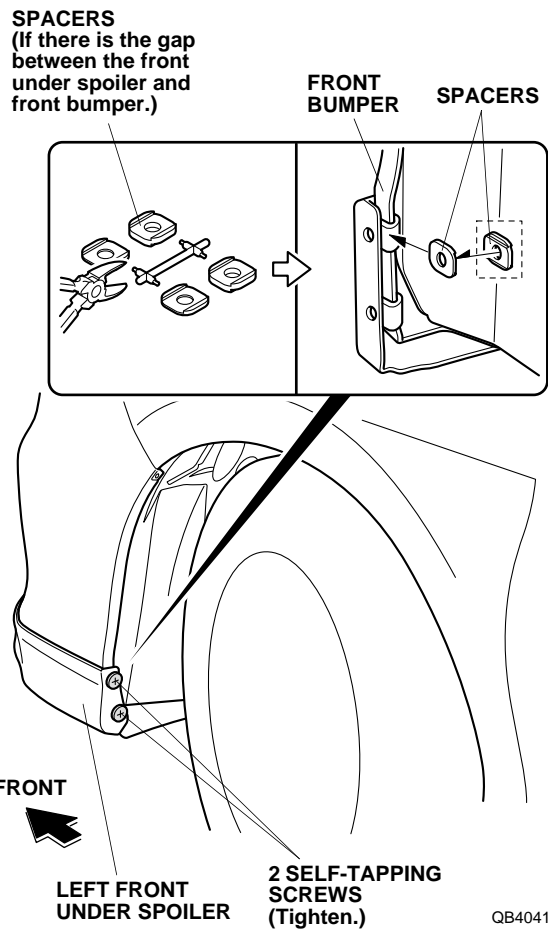

18. Turn the template over and repeat steps 2 through 17 to install the right front under spoiler on the right side of the vehicle.