



INSTALLATION INSTRUCTIONS

Accessory
BACKUP SENSORS

Application
**2013 ACCORD
2-DOOR**

Publications No.
All 13009
Issue Date
OCT 2012

PARTS LIST

Backup Sensors Attachment Kit P/N 08V67-T3L-100A

Control unit

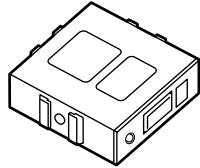

Control unit bracket A

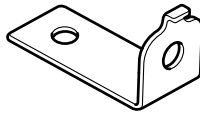

Control unit bracket B

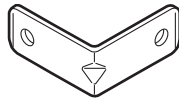

Buzzer

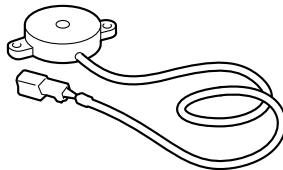

Backup sensor harness

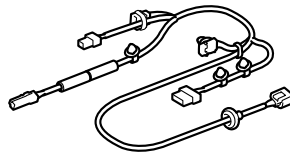

Subharness

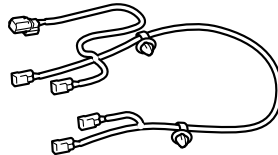

2 Left sensor clips (White)

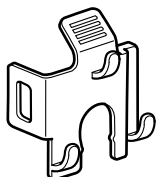

2 Right sensor clips (Black)

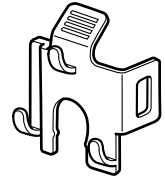

7 Wire ties

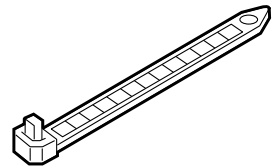

2 Aluminum tapes



Urethane tape

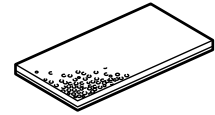

Fuse label



Flange bolt

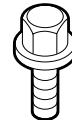

Wire tie with holder
(May not be used)

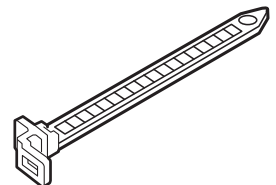

Connector clip
(May not be used)

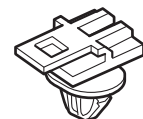

Accessory User's Information Manual

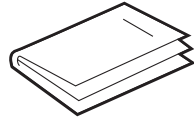

Backup Sensor Kit P/N 08V67-T3L-100K

Left center sensor
(Larger than the corner sensor)

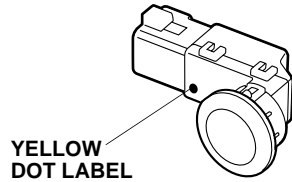

Right center sensor
(Larger than the corner sensor)

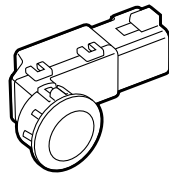

Left corner sensor

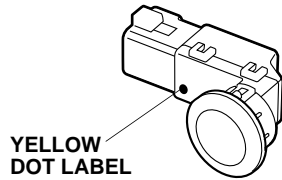

Right corner sensor

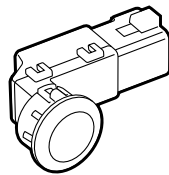

TOOLS AND SUPPLIES REQUIRED

- Phillips screwdriver
- Small flat-tip screwdriver
- 10 mm Open end wrench
- 10 mm and 14 mm Sockets
- Pushpin
- Ratchet
- 3 mm Drill bit
- Eye protection (face shield, safety goggles, etc.)
- File
- Blanket
- Isopropyl alcohol
- Shop towel
- 24 mm and 26 mm Hole saws
- Drill
- Hex wrench
- Diagonal cutters
- Masking tape

The following tool is available through the Honda Tool and Equipment Program. On the iN, click on: Service > Service Bay > Tool and Equipment Program, then enter the number under "Search." Or, call 888-424-6857.

- Trim Tool Set (T/N SOJATP2014)

Illustration of the Backup Sensors on the Vehicle

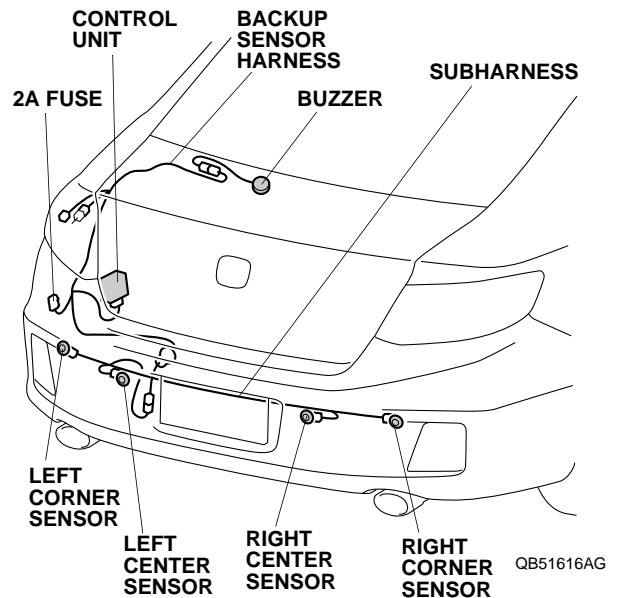

INSTALLATION

Customer Information: The information in this installation instruction is intended for use only by skilled technicians who have the proper tools, equipment, and training to correctly and safely add equipment to your vehicle. These procedures should not be attempted by “do-it-yourselfers.”

NOTE: Refer to Parts Information Bulletin (PIB) for the proper color sensors.

1. Disconnect the negative cable from the battery.
2. Pull the lever to fold the rear seat back forward.

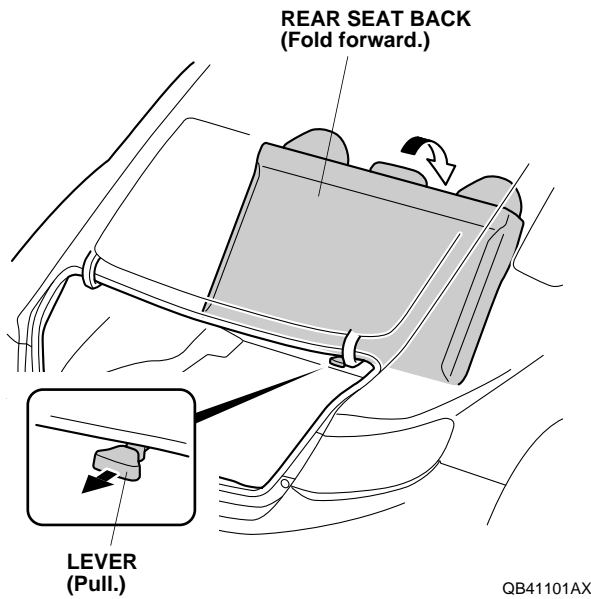

3. Remove the trunk floor (two clips).

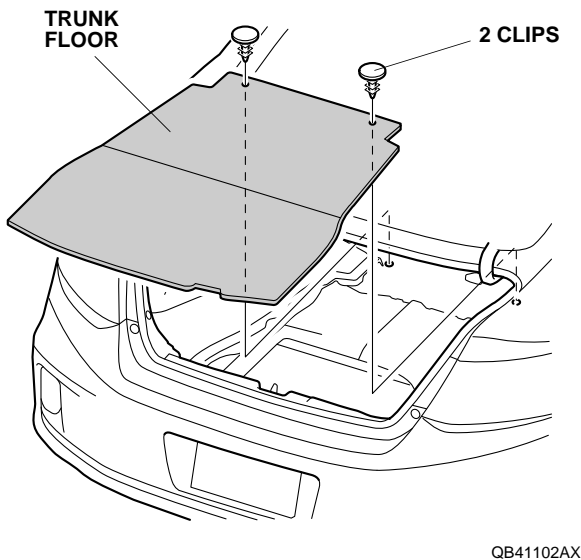

4. Remove the trunk rear trim panel (four clips and five hooks).

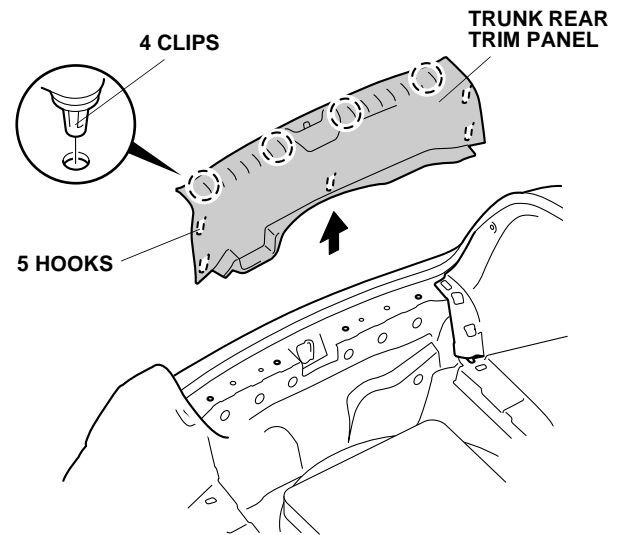

5. Push in on the two tabs, and remove the cargo hook.

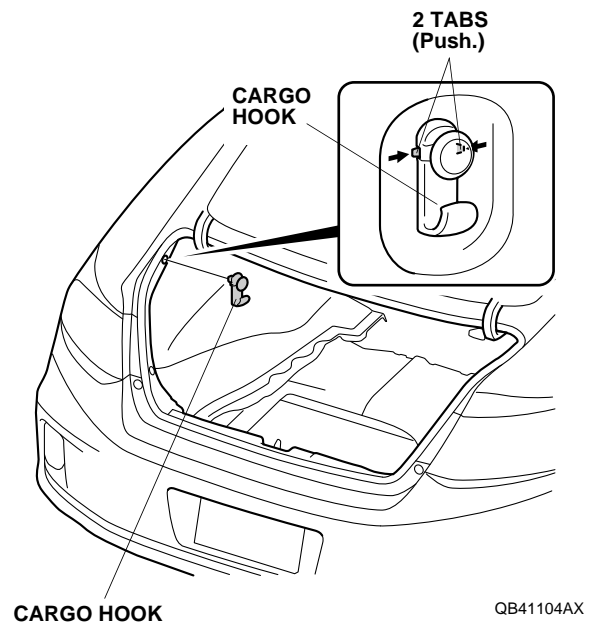

6. Pull away the weatherstrip. Remove the left trunk side trim panel (five clips).

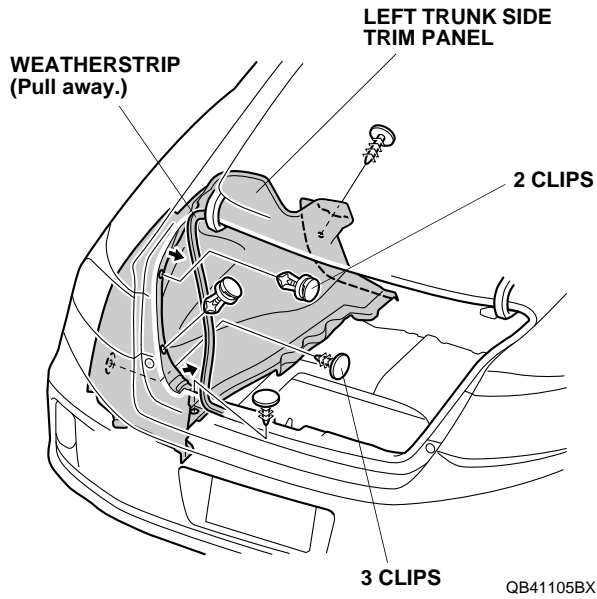

7. Remove the rear bumper.
 - On each side of the vehicle, attach masking tape to the rear bumper, taillight, and rear fender as shown.

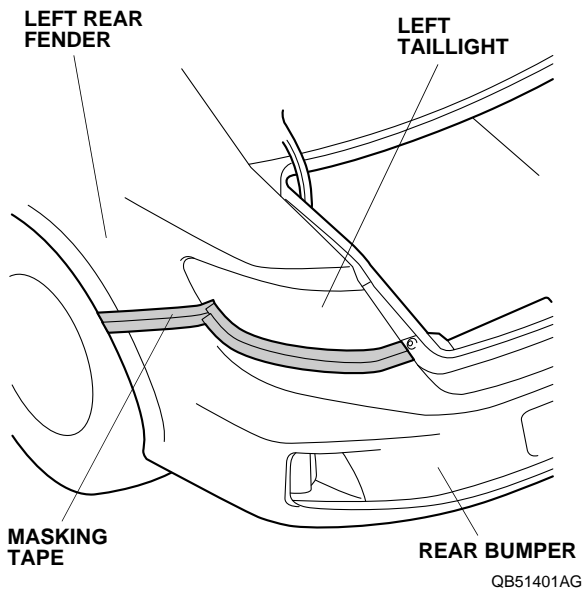

- Remove the two bumper screws, four self-tapping screws and four clips.

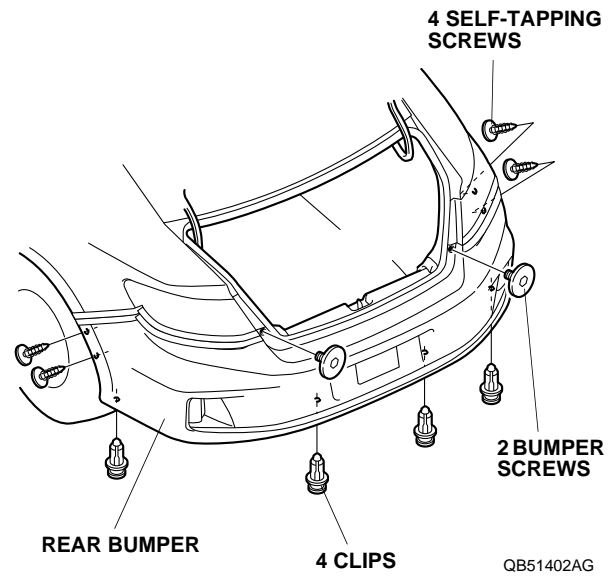

- Release the six retaining tabs on each side of the bumper.

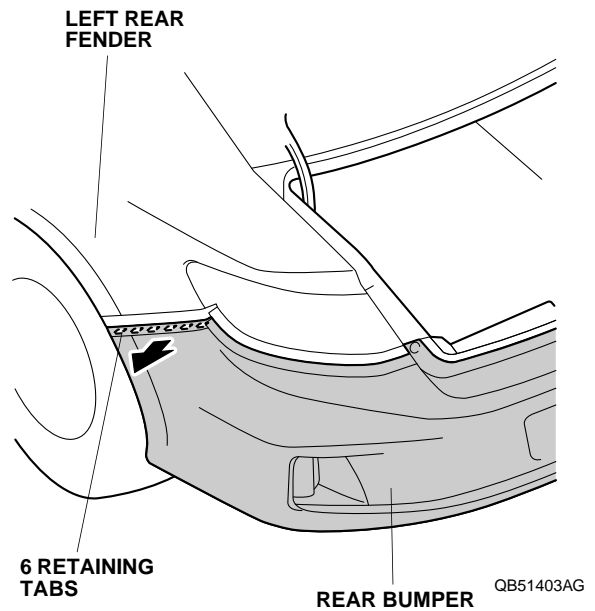

- Release the three retaining tabs on each side of the bumper.

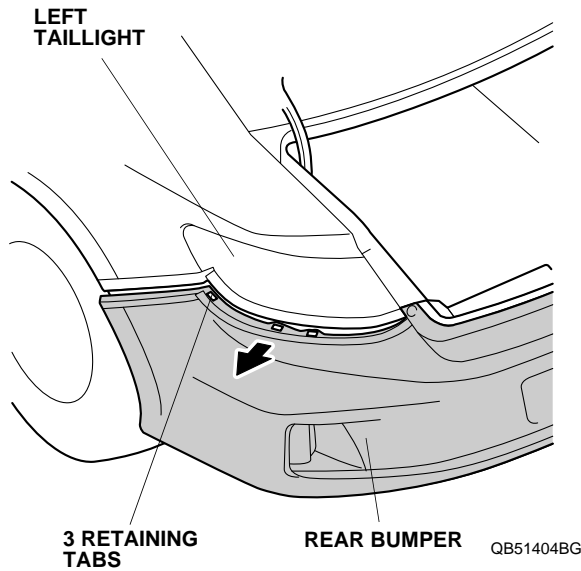

- With the help of an assistant, unplug the vehicle connectors, remove the rear bumper (four retaining tabs).

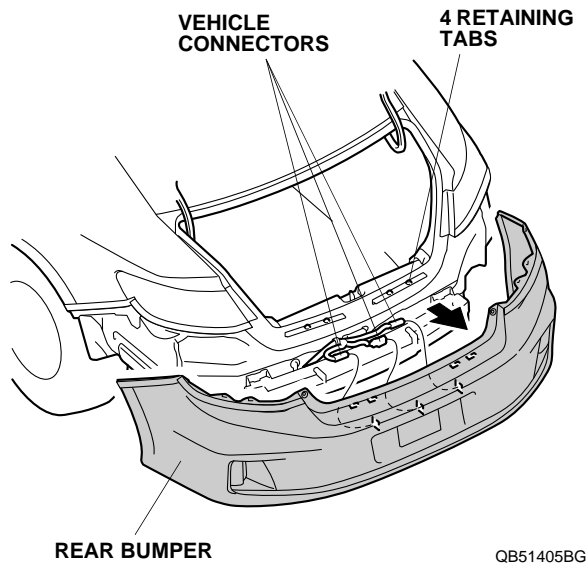

- Place the rear bumper on a blanket.

8. Mark the inside of the rear bumper on the left side:
 - Locate two scribe marks on the inside of the rear bumper at the left and center side.
 - Using a pushpin, pierce the rear bumper at the bottom and center of the left mark.
NOTE: Make sure to pierce the scribe marks perpendicularly to the rear bumper.
 - Using a pushpin, pierce the rear bumper at the top and center of the left center mark.
NOTE: Make sure to pierce the scribe marks perpendicularly to the rear bumper.

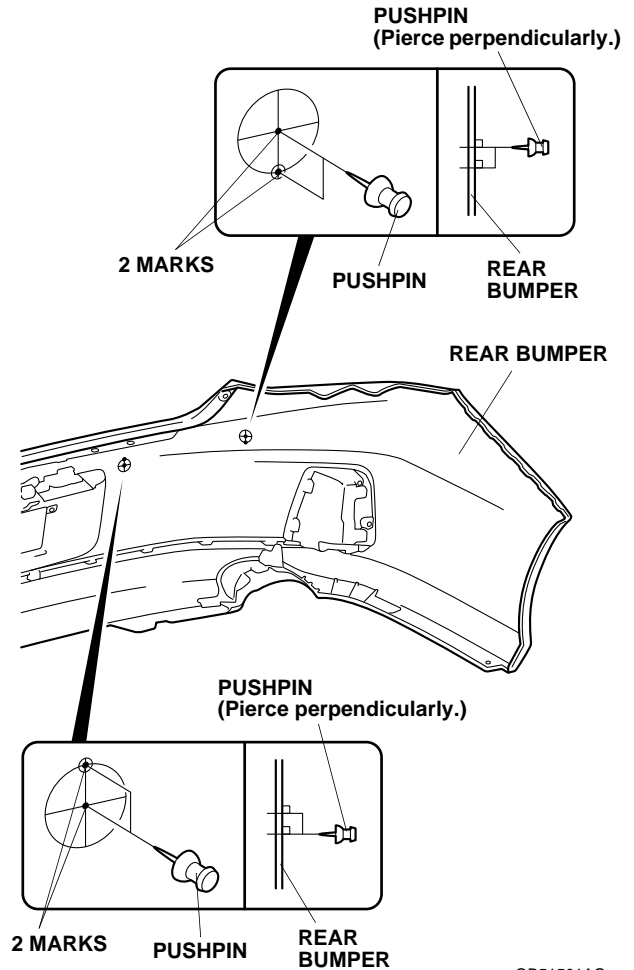

9. Mark the inside of the rear bumper on the right side:

- Locate two scribe marks on the inside of the rear bumper at the right and center side.
- Using a pushpin, pierce the rear bumper at the bottom and center of the right mark.
NOTE: Make sure to pierce the scribe marks perpendicularly to the rear bumper.
- Using a pushpin, pierce the rear bumper at the top and center of the right center mark.
NOTE: Make sure to pierce the scribe marks perpendicularly to the rear bumper.

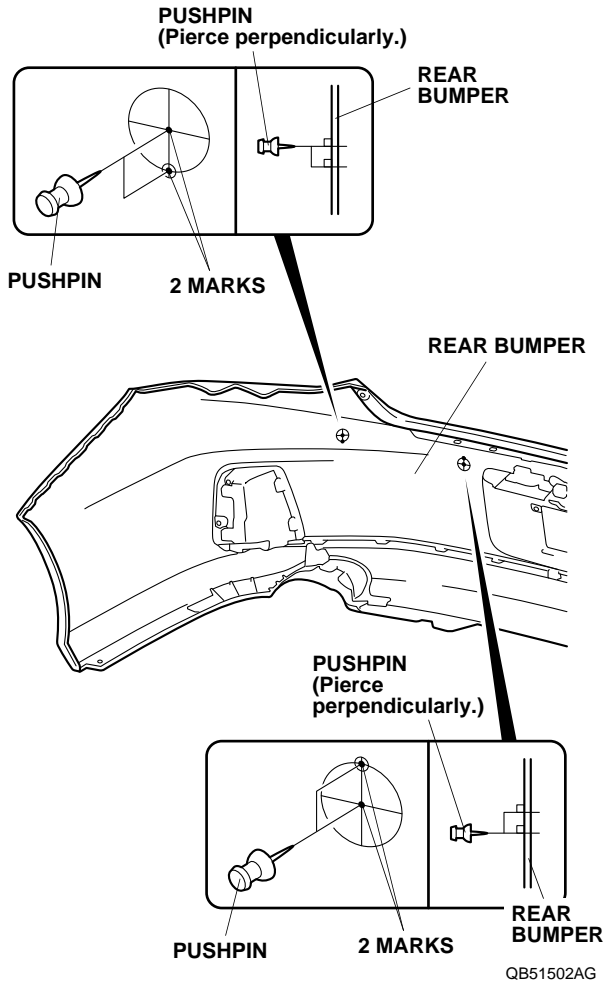

10. While wearing eye protection, drill all eight pierced marks:

- NOTE: Make sure to drill perpendicularly to the rear bumper.
- Using a 3 mm drill bit, drill each pierced mark from the outside of the rear bumper.

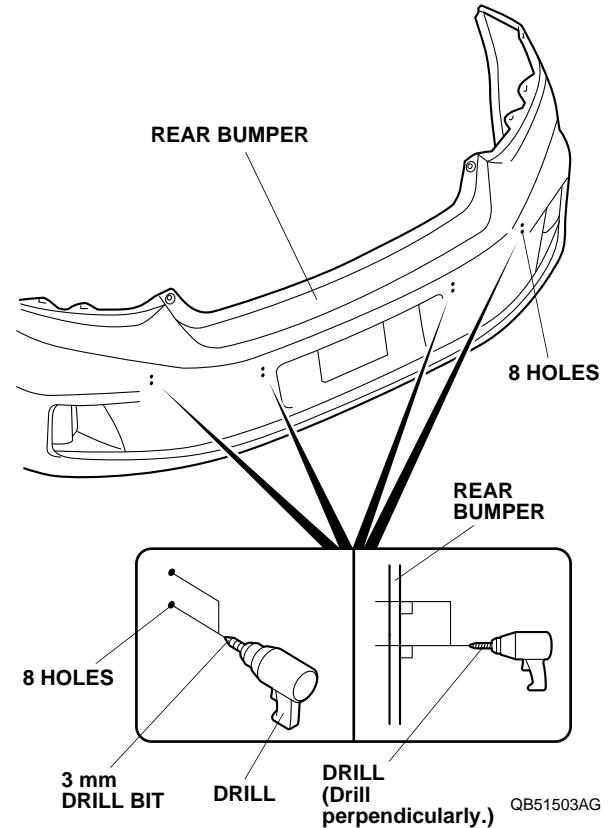

- Using a 24 mm hole saw, enlarge the outboard (left and right corner sensor) bumper holes by drilling the upper 3 mm holes. Remove any burrs.

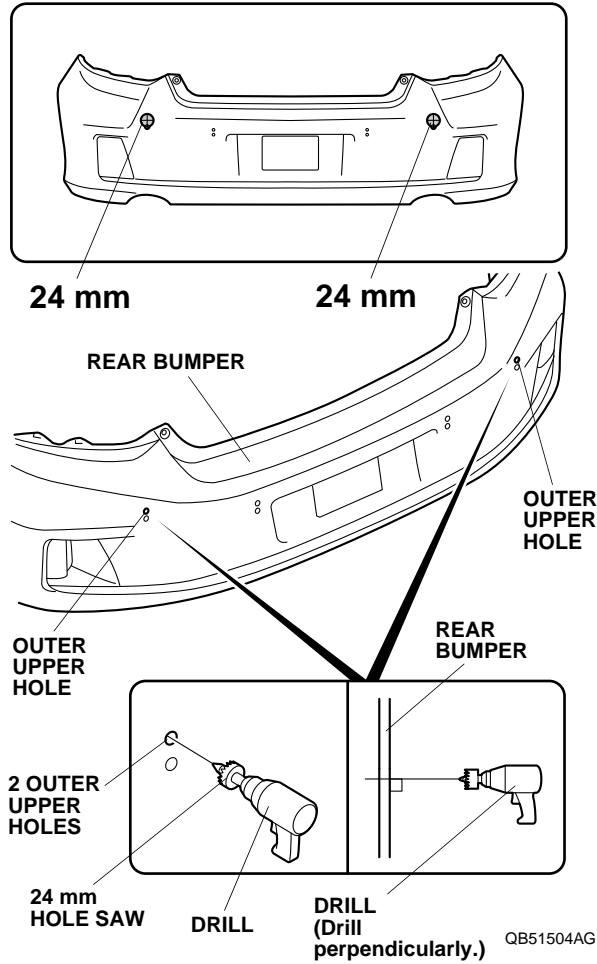

- Using a 26 mm hole saw, enlarge the inboard (left and right center sensor) bumper holes by drilling the lower 3 mm holes. Remove any burrs.

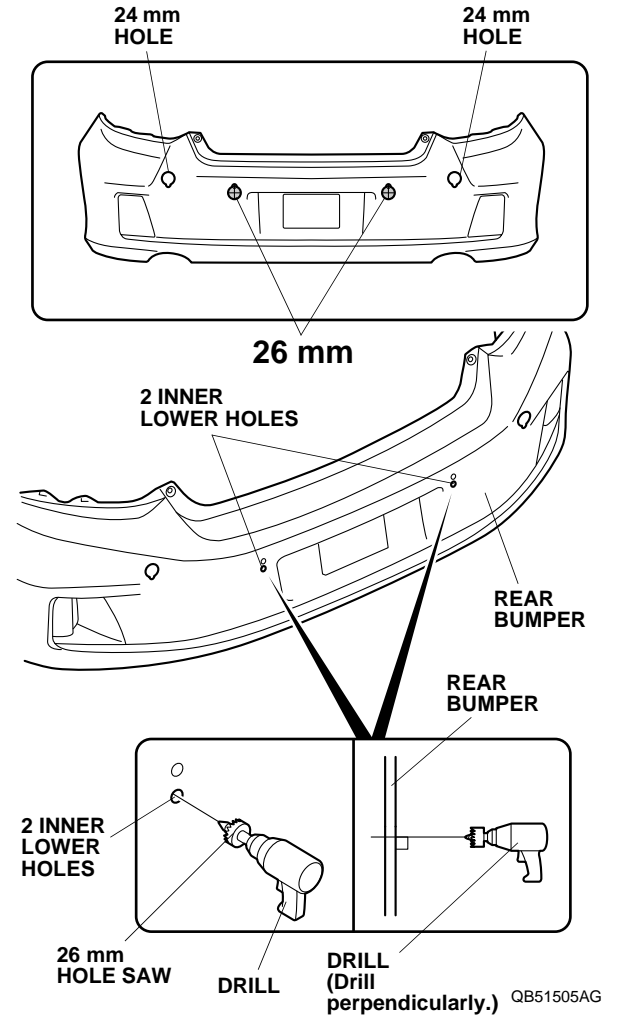

11. Using the sensor clips, install the left corner sensor and left center sensor into the 24 mm hole and 26 mm hole in the rear bumper. Note the direction and the pin location for each sensor.

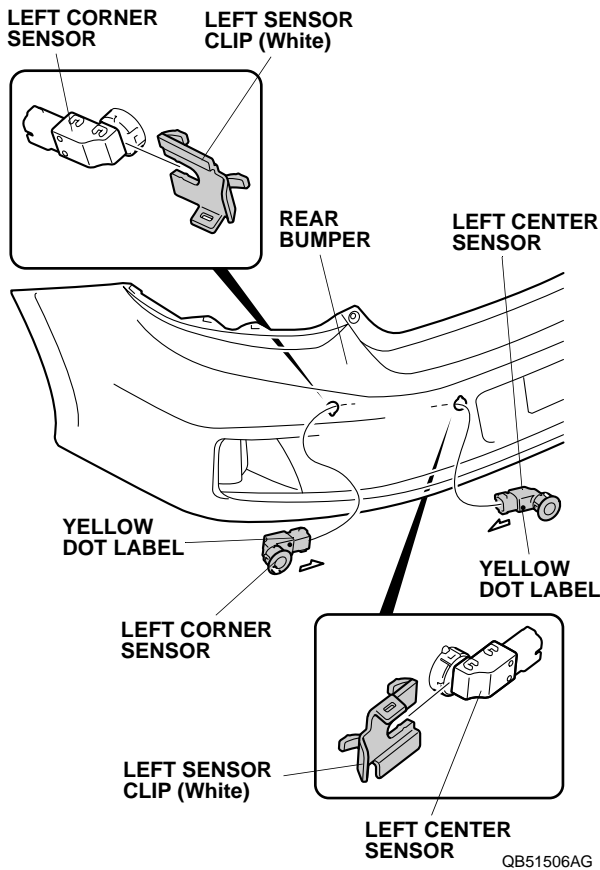

12. Using the sensor clips, install the right corner sensor and right center sensor into the 24 mm hole and 26 mm hole in the rear bumper. Note the direction and the pin location for each sensor.

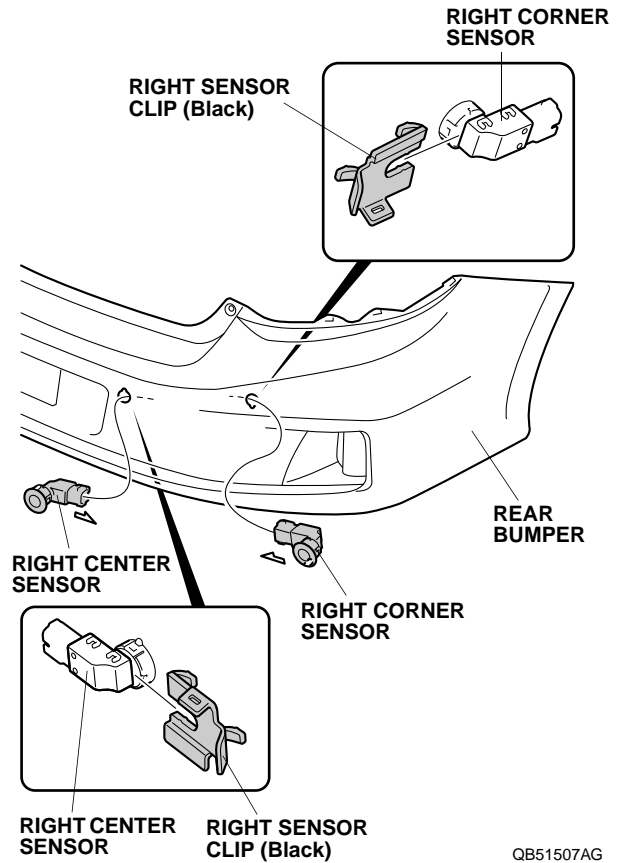

13. Plug the four subharness 2-pin connectors into the left center sensor, left corner sensor, right center sensor, and right corner sensor.

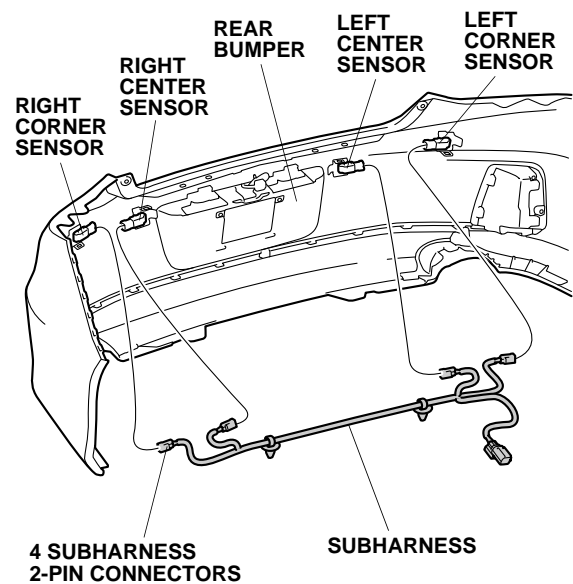

14. Secure the two subharness clips to the left sensor clip and right sensor clip as shown.

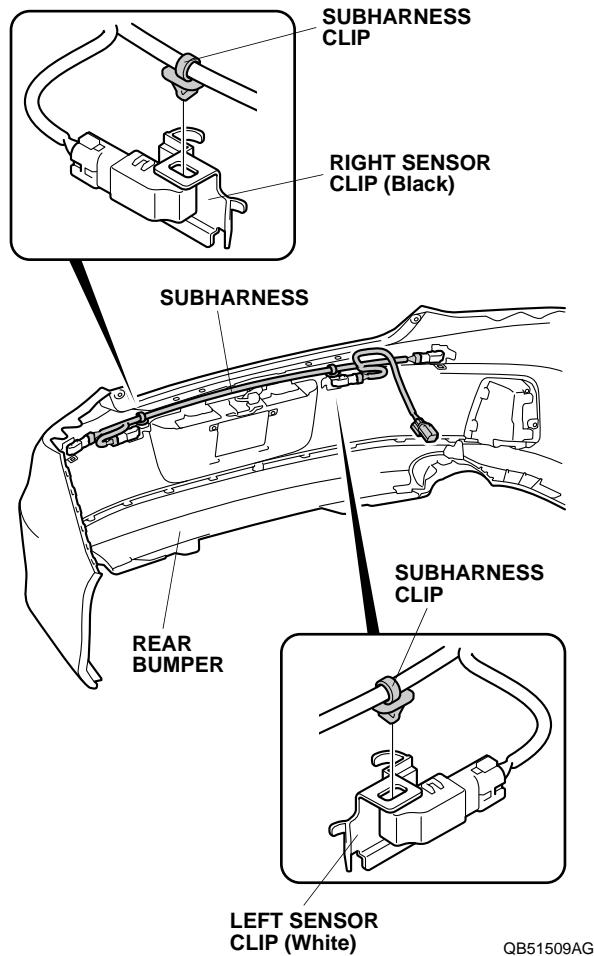

15. Using isopropyl alcohol on a shop towel, thoroughly clean the rear bumper where the aluminum tapes will attach.

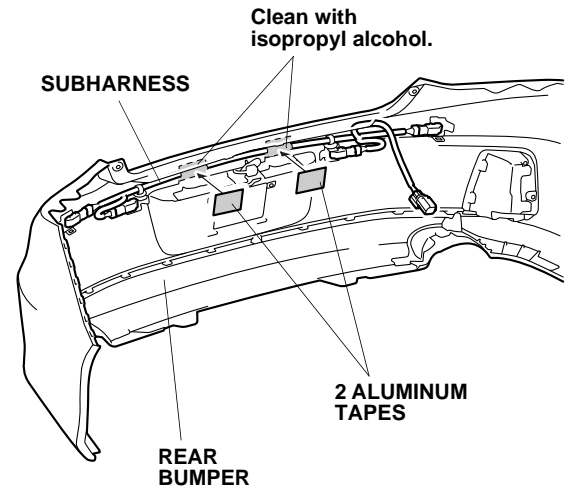

16. Secure the subharness to the rear bumper with two aluminum tapes.
17. Using isopropyl alcohol on a shop towel, thoroughly clean the vehicle panel where the buzzer will attach.

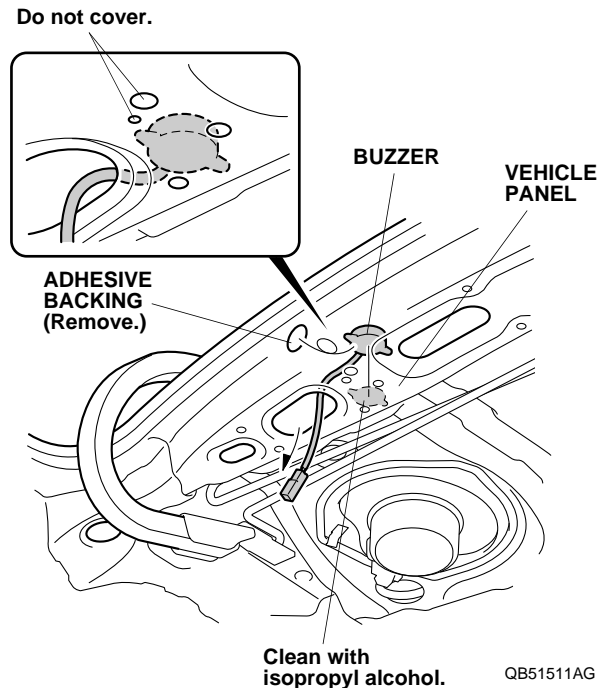

18. Remove the adhesive backing from the buzzer and attach it to the vehicle panel.
NOTE: Make sure the buzzer is attached in the correct position. Do not cover the installation holes.

19. Using isopropyl alcohol on a shop towel, thoroughly clean the fuse case where the fuse label will attach. Attach 2A fuse label to the fuse case on the backup sensor harness.

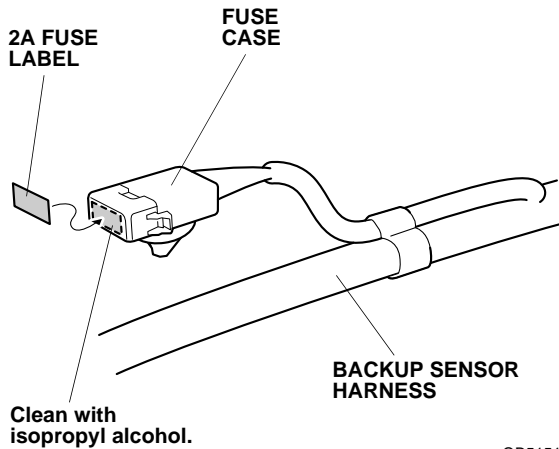

21. Secure the clip on the backup sensor harness to the vehicle panel.

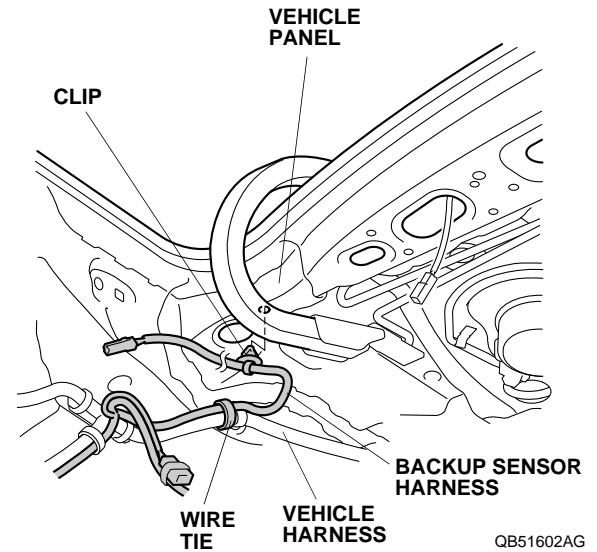

22. Secure the backup sensor harness to the vehicle harness with one wire tie.
23. Route the backup sensor harness as shown, and plug the backup sensor harness 2-pin connector into the buzzer harness 2-pin connector.

20. Secure the backup sensor harness to the vehicle harness with one wire tie.

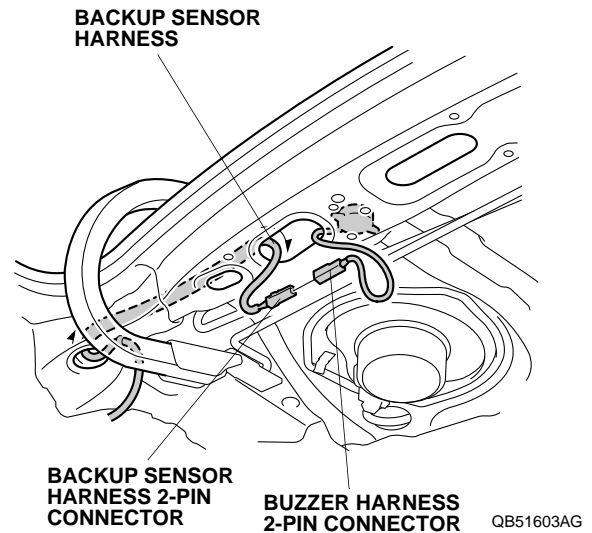
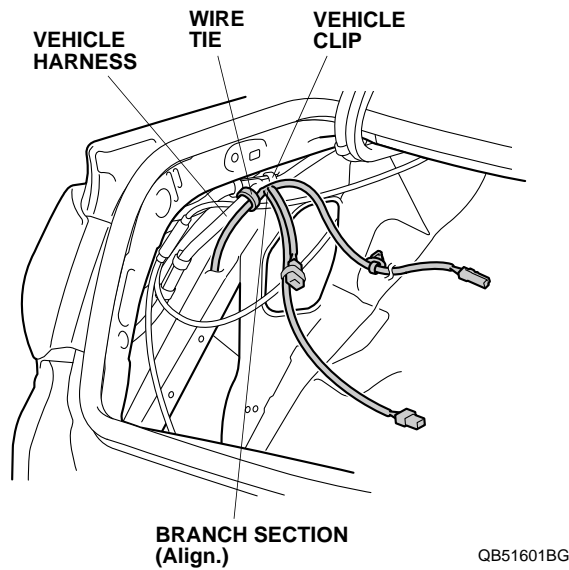

24. Using isopropyl alcohol on a shop towel, thoroughly clean the vehicle panel where the urethane tape will attach.

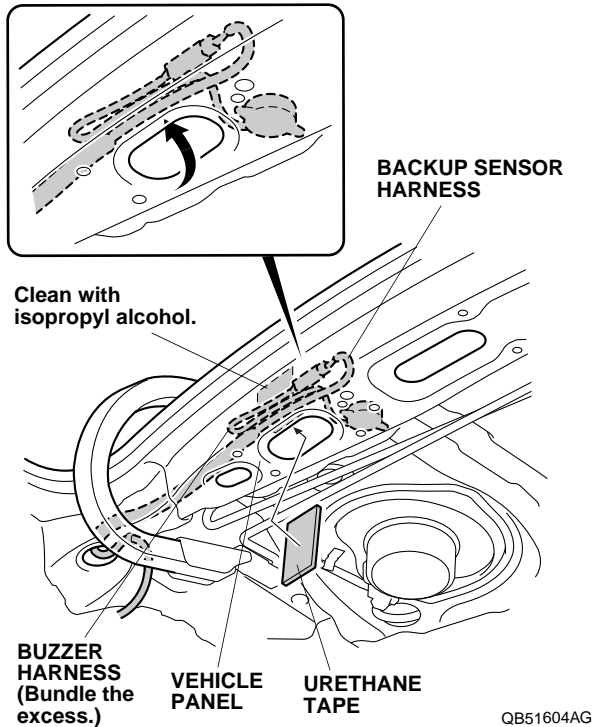

25. Bundle the excess buzzer harness, and secure the buzzer harness and backup sensor harness to the vehicle panel with one urethane tape as shown.
26. Unplug the vehicle 2-pin connector from the left backup light, and plug it into the backup sensor harness 2-pin connector.

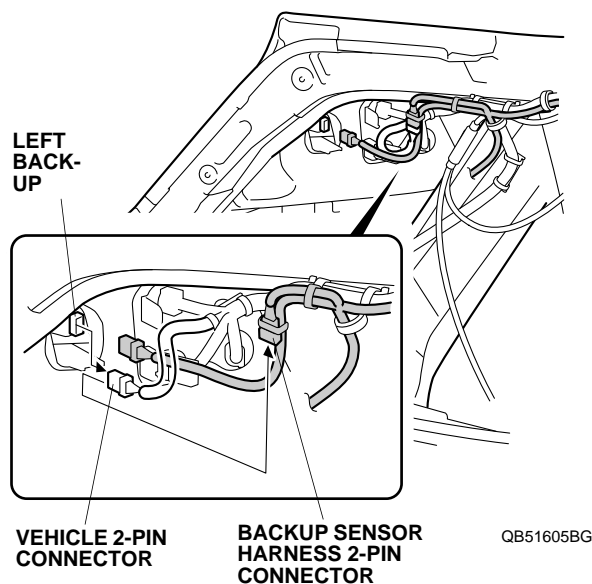

27. Plug the backup sensor harness 2-pin connector into the left backup light.

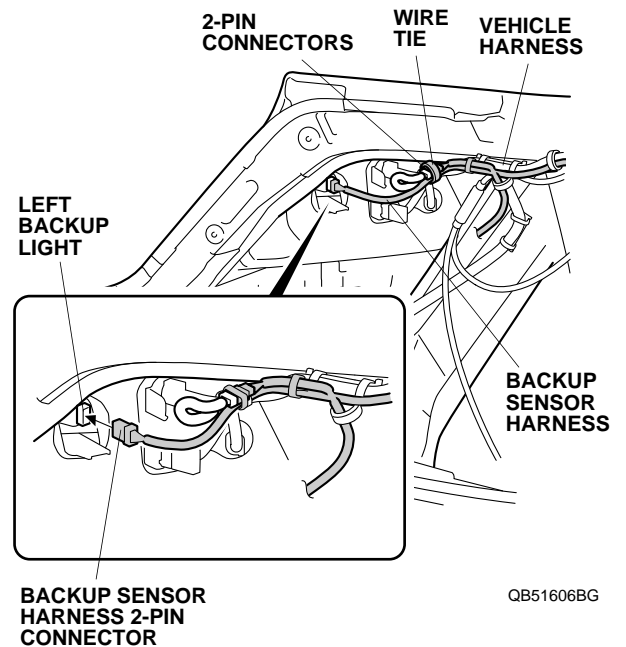

28. Secure the 2-pin connectors to the vehicle harness with one wire tie.
29. Route the backup sensor harness along the vehicle harness, and secure the clip on the backup sensor harness fuse case to the vehicle panel.

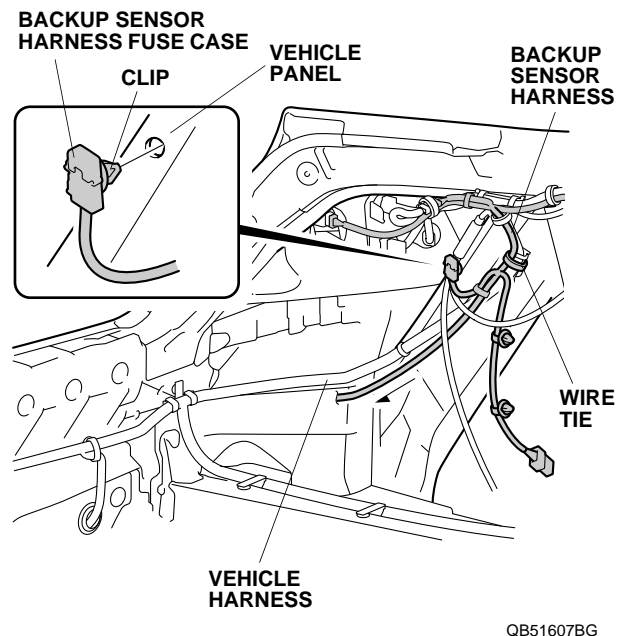

30. Secure the backup sensor harness to the vehicle harness with one wire tie.

31. Install the control unit bracket A and control unit bracket B to the control unit.

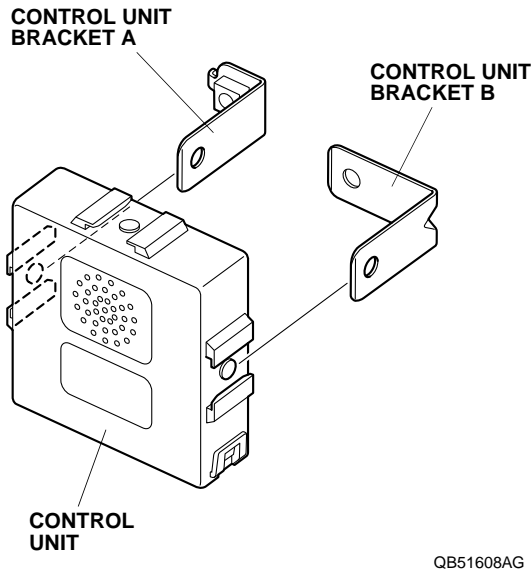

32. Secure the control unit to the vehicle panel with the flange bolt at the location shown.

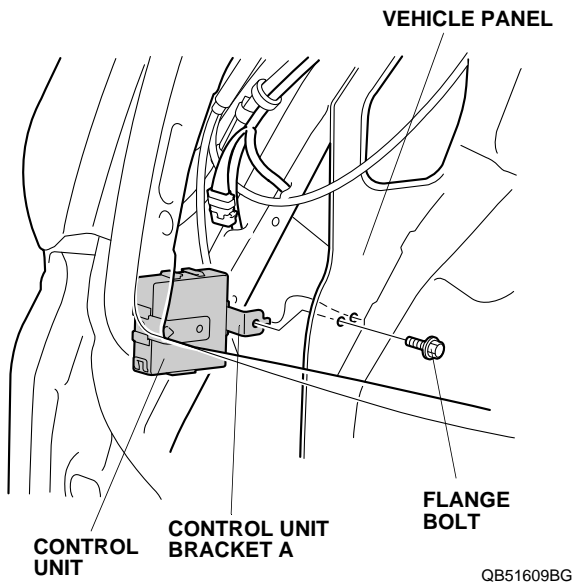

33. Plug the backup sensor harness 14-pin connector into the control unit.

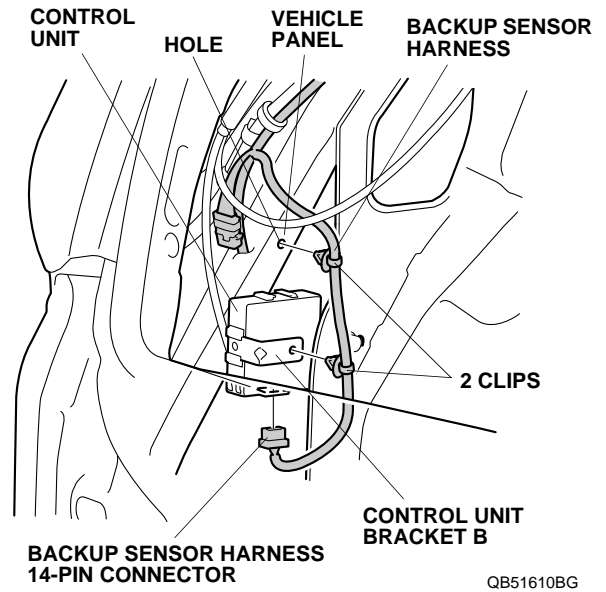

34. Secure the two clips on the backup sensor harness to the control unit bracket B and hole in the vehicle panel.

35. Route the backup sensor harness along the vehicle harness.

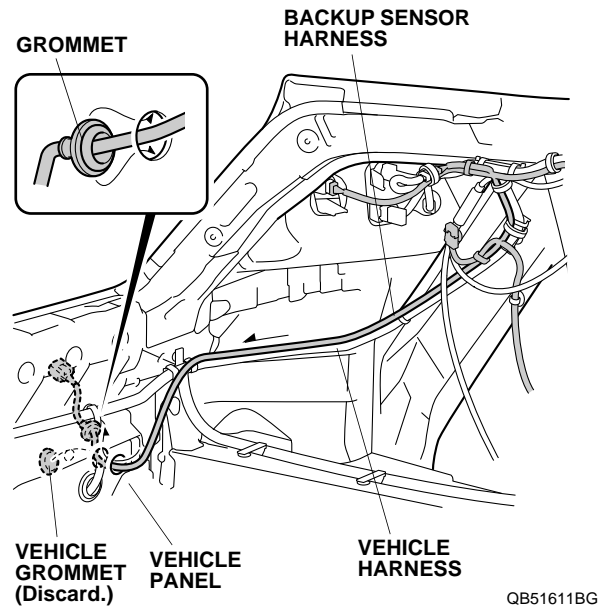

36. Locate and remove the vehicle grommet from the rear panel.

37. Route the backup sensor harness through the hole, and seat the grommet on the backup sensor harness in the vehicle panel hole.

NOTE: Do not pull on the backup sensor harness when installing the grommet.

38. Secure the backup sensor harness to the vehicle harness with three wire ties.

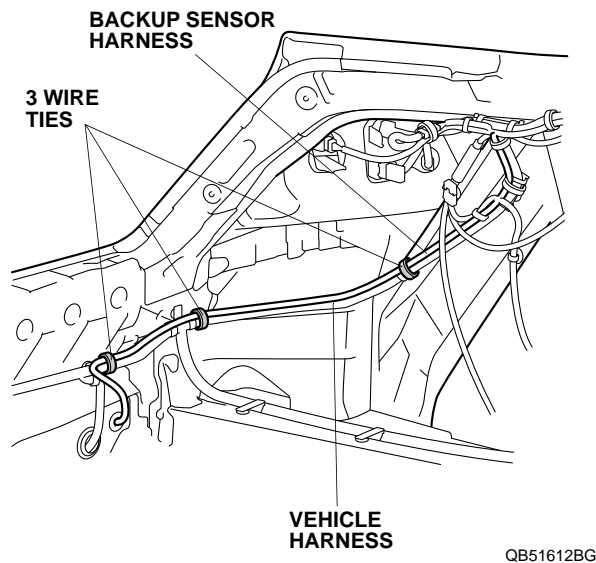

39. If equipped with vehicle harness, install the wire tie with holder to the backup sensor harness 8-pin connector, and secure it to the vehicle harness. Go to step 41.

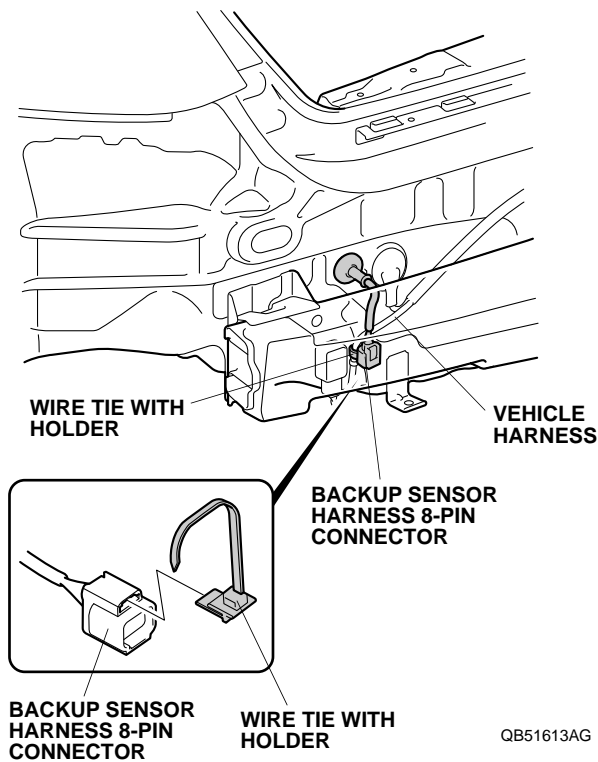

40. Install the connector clip to the backup sensor harness 8-pin connector, and secure it to the vehicle panel.

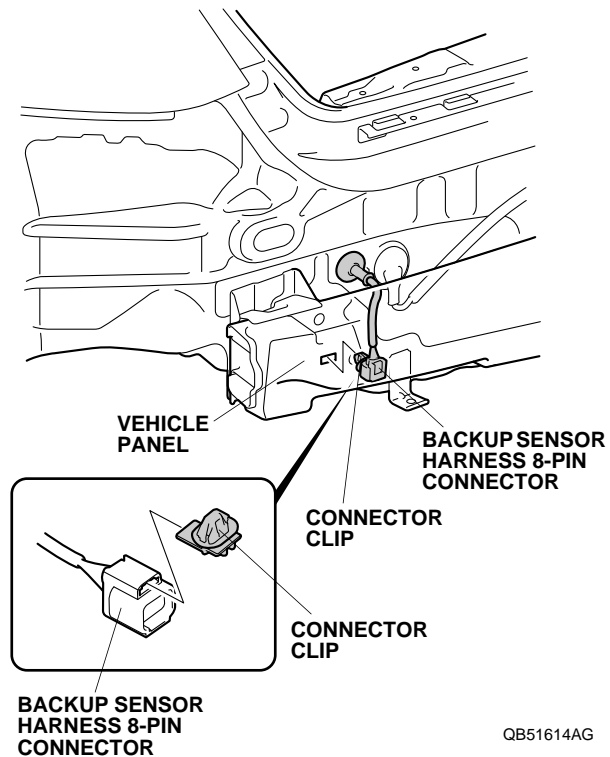

41. With the help of an assistant, bring the rear bumper next to the rear of the vehicle, plug the subharness 8-pin connector into the backup sensor harness 8-pin connector, and reinstall the rear bumper.

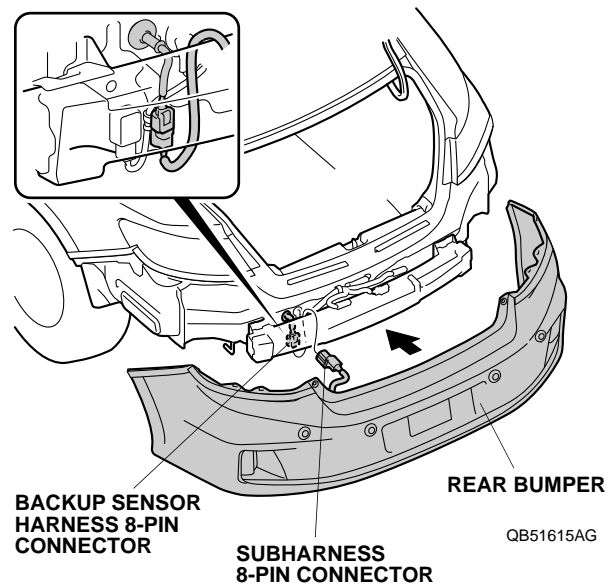

42. Check that all wire harnesses are routed properly and that all connectors are plugged in.
43. Reinstall all removed parts.
44. Reconnect the negative cable to the battery.
45. Press and hold the radio power button for two seconds to restore the radio and navi (if equipped) system functions.
46. Reset the clock on vehicle without navigation.
47. Check that the backup sensors work properly as described in the Accessory User's Information Manual supplied with the backup sensors attachment kit.

Adjust the Volume Control

The factory setting is maximum volume. After confirming the operation, turn the volume control knob to the appropriate level, using a small flat-tip screwdriver. Do not force the adjuster as it could damage the unit.

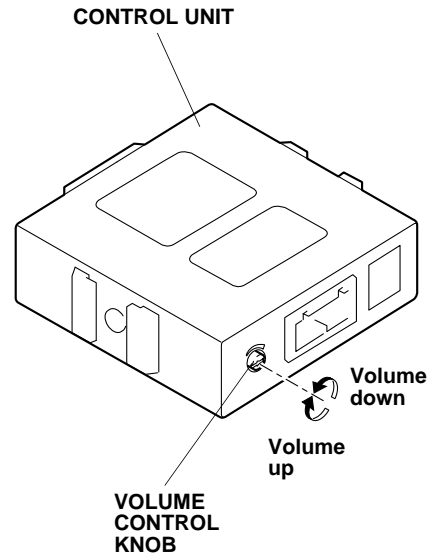

QB21606AG