



INSTALLATION INSTRUCTIONS

Accessory
19" ALUMINUM WHEEL

Application
2021 ACCORD

Publications No.
VERSION 1

Issue Date
SEP 2020

PARTS LIST

Aluminum Wheel Kit P/N 08W19-TVA-100A

Aluminum wheel
(The illustration may differ from the actual wheel.)



Wheel center cap
(The illustration may differ from the actual center cap.)



Valve



TPMS Information
(This is for models not equipped with standard 19" wheels.
Make sure your customer receives this information.)

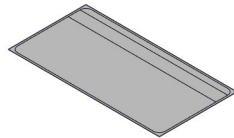

Tire pressure information label A
(May not be used)

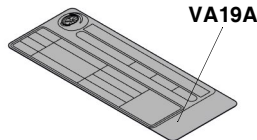

Tire pressure information label B
(May not be used)

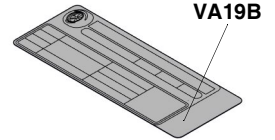

Tire pressure information label C
(May not be used)

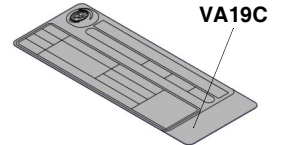

Supplemental information
(For models not equipped with standard 19" wheels)

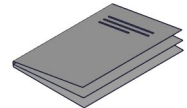

Trims Kit P/N 08W19-TVA-100B P/N 08W19-TVA-100C P/N 08W19-TVA-100E

5 Trims



15 Nuts

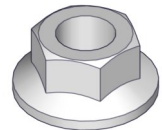

TOOLS AND SUPPLIES REQUIRED

Isopropyl alcohol
Shop towel
i-HDS
Ratchet
10 mm Socket
Torque wrench

SPECIFICATIONS

Models equipped with standard 17" wheels:

| | | |
|---------------|------------------------|------------------|
| Rim size | 19 x 8 1/2J (inset 50) | |
| Tire size | 245/35R19 93Y | |
| Bolt hole PCD | 114.3 (5 holes) | |
| Tire pressure | Front | 38 psi (260 kPa) |
| | Rear | 38 psi (260 kPa) |

Models equipped with standard 19" wheels:

| | | |
|---------------|------------------------|------------------|
| Rim size | 19 x 8 1/2J (inset 50) | |
| Tire size | 235/40R19 96V | |
| Bolt hole PCD | 114.3 (5 holes) | |
| Tire pressure | Front | 33 psi (225 kPa) |
| | Rear | 33 psi (225 kPa) |

INSTALLATION

Customer Information: The information in this installation instruction is intended for use only by skilled technicians who have the proper tools, equipment, and training to correctly and safely add equipment to your vehicle. These procedures should not be attempted by "do-it-yourselfers."

NOTE:

- The illustrations of the aluminum wheels are shown for reference purposes only.
- Install the correct size tire.
- Use a tire changer to install and remove the tires as described in the operation manual furnished with the tire changer. Do not use a tire lever to install and remove the tires as it may cause damage to the tire and aluminum wheel.
- The wheel nut torque is 80 lb-ft (108 N·m).
- This kit should be installed only if the ambient air temperature is 60°F (15°C) or above.
- To allow the tire and loading information label adhesive to cure, do not wash the vehicle for 24 hours. Make sure your customer is aware of this.

Models equipped with standard 19" wheels:

Discard the TPMS information, tire pressure information label, and supplemental information in this kit.

1. Install the trim to the aluminum wheel with the three nuts as shown. Torque the three nuts to 4.4 lb-ft (6 N·m).

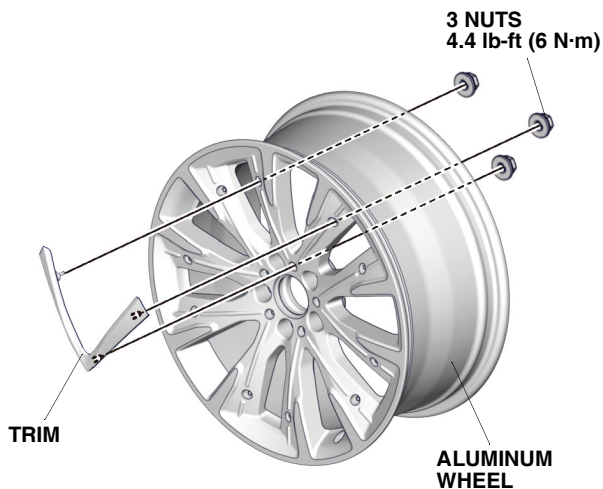

QH50901AC

2. Repeat same procedure for the remaining trims.

Perform steps 3 through 19 for models not equipped with standard 19" wheels.

3. Open the driver's door. Using isopropyl alcohol on a shop towel, thoroughly clean the area where the tire pressure information label will attach. Remove the adhesive backing from the tire pressure information label, and attach the tire pressure information label over the standard tire pressure information label as shown.

NOTE: Confirm the spare tire size, and appropriate label.

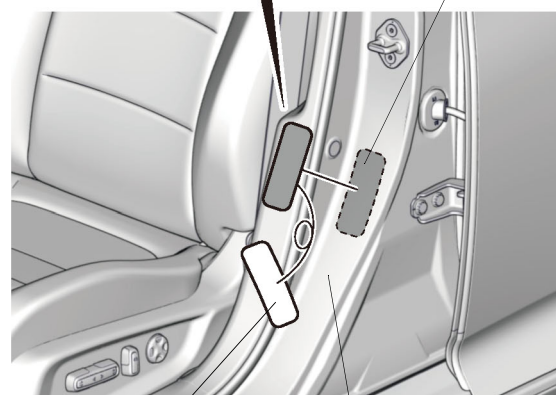
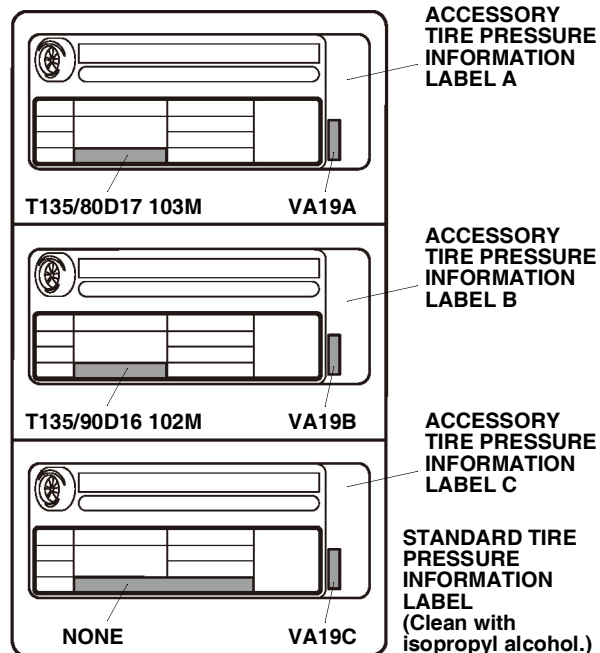

QGN0607AN

4. Attach the Supplemental Information page included in this kit into the Owner's Guide as described on the Important Information to Dealer page.

Inch-up Tire Pressure Programming

NOTE: Make sure you are using the latest i-HDS version as described on SIS.

5. Connect the i-HDS to the data link connector, then turn the ignition to ON.
6. Start the Diagnostic System, select **Connect to the Vehicle**.
7. Select **System Selection Menu**.
8. Select **ABS/VSA**, and click the check button.
9. Select **TPMS (VSA) threshold**, and click the check button.
10. Select **YES**.
11. Select **YES**.
12. Select **19 inch**, and click the check button.
13. Select **Mud and snow**, and click the check button.
14. When you see this message: **Turn the ignition switch off**. Turn the ignition to OFF.
15. When you see this message: **Turn the ignition switch on**. Turn the ignition to ON.
16. Click the check button.
17. Disconnect the i-HDS from the data link connector.
18. Do the TPMS calibration according to the instructions in the service information (TPMS Calibration).
19. After finishing the work, write tire size, tire pressure, i-HDS version, dealer name, technician's signature, and date in "Service History Page for Honda Accessory Alloy Wheels" page included in this kit.
 - Make sure your customer understands the contents of the "Supplemental Information" when delivering the vehicle.

Deflation Warning System Threshold Rewriting

- If the 17-inch wheels are to be installed back on the vehicle, you must change the threshold value with the i-HDS; refer to steps 5 to 18.
- For step 12, select the 17-inch.

NOTE: If 17-inch is displayed on the current wheel size settings, go to step 17.

- After finishing the work, write tire size, tire pressure, i-HDS version, dealer name, technician's signature, and date in "Service History Page for Honda Accessory Alloy Wheels" page.