



INSTALLATION INSTRUCTIONS

Accessory
TRUNK DRAWER
P/N 08U45-TVA-100B

Application
2019 ACCORD

Publications No.
VERSION 1
Issue Date
OCT 2018

PARTS LIST

Trunk drawer



Right rail



Left rail



6 Rivet nuts



6 Bolts



Accessory User's Information Manual



TOOLS AND SUPPLIES REQUIRED

19 mm Open end wrench

Ratchet

10 mm Socket

Hex wrench

Torque wrench

The following tool is available through the Honda Tool and Equipment Program. On the iN, click on Service > Service Bay > Tool and Equipment Program, then enter the number under "Search." Or, call 888-424-6857.

Rivet Nut Tool, 6 mm (T/N 07AAE-000A100)

Illustration of the Trunk Drawer in the Vehicle

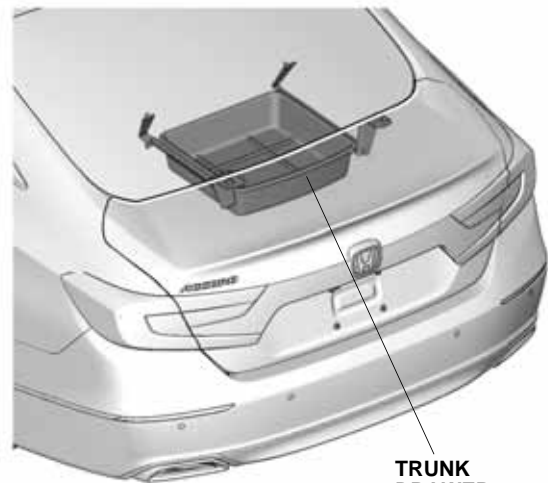

TRUNK DRAWER

QG21301AN

INSTALLATION

Customer Information: The information in this installation instruction is intended for use only by skilled technicians who have the proper tools, equipment, and training to correctly and safely add equipment to your vehicle. These procedures should not be attempted by “do-it-yourselfers.”

NOTE: Be careful not to damage the body.

1. Thread the rivet nut onto the mandrel of the 6 mm rivet nut tool as shown.

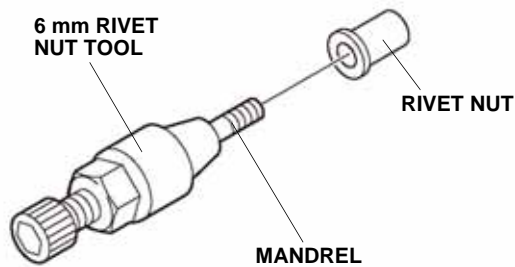

QEN0506AG

2. Insert the six rivet nuts into the six holes in the vehicle panel, and install the hex wrench on the 6 mm rivet nut tool.
NOTE: Make sure to insert the rivet nuts in the correct locations.

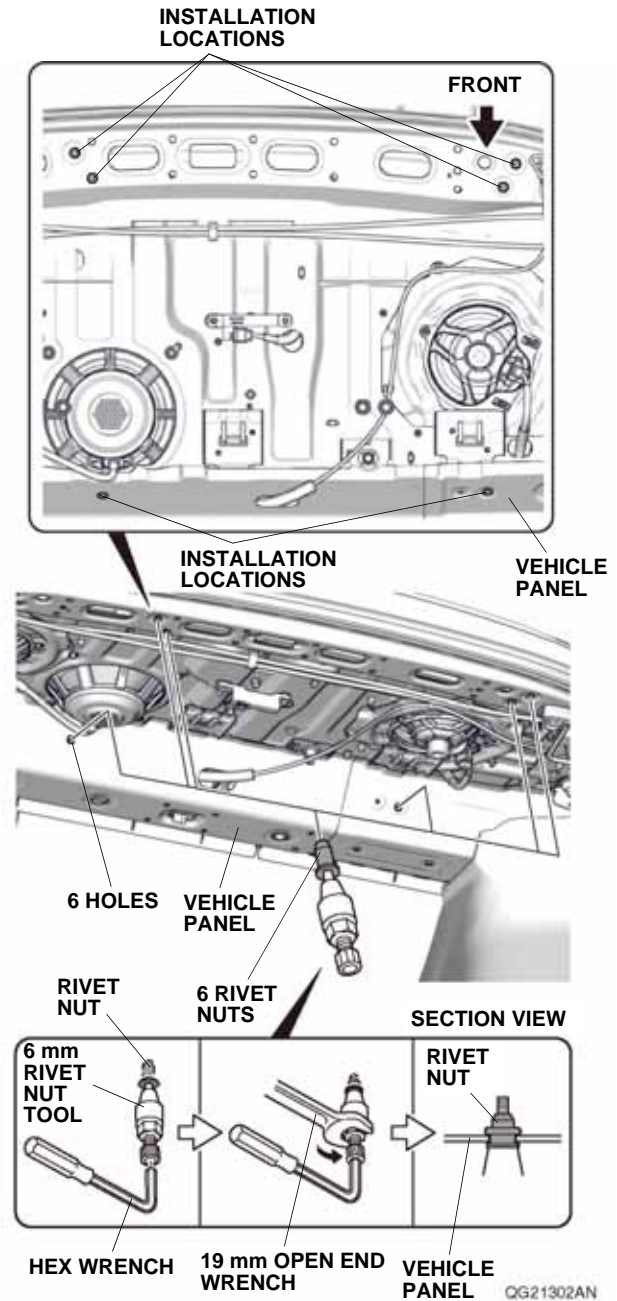

3. While holding the 6 mm rivet nut tool with the hex wrench, turn the 19 mm open end wrench counterclockwise to install the rivet nuts into the vehicle panel.
4. Remove the 6 mm rivet nut tool from the rivet nuts by turning the hex wrench counterclockwise.

5. Insert the trunk drawer into the left and right rails.
NOTE: Hold the ball bearing cages in place while inserting the inner rails.

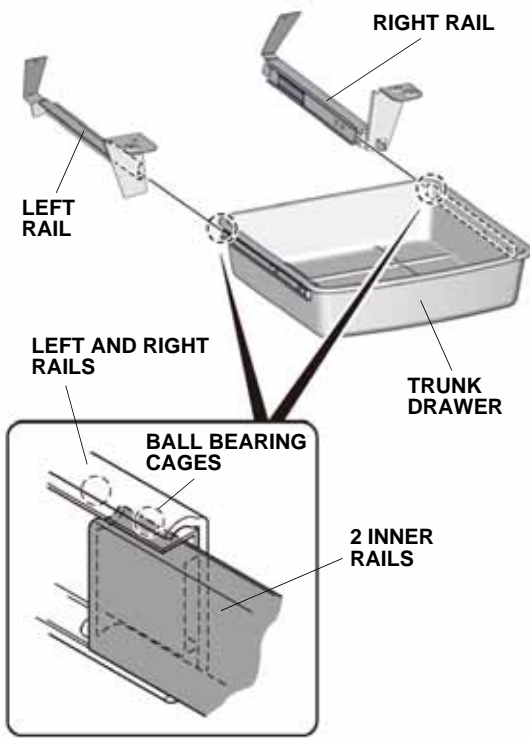

QG21304BN

6. Install the trunk drawer assembly with the six bolts supplied, and torque to 3.0 lb-ft (4.0 N-m).
NOTE: Hold the rails in place while torquing the bolts to prevent the rails from twisting.

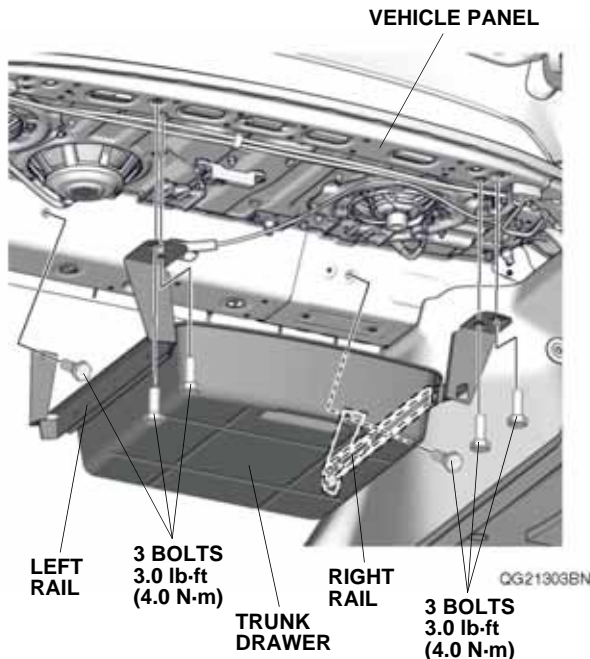

QG21303BN

7. Test the trunk drawer by pushing the yellow tab and pulling the trunk drawer open, using the handle at the bottom of the trunk drawer as shown.
- Complete one full open/close cycle to test the correct installation.
 - Trunk drawer should slide smoothly, and stop at the full open position.
 - Trunk drawer should click into the locked position when completely closed.

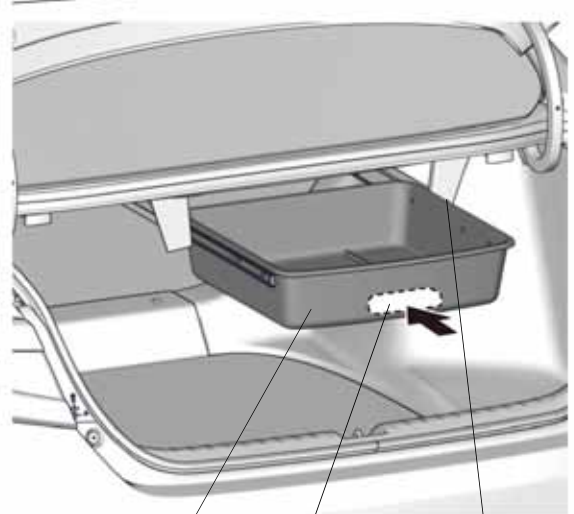
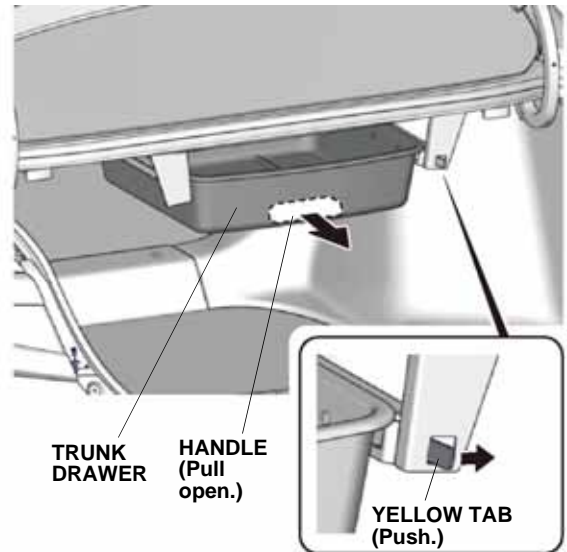

QG62319AN