



INSTALLATION INSTRUCTIONS

Accessory	Application	Publications No.
CARGO NET P/N 08L96-TVA-100	2019 ACCORD	VERSION 1
		Issue Date OCT 2018

PARTS LIST

Cargo net



2 Anchors



2 Bolts



2 Rivet nuts



4 Washers



2 Rings



2 Snaps



Accessory User's Information Manual



TOOLS AND SUPPLIES REQUIRED

19 mm Open end wrench

Drill

8 mm Drill bit

Eye protection (face shield, safety goggles, etc.)

Touch-up paint

File

Hex wrench

Masking tape

Ruler

The following tools are available through the Honda Tool and Equipment Program. On the iN, click on Service > Service Bay > Tool and Equipment Program, then enter the number under "Search." Or, call 888-424-6857.

- Rivet Nut Tool, 6 mm (T/N 07AAE-000A100)
- Plastic Trim Tool (T/N SILTRIMTL10)
- Trim Tool Set (T/N SOJATP2014)
- Deburring Tool (T/N DEBUR300)

Illustration of the Cargo Net in the Vehicle

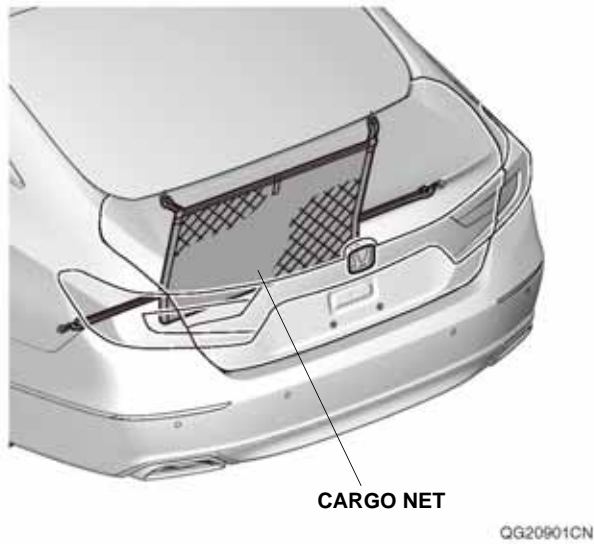

INSTALLATION

Customer Information: The information in this installation instruction is intended for use only by skilled technicians who have the proper tools, equipment, and training to correctly and safely add equipment to your vehicle. These procedures should not be attempted by “do-it-yourselfers.”

NOTE: Be careful not to damage the body.

Installing the Cargo Net

1. Open the trunk lid. Remove one clip from the left trunk side lining. Repeat on the right side of the vehicle.

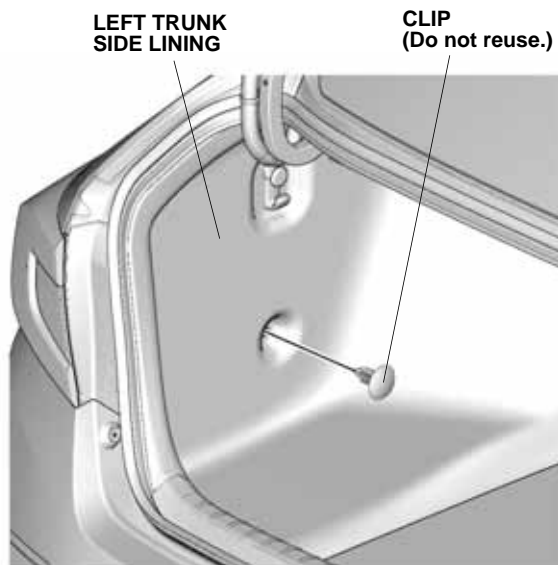

QG20902AN

2. While wearing eye protection, enlarge the clip hole in the left trunk side inner panel to 8 mm.
NOTE: Wrap masking tape around the drill bit 15 mm (0.59 in.) from the tip, or use a drill stop. Make sure to drill perpendicular to the left trunk side inner panel.

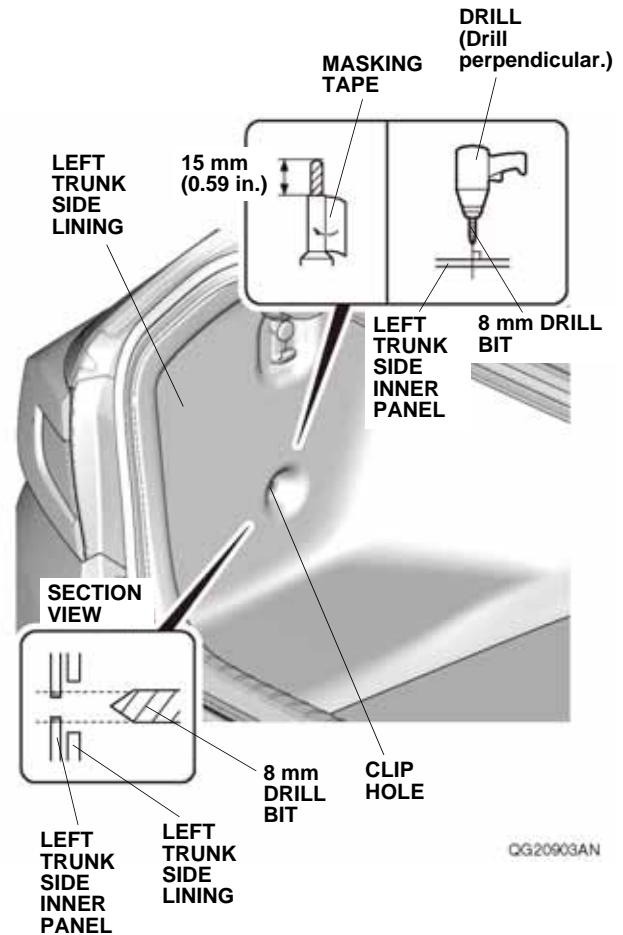

- Using a deburring tool, remove all burrs from the hole.

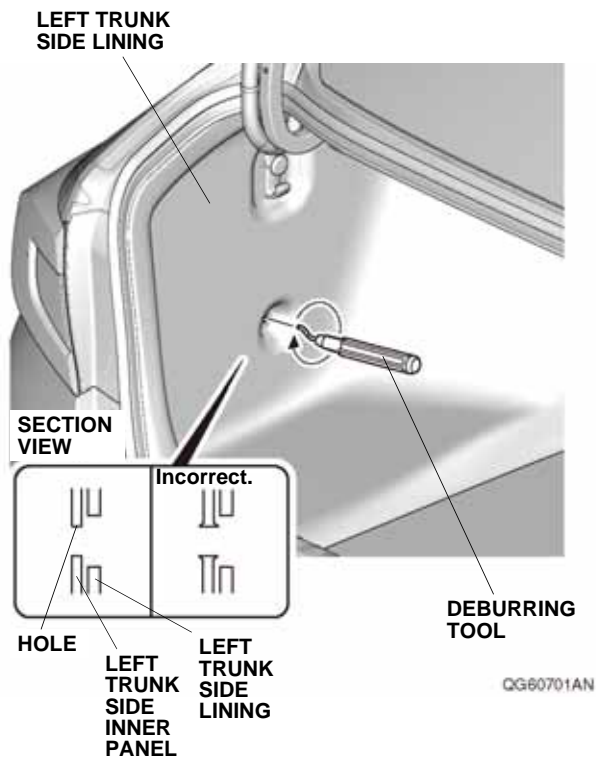

- Apply touch-up paint to the hole, and allow the touch-up paint to dry.
- Repeat steps 2 through 4 on the right side of the vehicle.
- Install the ring into the hole enlarged in the step 2. Repeat on the right side of the vehicle.

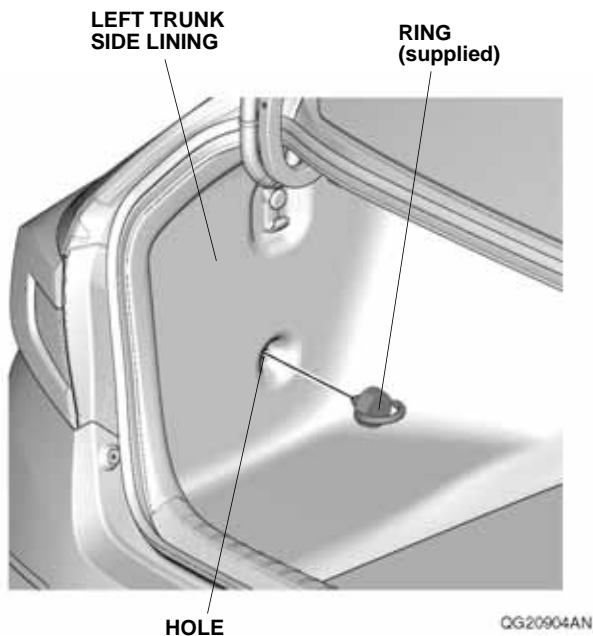

- Thread the rivet nut onto the mandrel of the 6 mm rivet nut tool as shown.

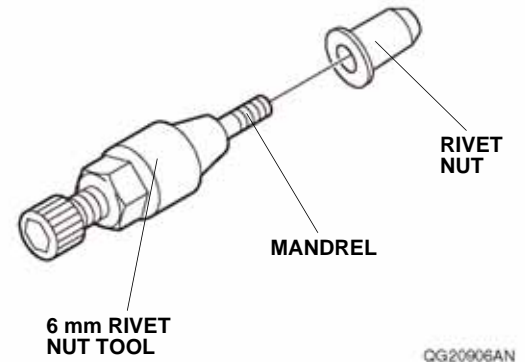

8. Insert the rivet nut into the hole in the vehicle panel, and install the hex wrench on the 6 mm rivet nut tool. **NOTE:** Make sure to insert the rivet nut in the correct position.

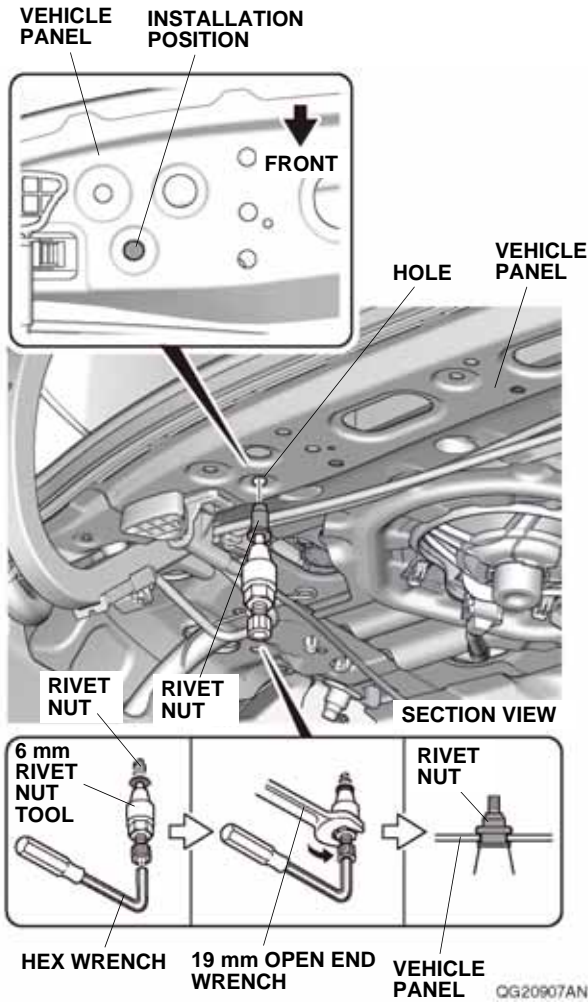

9. While holding the 6 mm rivet nut tool with the hex wrench, turn the 19 mm open end wrench counterclockwise to install the rivet nut into the vehicle panel.
10. Remove the 6 mm rivet nut tool from the rivet nut by turning the hex wrench counterclockwise.
11. Repeat steps 7 through 10 on the right side of the vehicle.

12. Thread each bolt into an anchor.

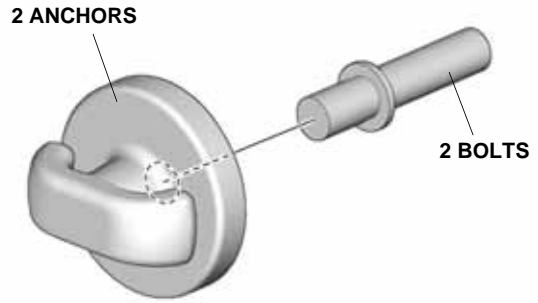

QG20905AN

13. Install one anchor into the rivet nut on the vehicle panel as shown. Repeat on the right side of the vehicle. **NOTE:** Adjust the arm of the anchor toward the cross direction.

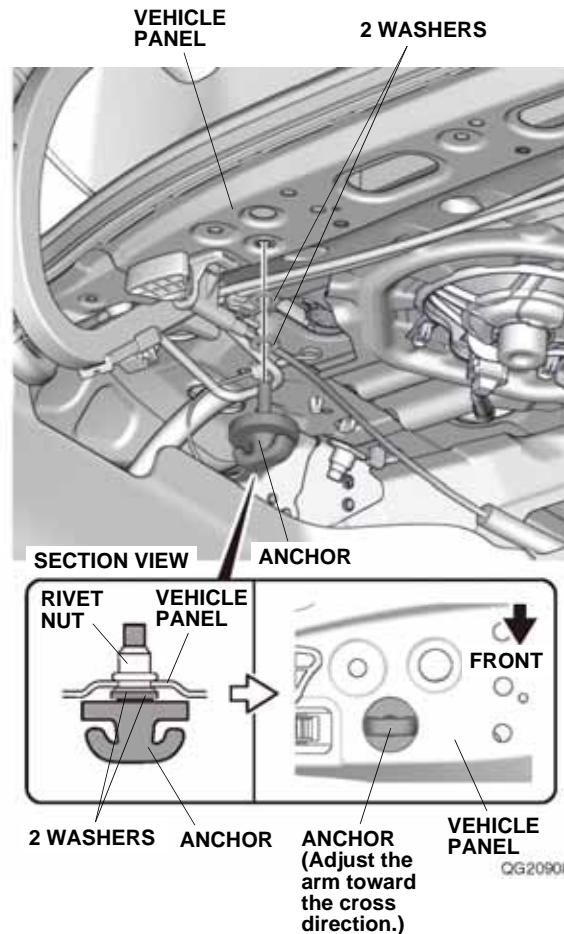

14. Install the cargo net to the anchors and rings as shown.

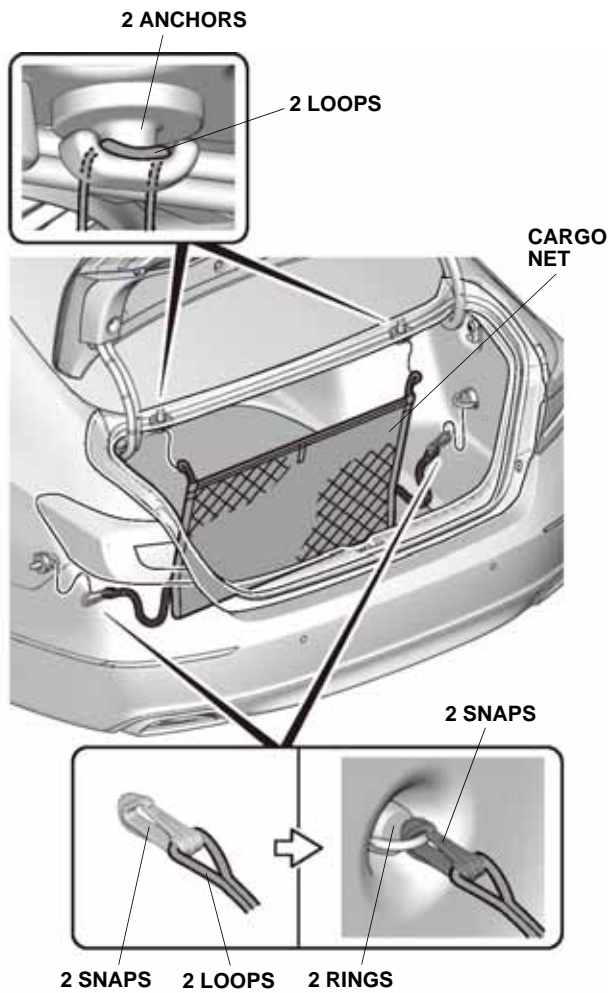

QG20909CN