



INSTALLATION INSTRUCTIONS

Accessory
SPLASH GUARDS
P/N 08P00-TVA-100

Application
2018 ACCORD

Publications No.
VERSION 2

Issue Date
MAR 2018

PARTS LIST

Left front splash guard



Right front splash guard



Left rear splash guard



Right rear splash guard



2 Spring nuts



Clip
(May not be used)



6 Self-tapping screws



TOOLS AND SUPPLIES REQUIRED

Phillips screwdriver

Stubby Phillips screwdriver

Pushpin

Ruler

Utility knife

The following tools are available through the Honda Tool and Equipment Program. On the iN, click on Service > Service Bay > Tool and Equipment Program, then enter the number under "Search." Or, call 888-424-6857.

- Trim Tool Set (T/N SOJATP2014)
- Plastic Trim Tool (T/N SILTRIMTL10)

Illustration of the Splash Guards on the Vehicle

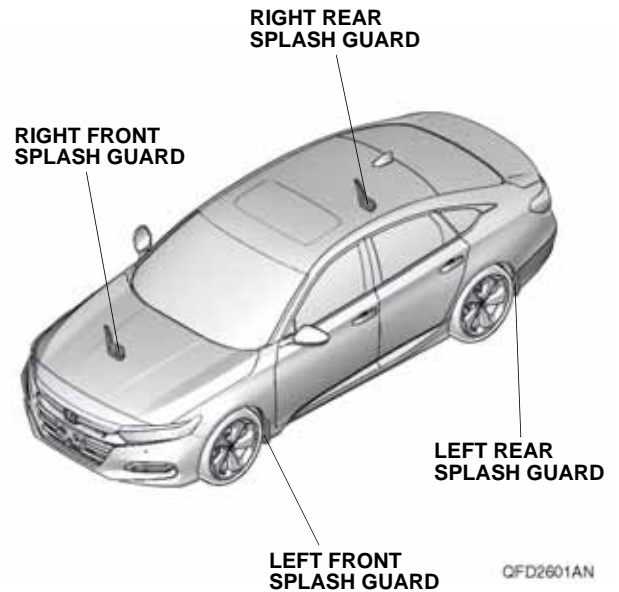

INSTALLATION

Customer Information: The information in this installation instruction is intended for use only by skilled technicians who have the proper tools, equipment, and training to correctly and safely add equipment to your vehicle. These procedures should not be attempted by “do-it-yourselfers.”

NOTE:

- Be careful not to damage the body paint finish.
- Clean the areas to be covered.

Installing the Front Splash Guards

1. Turn the steering wheel fully counterclockwise.

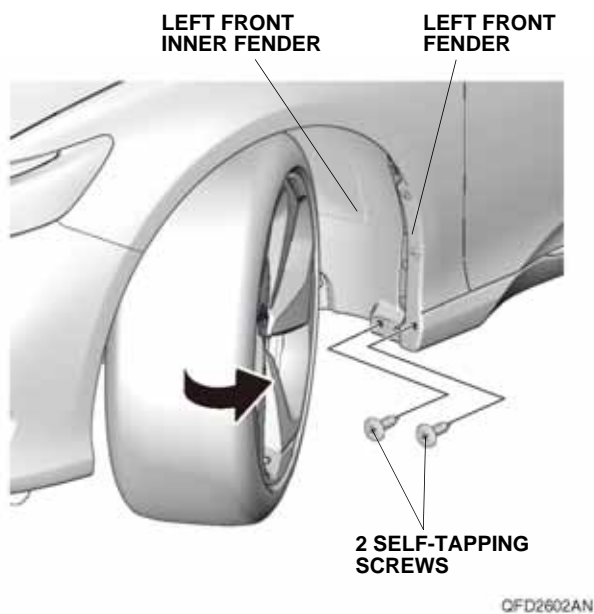

2. Remove the two self-tapping screws from the left front inner fender and left front fender.

3. Using a pushpin, pierce the center of the clip on the left front fender.
NOTE: Make sure to pierce the clip perpendicular.



- Loosely install the left front splash guard with one of the self-tapping screws supplied and the two self-tapping screws removed in step 2.

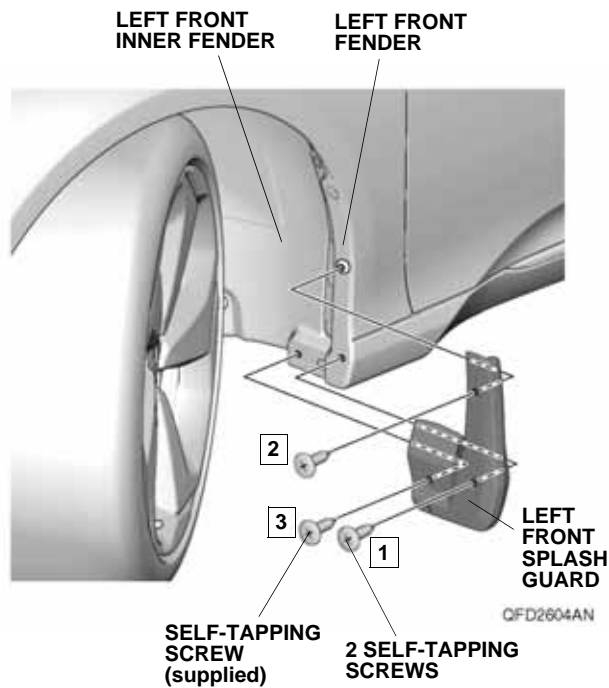

- While holding the left front splash guard in-place, tighten the three self-tapping screws in the order shown.
NOTE: Make sure there are no gaps between the guard and the vehicle body. If there is a gap, loosen the self-tapping screws, hold the splash guard against the body, and tighten the screws.
- Turn the steering wheel fully clockwise, and repeat steps 2 through 5 on the right side of the vehicle.

Installing the Rear Splash Guards

- Remove the two self-tapping screws and one clip from the rear bumper.
NOTE: Do not reuse the clip for the hybrid models.

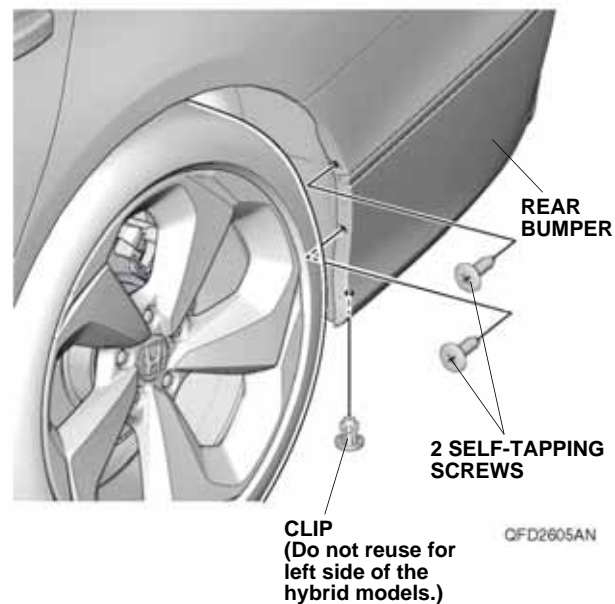

8. Locate the two dimples. Using a pushpin, pierce the rear bumper at the dimples.
NOTE: Make sure to pierce the rear bumper perpendicular.

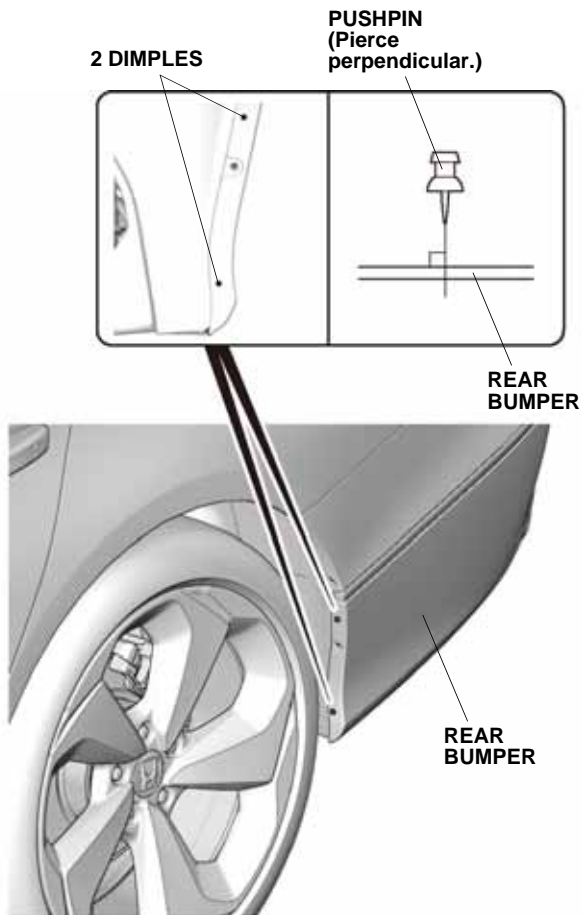

QFD2606AN

9. Pull away the rear bumper. Using a utility knife, cut off the left rear inner fender at the measurements shown.

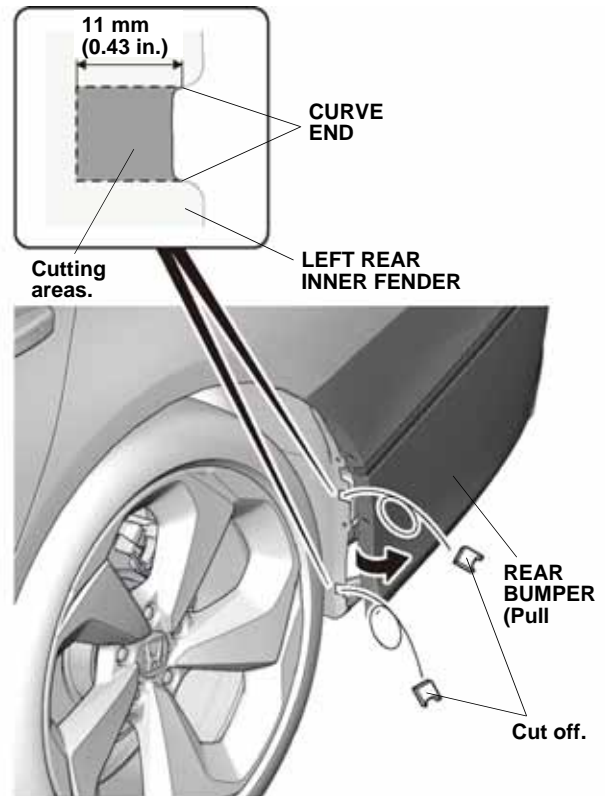

QFD2607BN

10. Install the rear bumper back into its original position with the two self-tapping screws removed in step 7.

11. Install one spring nut to the rear bumper as shown.
NOTE: Make sure to install the spring nut in the correct position and orientation.

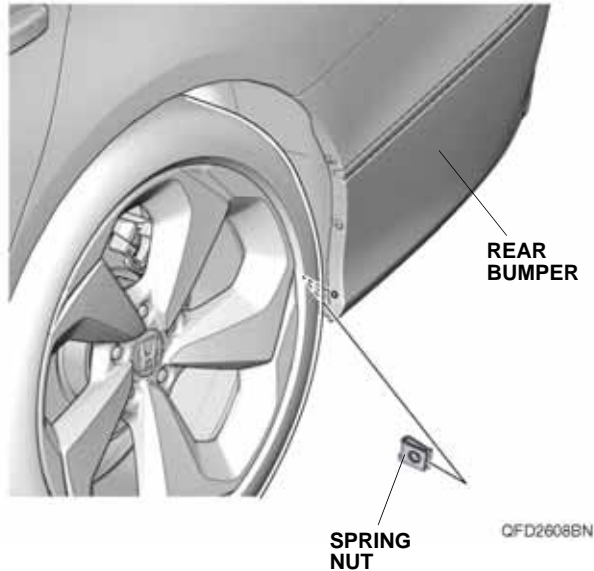

Hybrid models, go to step 13.

12. Install the left rear splash guard to the rear bumper with the two self-tapping screws supplied and the clip removed in step 7 as shown.
Go to step 14.
NOTE: Make sure there are no gaps between the left rear splash guard and vehicle body. If there is a gap, loosen the self-tapping screws, hold the splash guard against the body, and tighten the screws.

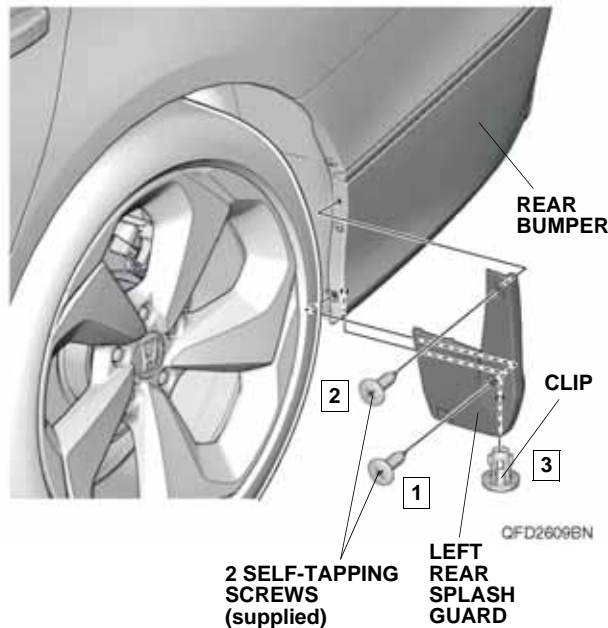

Hybrid models

13. Install the left rear splash guard to the rear bumper with the two self-tapping screws and one clip supplied, in the order shown. For the right side, use the two self-tapping screws supplied and one clip removed in step 7.
NOTE: Make sure there are no gaps between the rear splash guard and vehicle body. If there is a gap, loosen the self-tapping screws, hold the splash guard against the body, and tighten the screws.

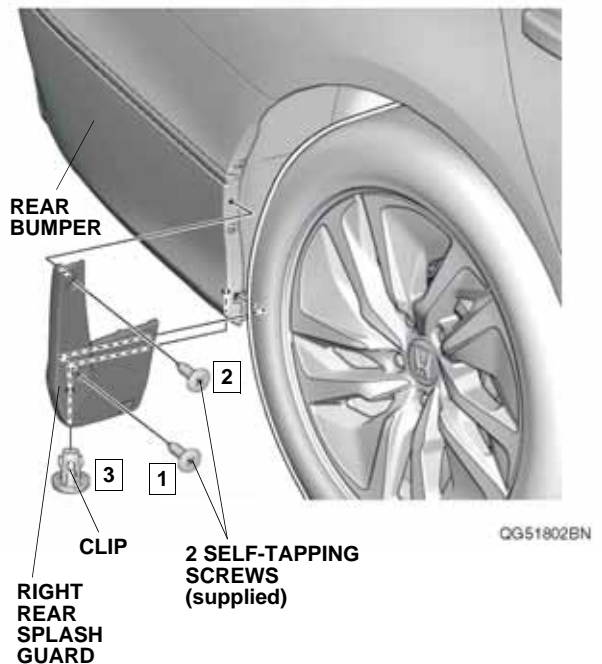
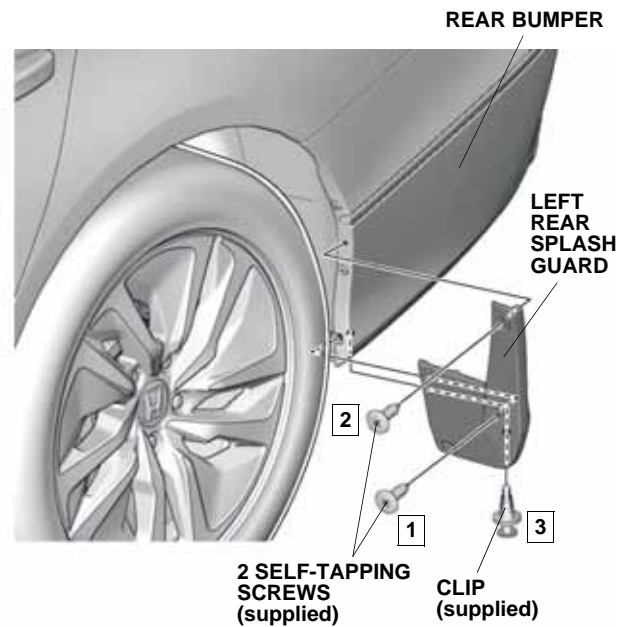

14. Repeat steps 7 through 13 on the right side of the vehicle.