



## INSTALLATION INSTRUCTIONS

Accessory  
REAR UNDER TRIM

Application  
2018 ACCORD

Publications No.  
VERSION 1

Issue Date  
OCT 2017

### PARTS LIST

Rear Under Trim Kit  
P/N 08F24-TVA-100

Rear under trim



4 Clips



3 Alcohol wipes  
(Some may not be used)



Rear Under Accent Trim Kit  
P/N 08F24-TVA-100A  
P/N 08F24-TVA-100B

Rear under accent trim



2 Self-tapping screws



2 Washers



Alcohol wipe



### TOOLS AND SUPPLIES REQUIRED

Phillips screwdriver

5 mm Hex wrench

Pushpin

Drill

File

10 mm Open end wrench

Masking tape

3 mm, 6 mm, 8 mm, and 10 mm Drill bits

Eye protection (face shield, safety goggles, etc.)

Blanket

Ruler

*The following tools are available through the Honda Tool and Equipment Program. On the iN, click on Service > Service Bay > Tool and Equipment Program, then enter the number under "Search." Or, call 888-424-6857.*

- Trim Tool Set (T/N SOJATP2014)
- Plastic Trim Tool (T/N SILTRIMTL10)
- Rubber Roller (T/N MHLE54D)

### Illustration of the Rear Under Trim on the Vehicle

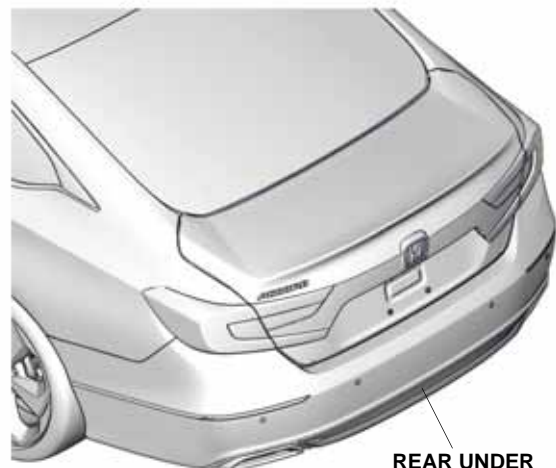

REAR UNDER TRIM

QFD2001AA

## INSTALLATION

**Customer Information:** The information in this installation instruction is intended for use only by skilled technicians who have the proper tools, equipment, and training to correctly and safely add equipment to your vehicle. These procedures should not be attempted by “do-it-yourselfers.”

### NOTE:

- Be careful not to damage the body paint finish.
  - This kit should be installed only if the ambient air temperature is 15°C (60°F) or above.
  - Clean the areas to be covered.
  - To allow the adhesive to cure, do not wash the vehicle for 24 hours. Make sure the customer is aware of this.
1. Disconnect the negative cable from the battery.
  2. Remove the rear bumper:
    - Apply masking tape as shown.

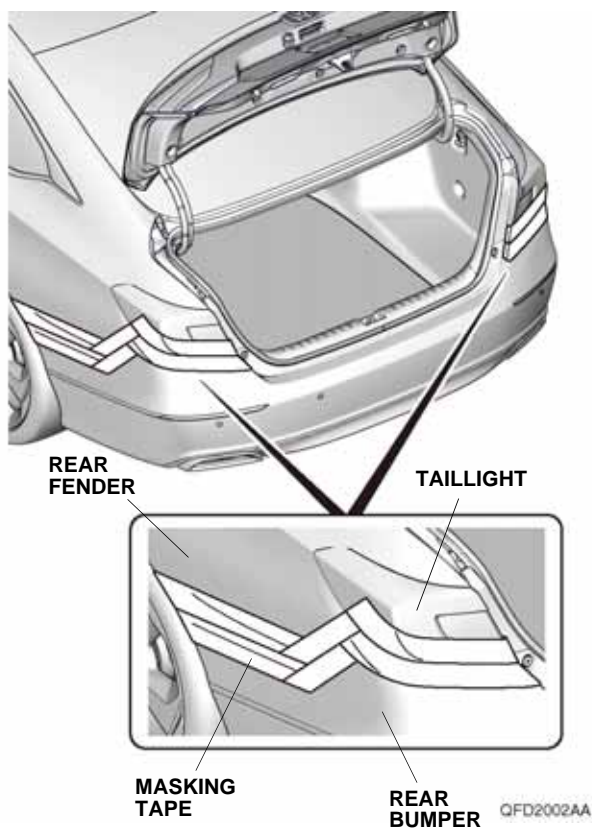

- Remove the six self-tapping screws, four clips, and two bolts as shown.

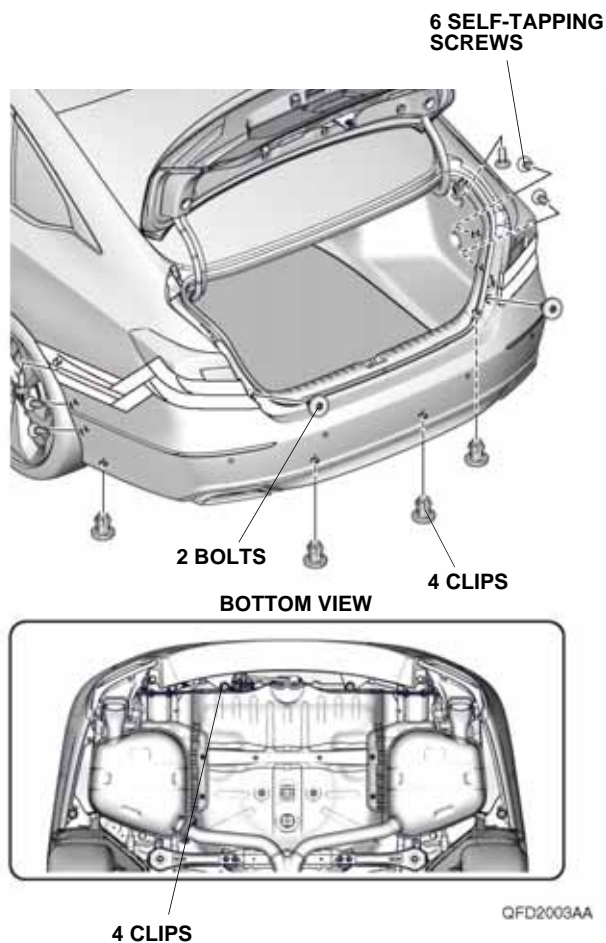

- With the help of an assistant, release the nine retaining tabs on each side.

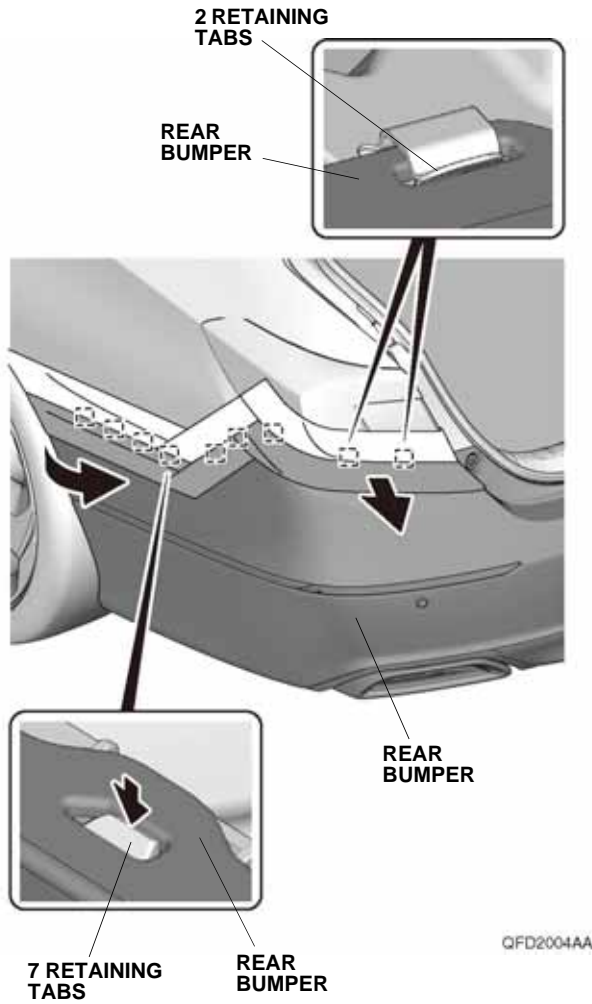

- With the help of an assistant, remove the rear bumper and unplug the vehicle connector (if equipped).
- Place the rear bumper on a blanket.

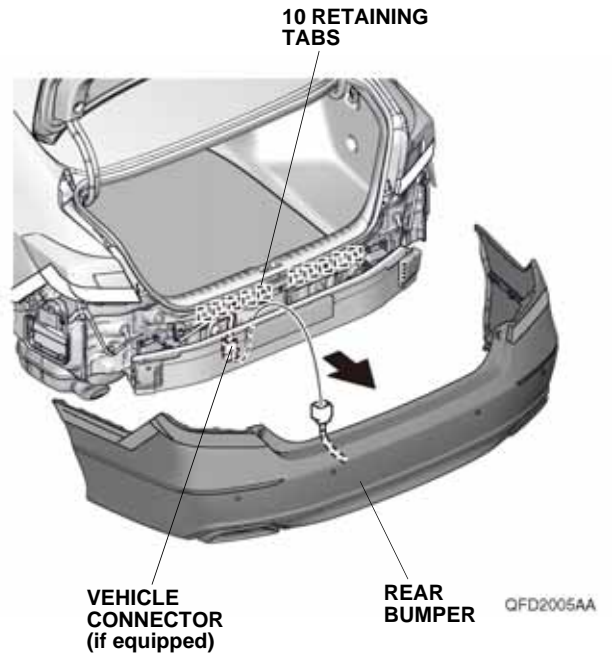

3. Mark the inside of the rear bumper:
- Locate the six scribe marks on the inside of the rear bumper.
  - Using a pushpin, pierce the rear bumper at the six scribe marks.
- NOTE: There are several markings on the inside of the rear bumper. Before piercing the rear bumper, verify you have the correct locations. Make sure to pierce the scribe marks perpendicular to the rear bumper.

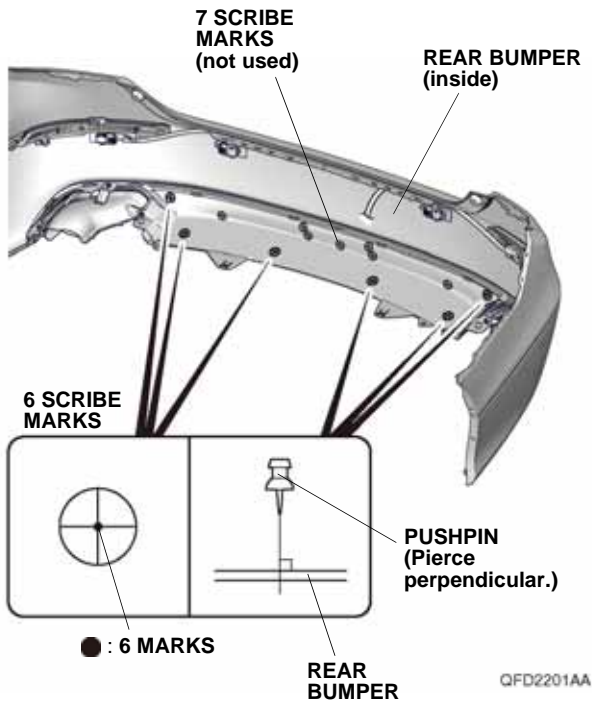

4. While wearing eye protection, drill the six pierced marks to 8 mm. First, drill with a 3 mm drill bit, then follow with a 6 mm drill bit, and finish with an 8 mm drill bit.
- NOTE: Wrap masking tape around drill bits 10 mm (0.39 in.) from the tip, or use a drill stop. Make sure to drill perpendicular to the rear bumper.

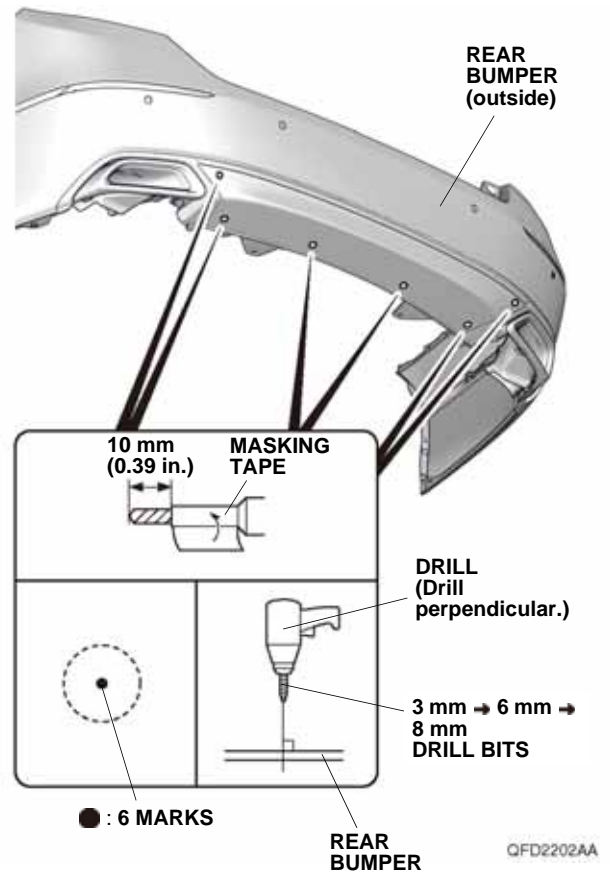

5. While wearing eye protection, enlarge the four drilled holes on the rear bumper to 10 mm with a 10 mm drill bit.

NOTE: Wrap masking tape around drill bit 10 mm (0.39 in.) from the tip, or use a drill stop. Make sure to drill perpendicular to the rear bumper. To ensure proper clip engagement, be sure to remove any burrs.

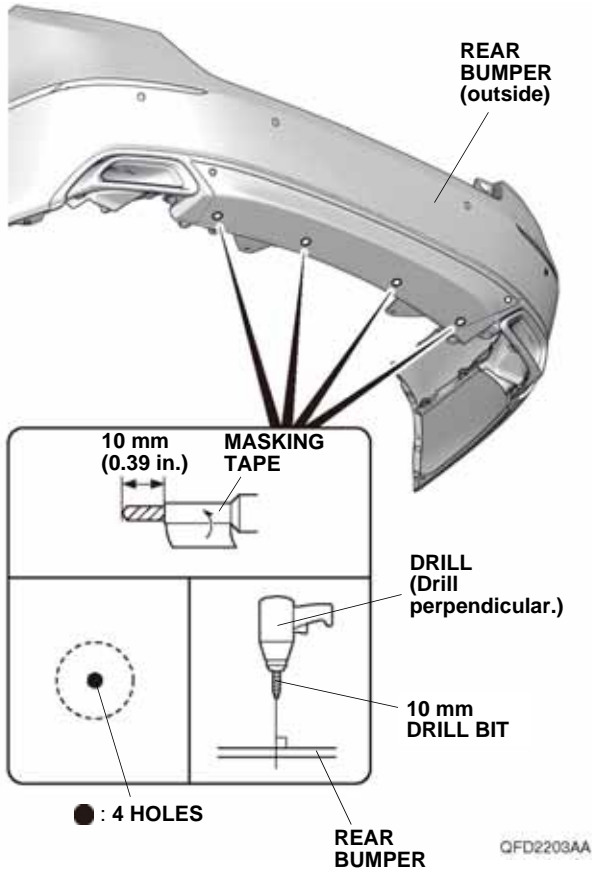

6. Using an alcohol wipe, thoroughly clean the rear under trim where the rear under accent trim will attach.

NOTE: Any remaining oil or dirt on the rear under trim surface will affect the adhesive tape effectiveness, which could cause gaps or lifting of the rear under accent trim.

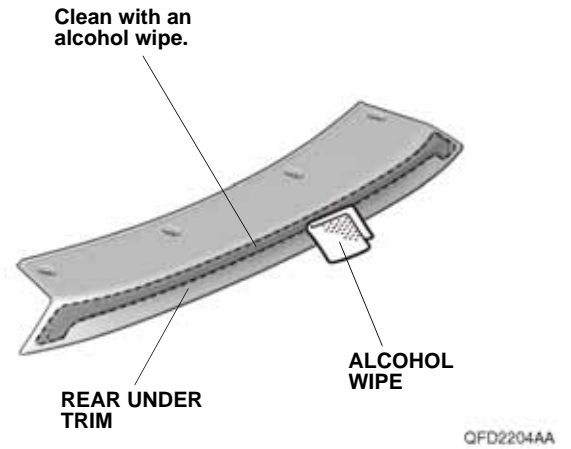

7. Peel back the adhesive backings, and tape them to the front surface of the rear under accent trim with masking tape. Remove the remaining adhesive backings.

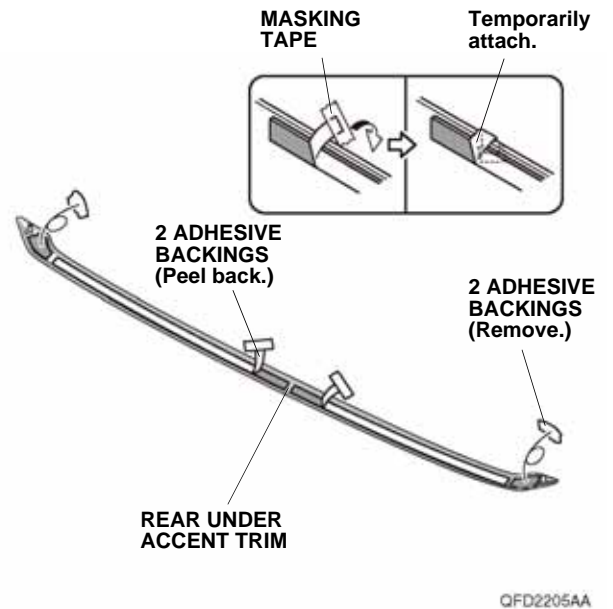

8. Line up the rear under accent trim with the rear under trim, and attach it as shown.

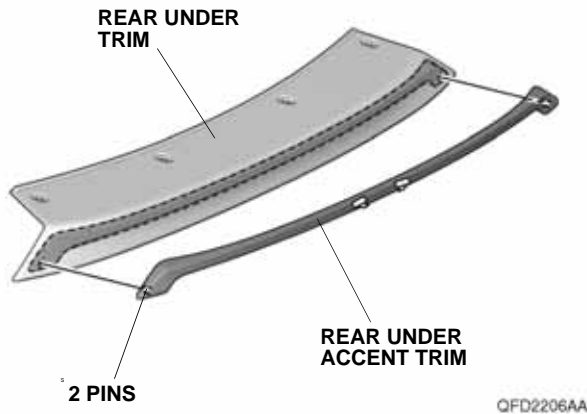

9. While applying light pressure against the rear under accent trim, carefully remove the taped adhesive backings.

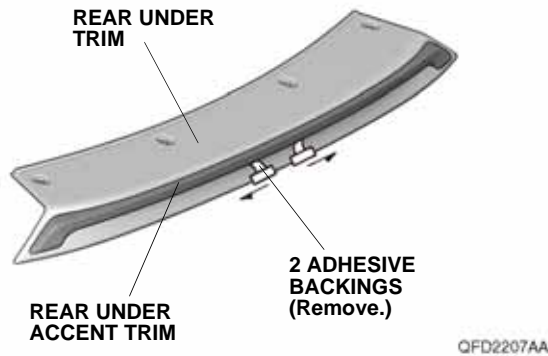

10. Using a rubber roller, apply firm pressure against the rear under accent trim and roll from one end to the other.  
NOTE: Apply firm pressure, especially at the ends.

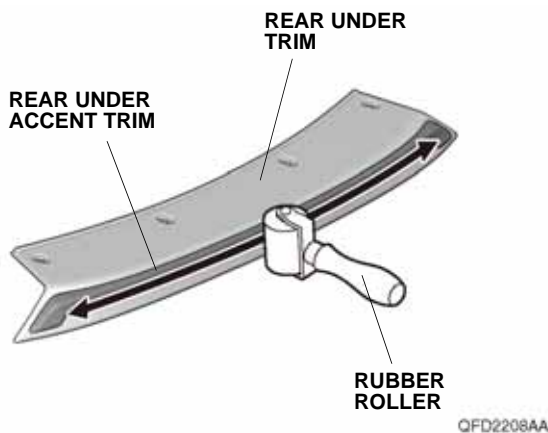

11. Using an alcohol wipe, thoroughly clean the rear bumper where the rear under trim will attach.  
NOTE: Any remaining oil or dirt on the rear bumper surface will affect the adhesive tape effectiveness, which could cause gaps or lifting of the rear under trim.

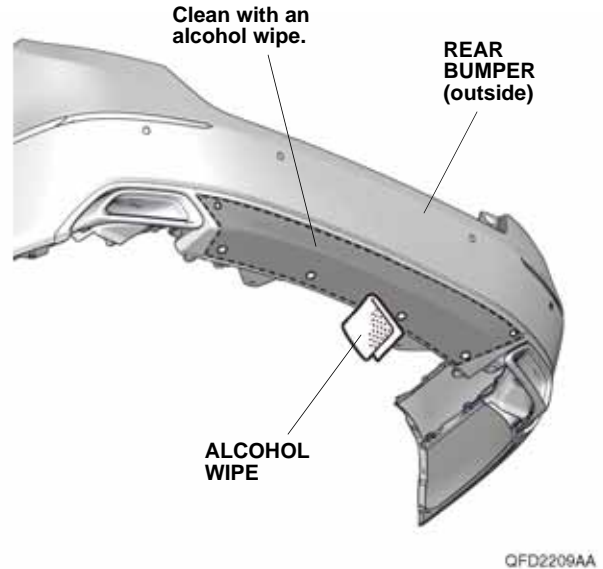

12. Peel back the adhesive backings, and tape them to the front surface of the rear under trim with masking tape.

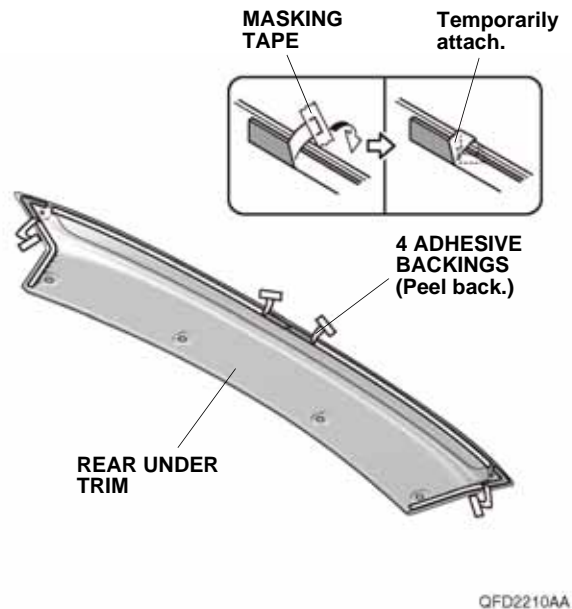

13. Line up the rear under trim with the rear bumper as shown. Loosely install the rear under trim to the rear bumper with four clips, two washers, and two self-tapping screws.

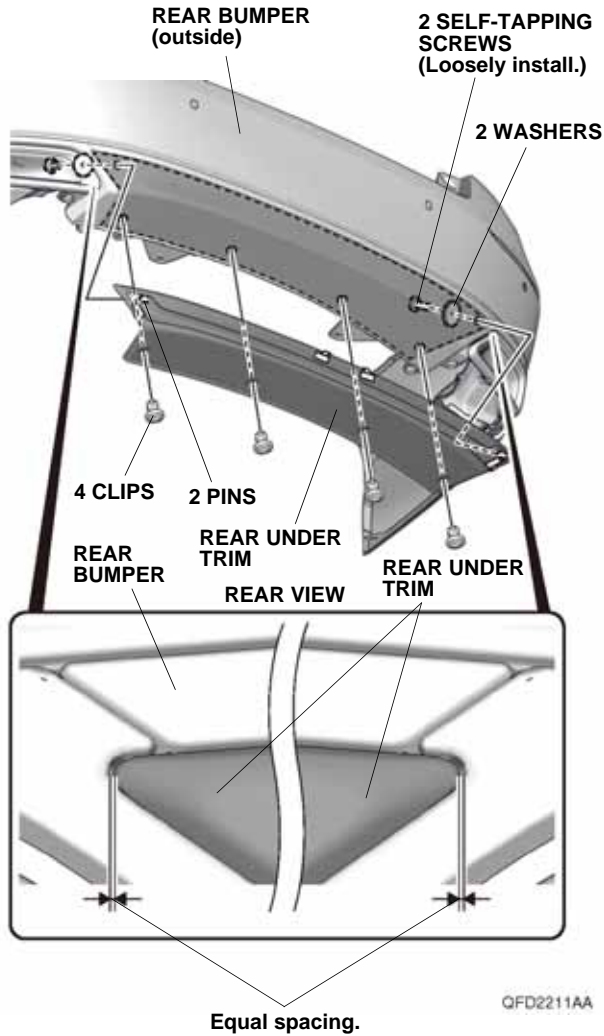

14. While applying light pressure against the rear under trim, carefully remove the taped adhesive backings.

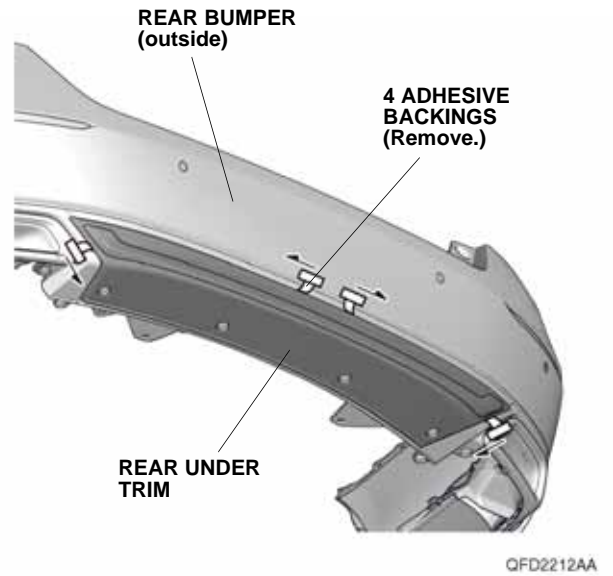

15. Using a rubber roller, apply firm pressure against the rear under trim and roll from one end to the other. NOTE: Apply firm pressure, especially at the ends.

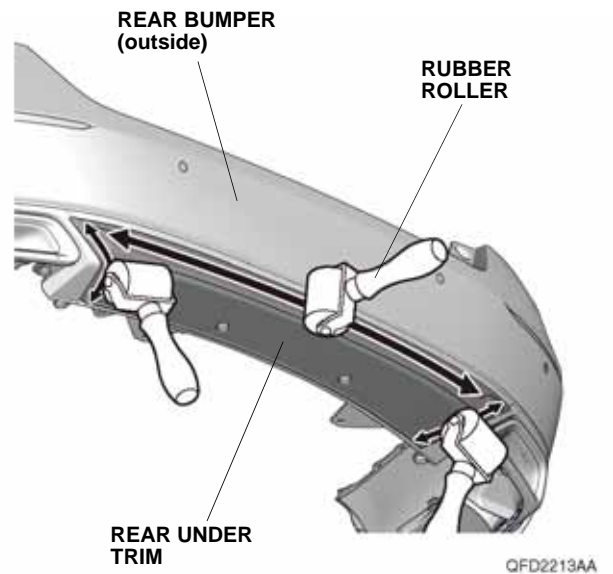

16. Tighten the two self-tapping screws loosely installed in step 13.

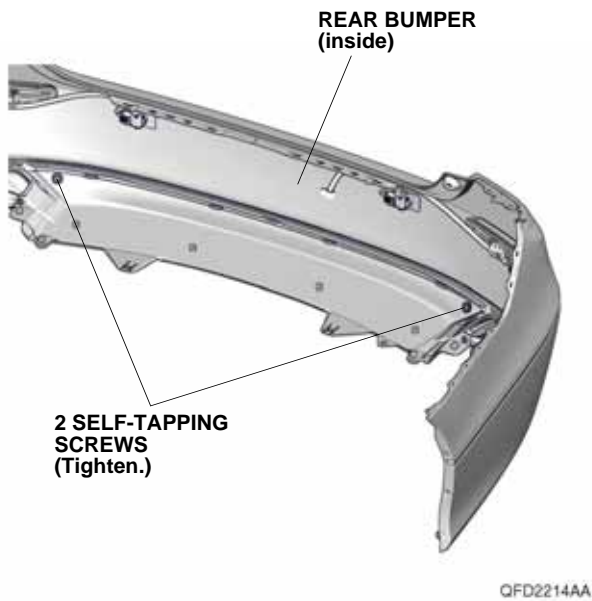

17. Check that all wire harnesses are routed properly and all connectors are plugged in.
18. Install all removed parts.
19. Connect the negative cable to the battery.
20. Press and hold the audio unit power button for 2 seconds to restore the audio and navi (if equipped) system functions.
21. Set the clock on vehicles without navigation.
22. If necessary, restore the systems back to normal operation as described in the service information.