



INSTALLATION INSTRUCTIONS

Accessory
FOGLIGHT
P/N 08V31-SVA-100A

Application
2007 CIVIC SI

Publications No.
All 33486
Issue Date
AUG 2006

PARTS LIST

Right fog light

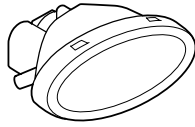

Left fog light



Right bracket

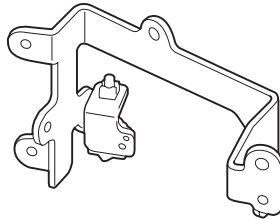

Left bracket

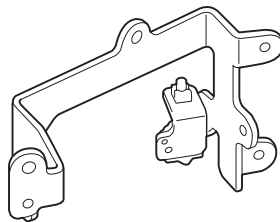

Switch harness

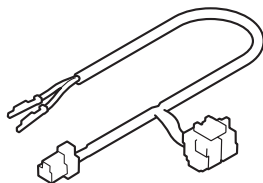

Fog light harness

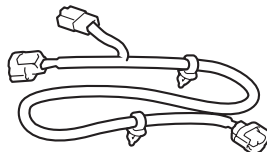

Sub harness

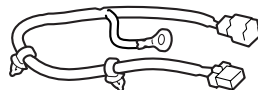

Switch

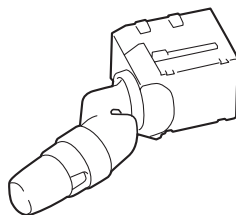

5 Wire ties

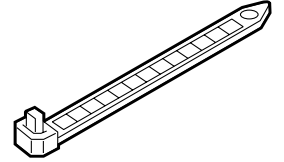

Clip



4 Stepped screws



2 Washer screws



6 Self-tapping screws



Fuse (20 A)

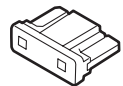

Relay

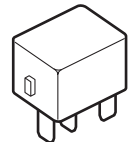

5 Wire ties with clips

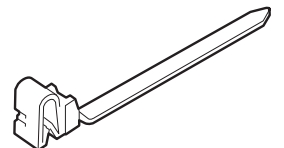

Template

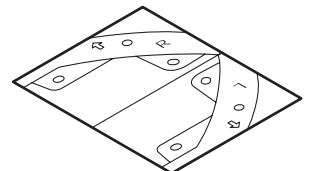

Ground bolt



TOOLS AND SUPPLIES REQUIRED

Phillips screwdriver
Flat-tip screwdriver
Ratchet
10 mm Socket
Drill
3 mm and 10 mm Drill bit
Pushpin
Utility knife
Gloves
Eye protection (face shield, safety goggles, etc.)
File
Masking tape
Scissors
Blanket
Shop towel
5 mm Hexagon wrench

Illustration of Fog Lights installed on the vehicle

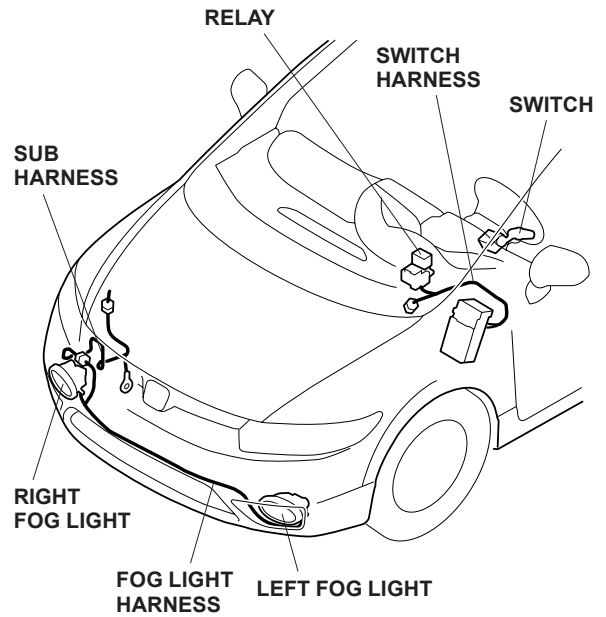

INSTALLATION

Customer Information: The information in this installation instruction is intended for use only by skilled technicians who have the proper tools, equipment, and training to correctly and safely add equipment to your vehicle. These procedures should not be attempted by "do-it-yourselfers."

1. Make sure you have the anti-theft code for the radio, then write down the frequencies for the preset buttons.
2. Disconnect the negative cable from the battery.
3. Remove the radiator cover (four clips).

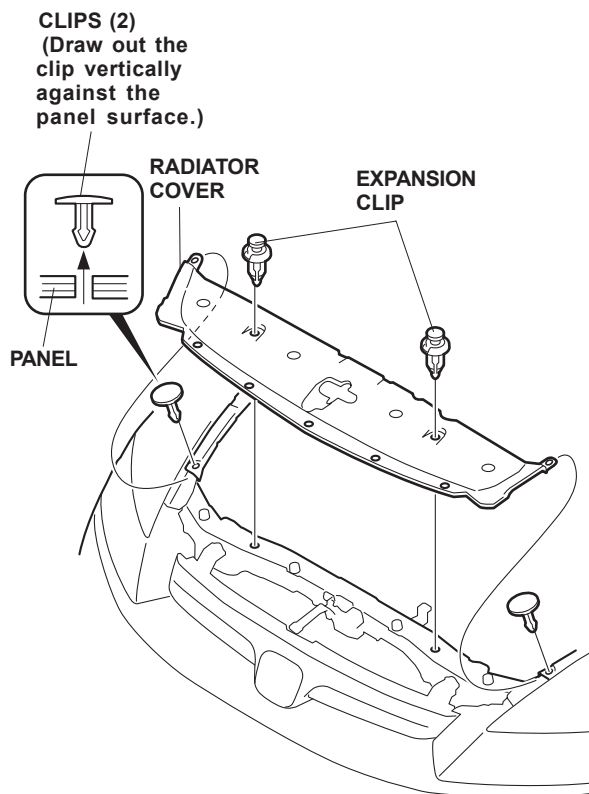

4. With the help of an assistant, remove the front bumper (six clips, two screws and four bolts). Set the front bumper on a blanket.

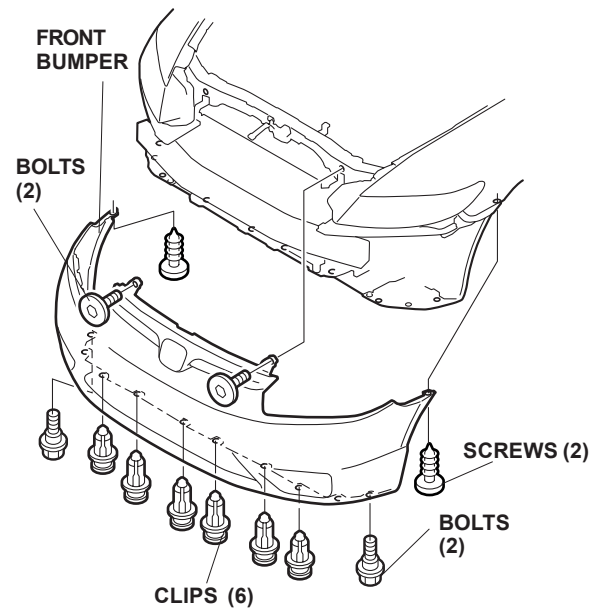

5. Apply masking tape to the front bumper around the left fog light area.

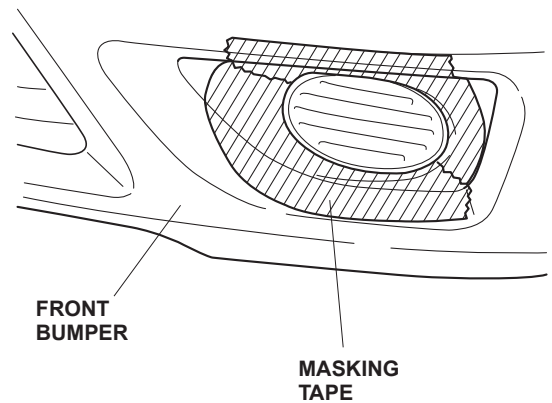

- Using a utility knife, and working from the front of the bumper, carefully cut out the front bumper in the area shown. Take care not to damage the front bumper. Remove any burrs from the edges of the hole.

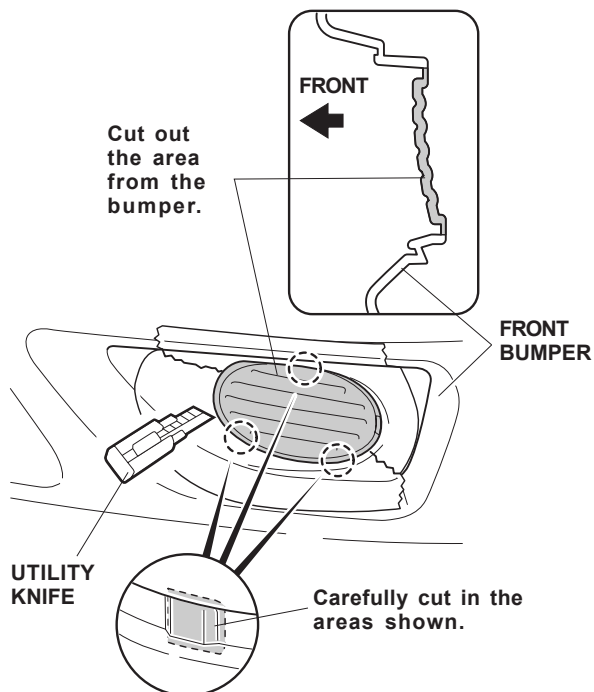

- Repeat steps 5 and 6 to cut the bumper for the right fog light.
- Using scissors, cut out the template. The template "L" is the mirror image of the template "R."

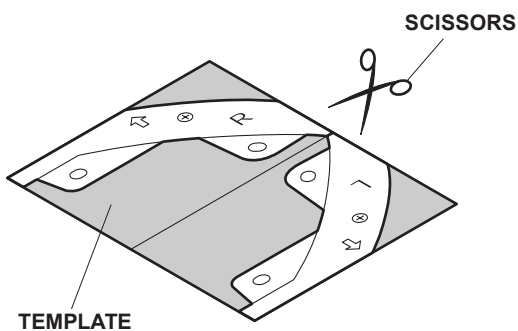

- Tape the template marked "L" to the inside of the front bumper below the left fog light opening. Using a pushpin, pierce the bumper through the mark in the template.

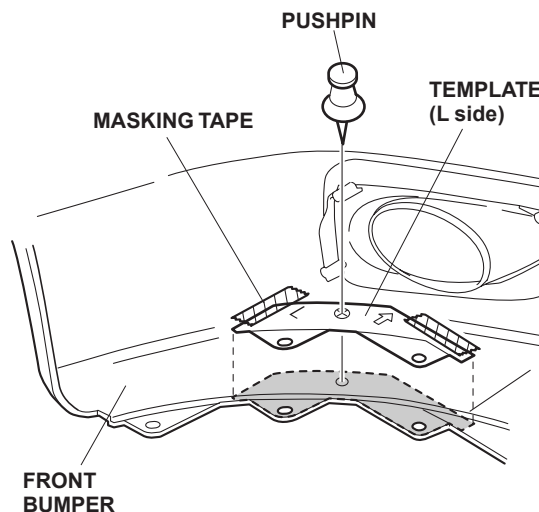

- While wearing eye protection, drill a 10 mm hole through the bumper at the marked location. First drill with a 3 mm drill bit and finish with a 10 mm drill bit.

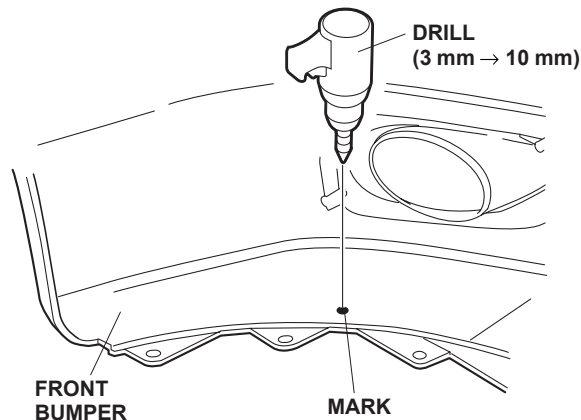

- Repeat steps 9 and 10 to mark and drill the right side of the front bumper.

- Position the left bracket on the left fog light, and install the two stepped screws and one washer screw. Tighten the screws securely.

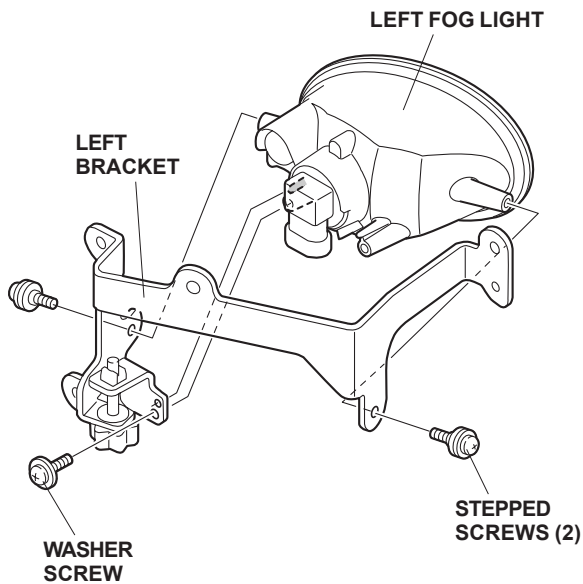

- Inside the front bumper, slide the left fog light into the cutout you made, and secure it with three self-tapping screws.

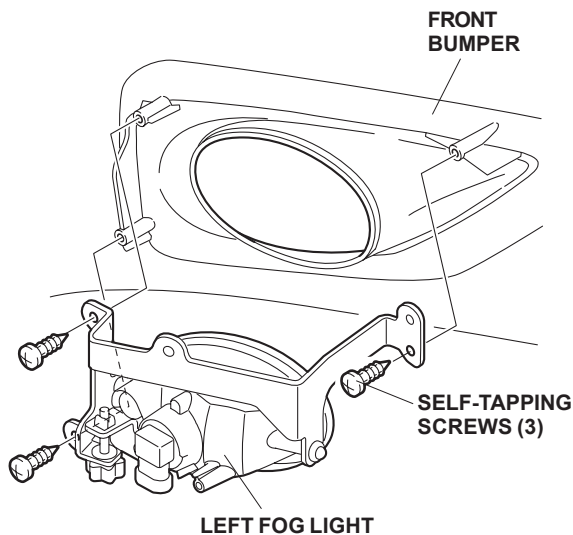

- Repeat steps 12 and 13 to install the right fog light.

- Route the fog light harness along the inside of the front bumper, and plug in the 2-pin connectors into the fog lights.

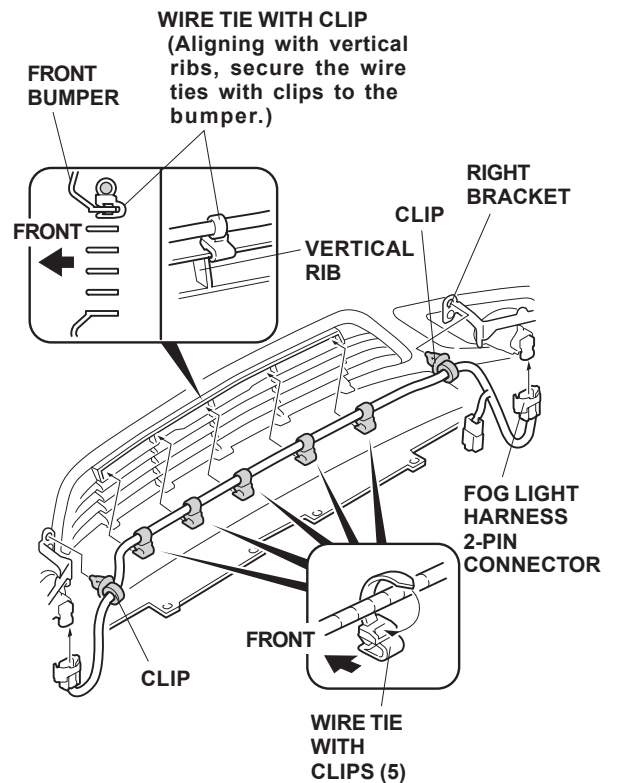

- Secure the clips attached to the fog light harness to the left and right fog light brackets.
- Loosely install five wire ties with clip on the fog light harness.
- Align the five wire ties with clips with the vertical ribs of the front bumper as shown, and tighten the five wire ties with clips securely.

19. Slide the clip onto the 2-pin connector of fog light harness and secure the connector to the right bracket.

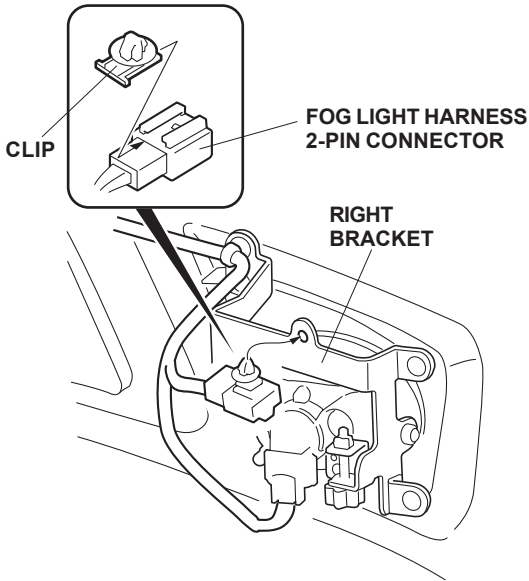

20. Remove one bolt from the washer reservoir tank and loosen the two bolts.

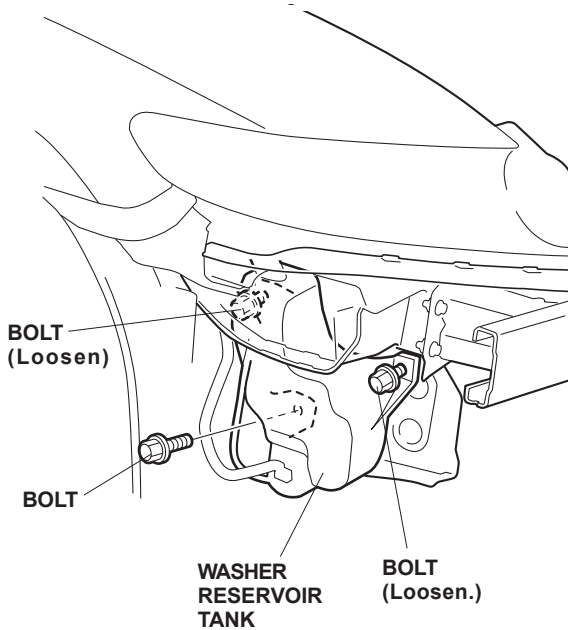

21. Locate the 1-pin connector blue-taped to the vehicle harness and remove the blue tape to free the 1-pin connector. Plug the 1-pin connector you just freed into the 1-pin connector from the sub harness.

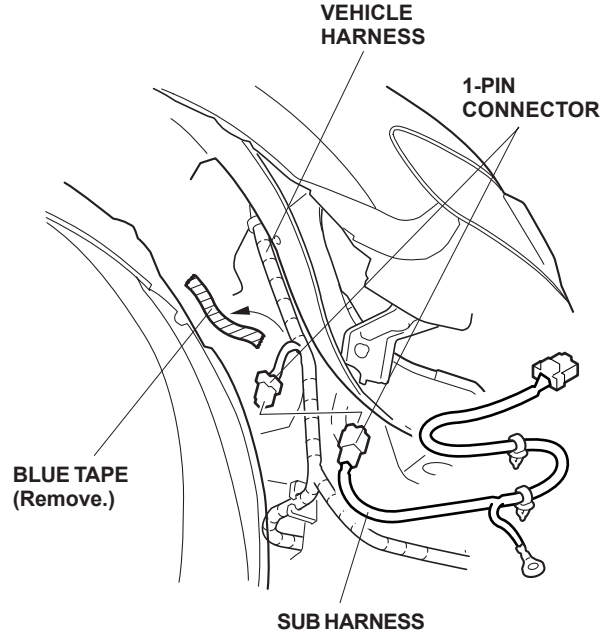

22. Route the sub harness between the washer reservoir tank and vehicle panel and route it as shown.

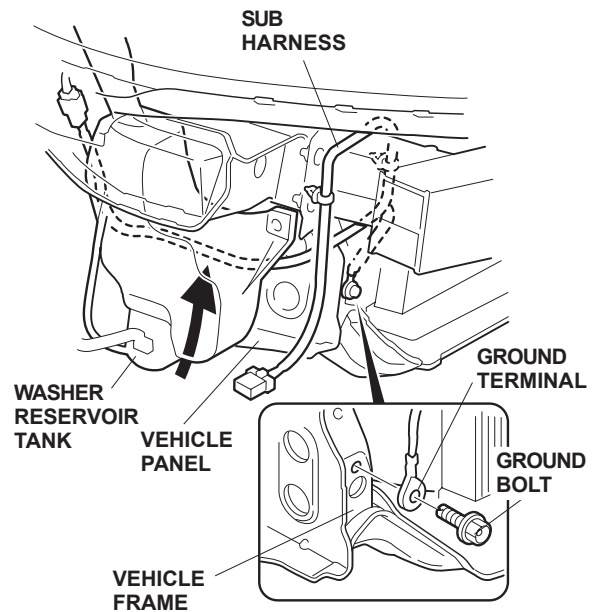

23. Secure the sub harness ground terminal to the vehicle frame using a ground bolt.

24. Secure the two clips from the sub harness to the vehicle frame. Secure the sub harness to the vehicle harness using two wire ties.

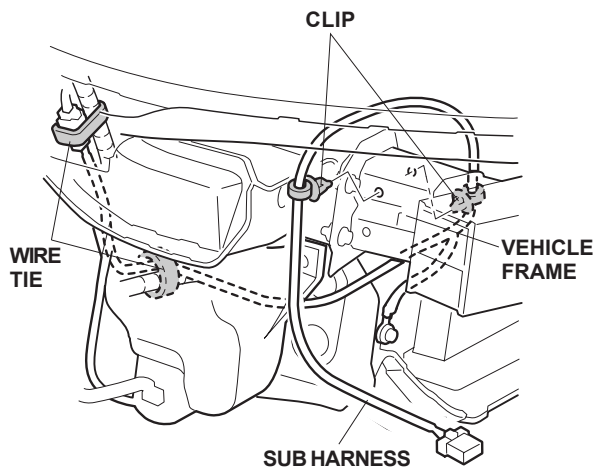

25. Reinstall the washer reservoir tank.
 26. Plug the 2-pin connector from the sub harness into the 2-pin connector of the fog light harness.

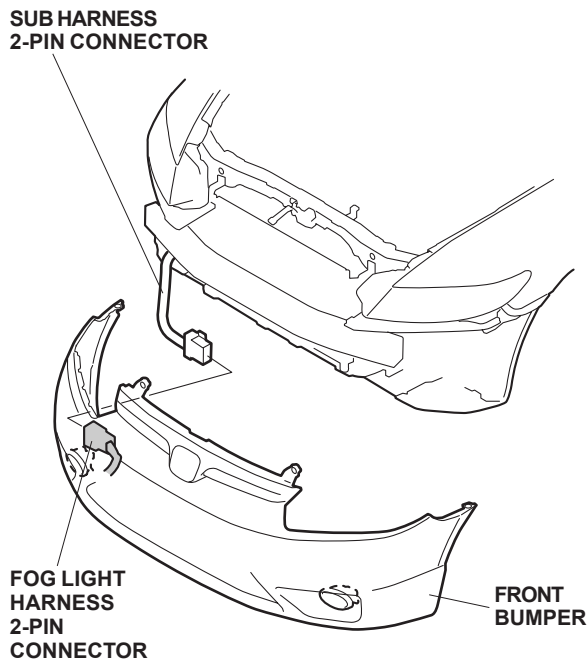

27. Reinstall the front bumper.

28. Remove the cover from the trunk lid/fuel fill door opener (six retaining tabs), and remove one self-tapping screw.

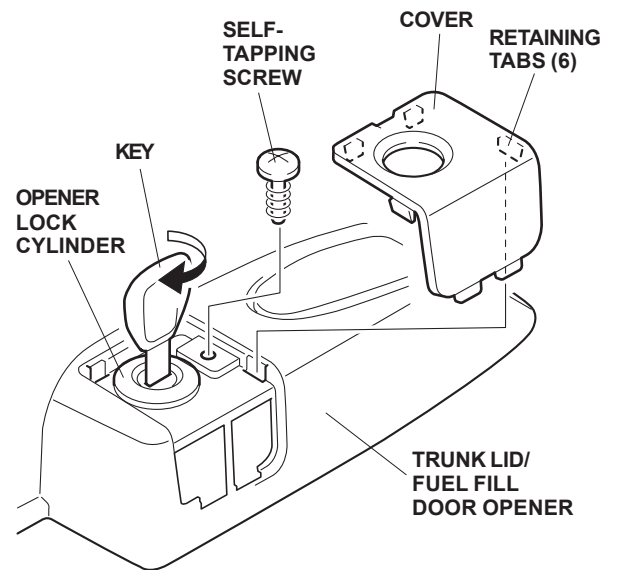

29. Using the ignition key, unlock the opener.
 30. Raise the front side of the left front door sill trim (six clips, retaining tab and hook).

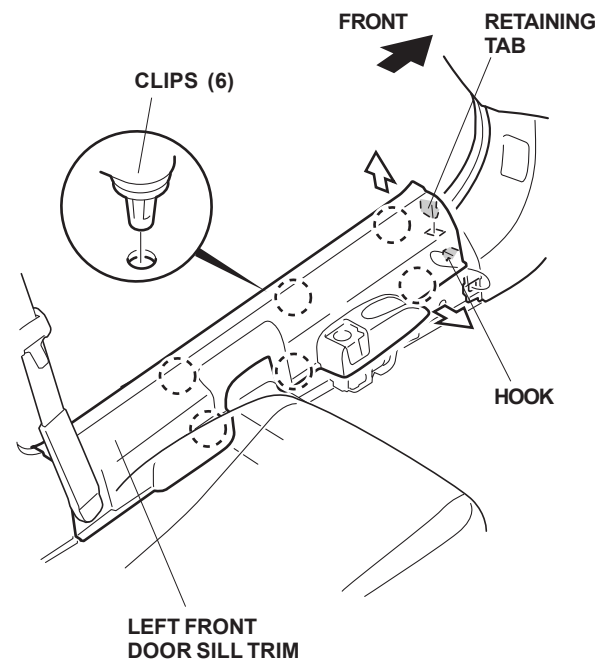

31. Remove the footrest.

- Using a hexagon wrench, remove the lower clip from the stud bolt.
- Using a flat-tip screwdriver, remove the upper clip from the stud bolt.

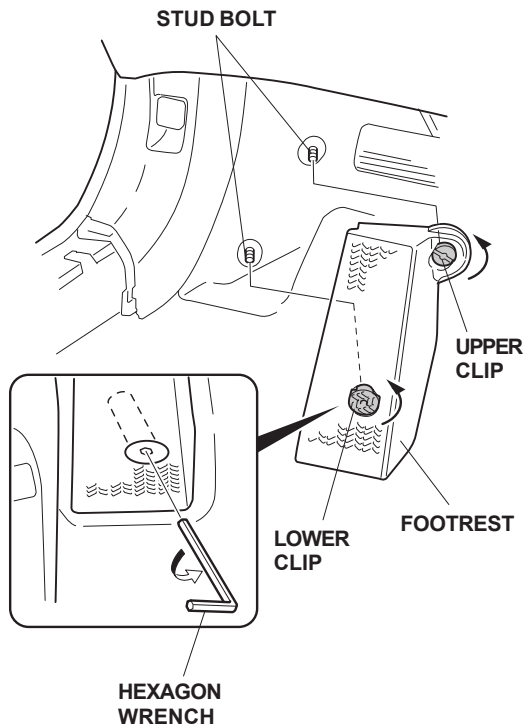

32. Pull away the weatherstrip from left kick panel and remove the left kick panel (two clips).

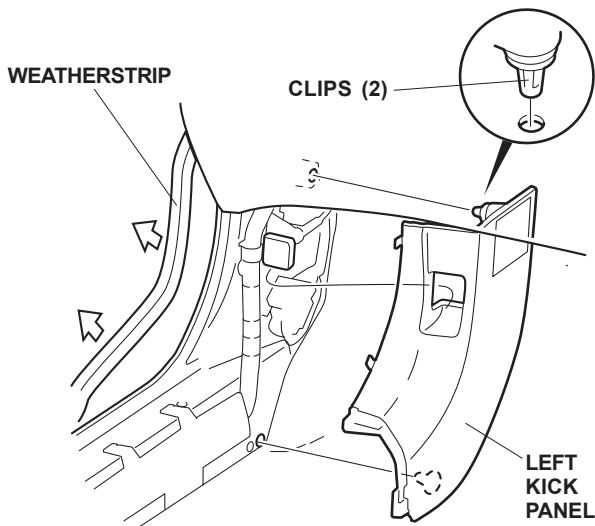

33. If equipped remove the driver's dashboard under cover (turn the lock knob 90° counterclockwise, and release the two clips and pin).

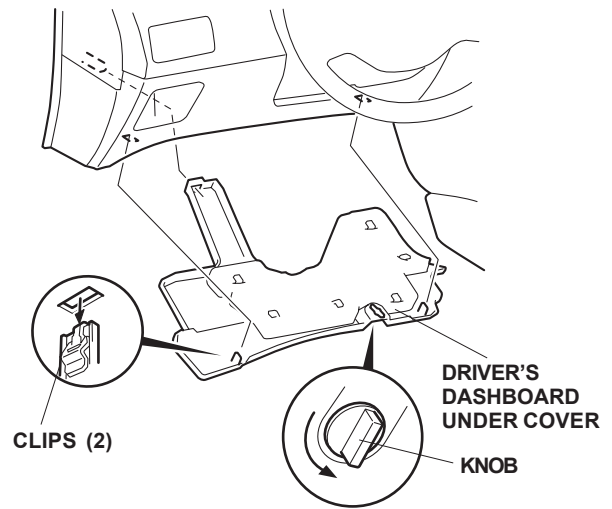

34. Remove the driver's dashboard lower cover (eight clips).

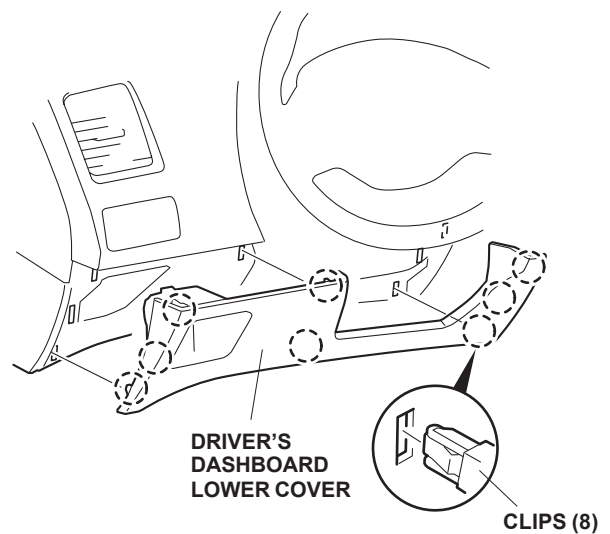

35. Lower the tilt lever, and pull the steering wheel toward you. Insert a flat-tip screwdriver along the guide of the column lower cover, and pry the retaining tab of the column upper cover.

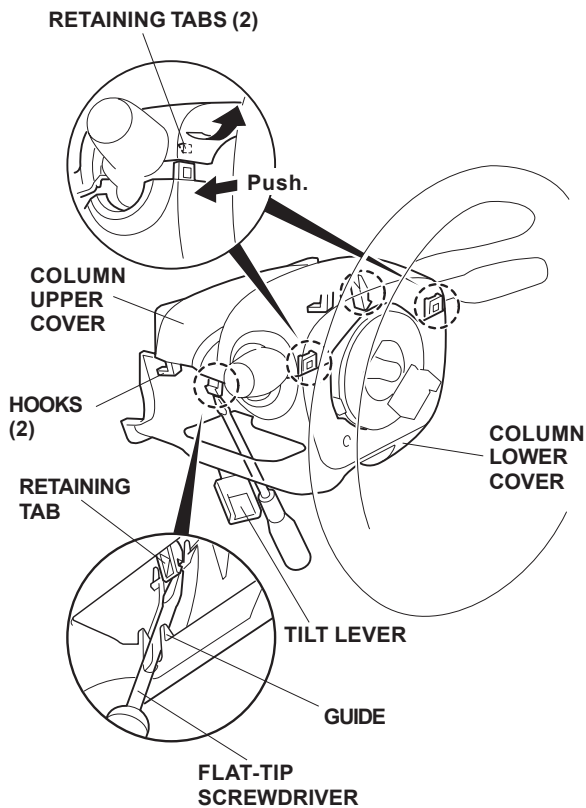

36. Push on the column lower cover in the area to separate the column upper cover from the column lower cover (two retaining tabs). Pull up to remove the column upper cover (two hooks).

37. Remove the column lower cover (two self-tapping screws and one screw).

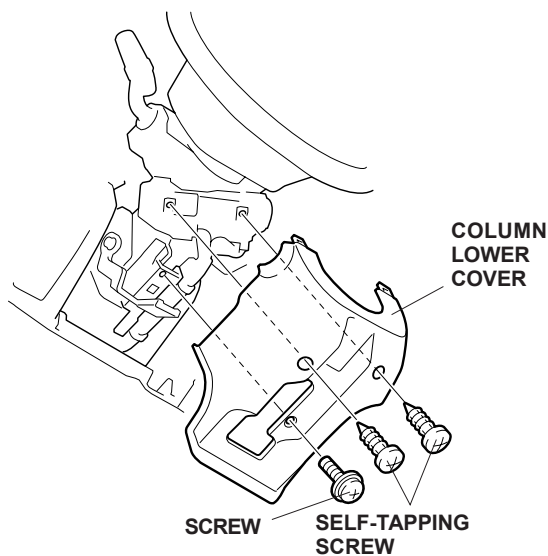

38. Remove the vehicle's green 42-pin connector, white 34-pin connector and the blue 21-pin connector from the fuse box by pushing the retaining tab and raising the lock of the respective connectors. Return the lock on the vehicle white 34-pin connector and remove the cover by sliding it.

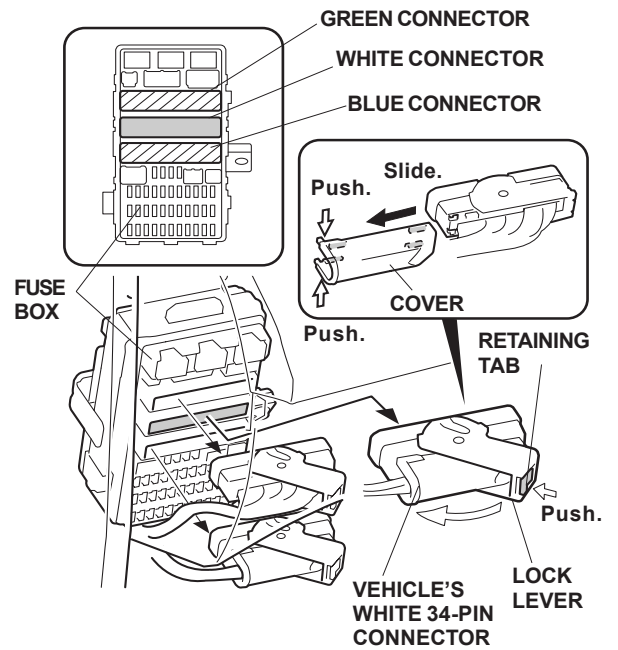

39. Insert the white/red and blue terminals from the switch harness into the vehicle white 34-pin connector.

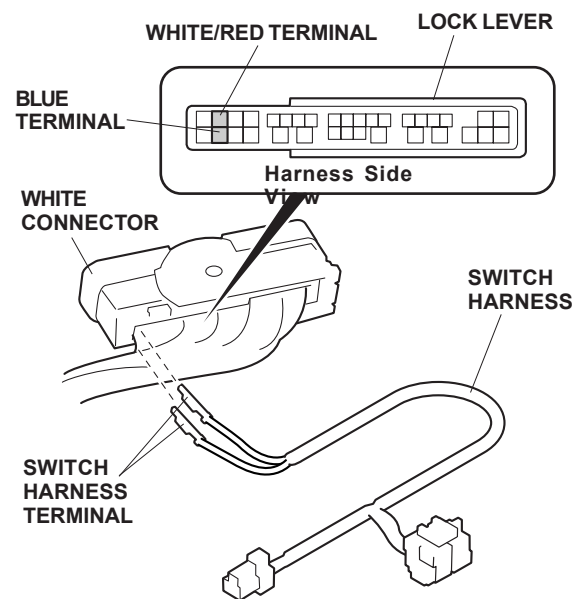

40. Reinstall the vehicle connectors.

41. Route the switch harness above the vehicle knee bolster.

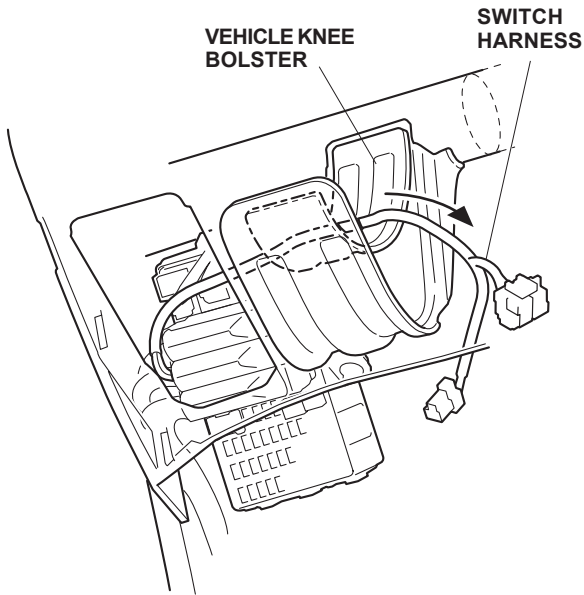

42. Plug the relay into the switch harness relay block, then slide the relay block onto the vehicle bracket stay.

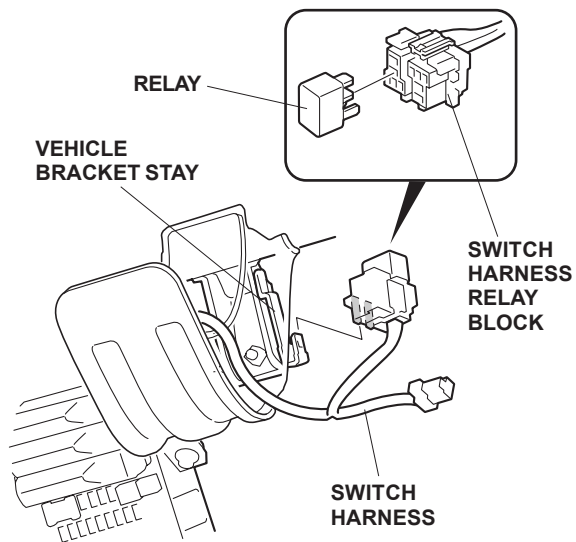

43. Locate the 1-pin connector blue-taped to the vehicle harness. Plug the 1-pin connector into the 1-pin connector of the switch harness.

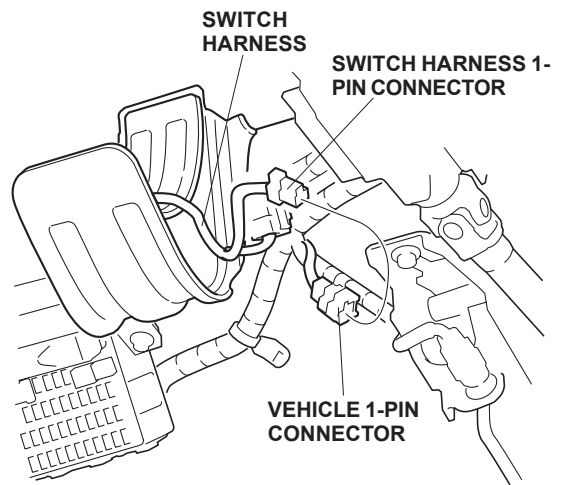

44. Secure the switch harness to the vehicle harness and vehicle knee bolster with three wire ties in the areas shown.

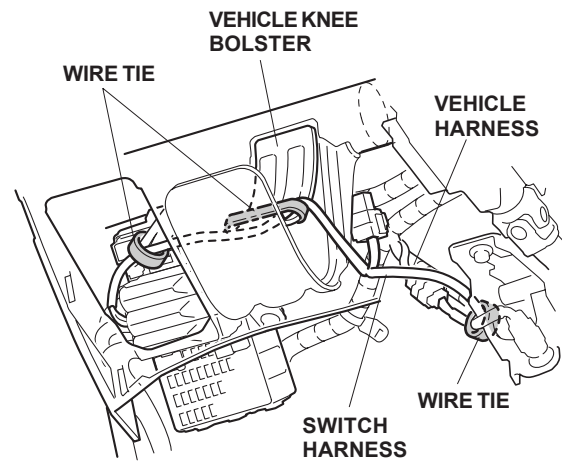

45. Lower the tilt lever and pull the steering wheel toward you.
46. Turn the steering wheel 90° counterclockwise.

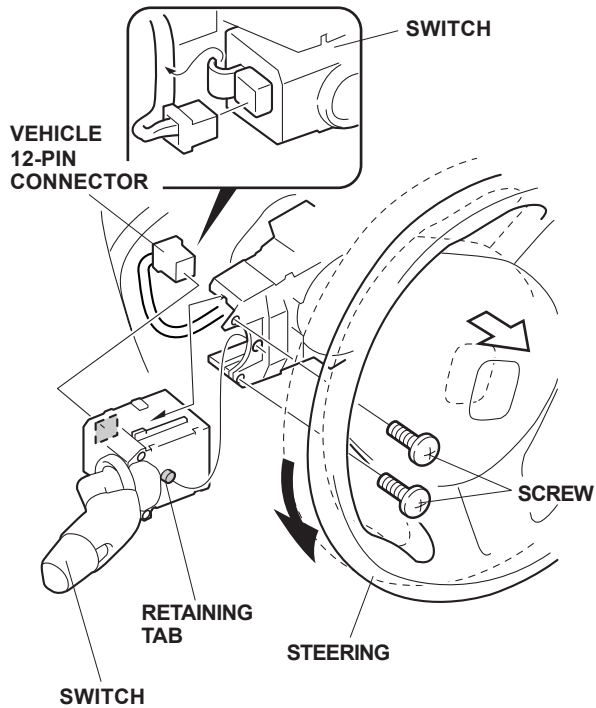

47. Remove the vehicle 12-pin connector from the switch. Remove the two screws from the switch. While pushing the retaining tab, remove the switch.

48. Install the new switch provided where the old switch was removed. Then plug the vehicle 12-pin connector to the new switch. Replace the vehicle harness. Do not install the switch while holding the lever.

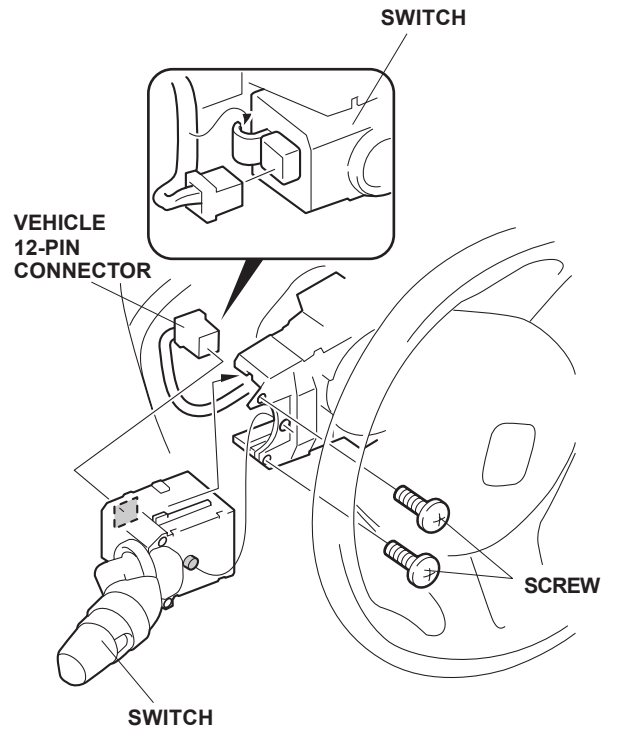

49. Install the 20 A fuse into the fuse box in the location shown.

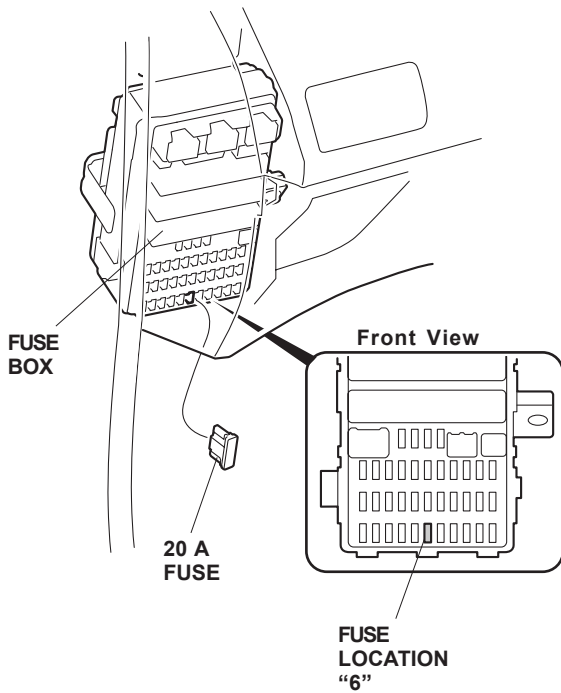

50. Check that all wire harnesses are routed properly and all connectors are plugged in.
51. Reinstall all removed parts. Do not reinstall the outboard bumper bolts at this time.
52. Reconnect the negative cable to the battery.

USE AND CARE

HOW TO OPERATE FOG LIGHTS

NOTE: The fog light lenses can cloud when the outside temperature is cold; this is normal and should go away in warm weather.

- Turn the light switch to the "D" position (headlights on low beam).
- Make the fog light switch on (indicator is on).
- If the fog light don't come on, check the fuse and all the connectors, including the ground cable.

FOG LIGHT AIMING ADJUSTMENT

53. Adjust the fog light:

- Adjust the aim according to local laws and regulations.
- To adjust, turn the aiming adjustment knob in or out until the correct aim is obtained.

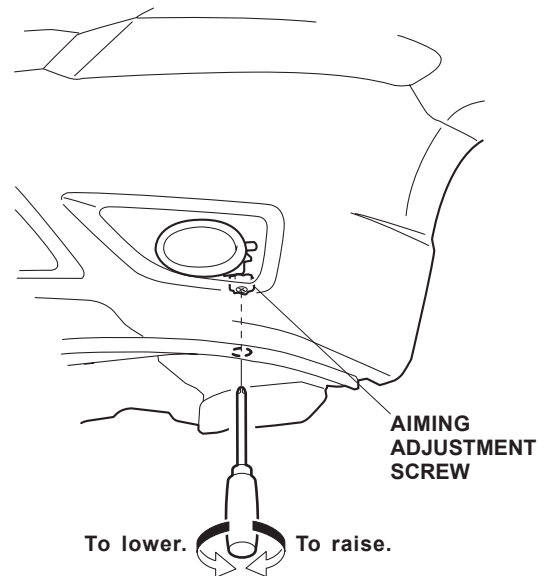

5311251T

54. Reset the clock, and reset the radio station presets.

BULB REPLACEMENT

1. Remove the six clips and bumper bolt from the bottom of the front bumper, then pull down the under cover and inner fender.

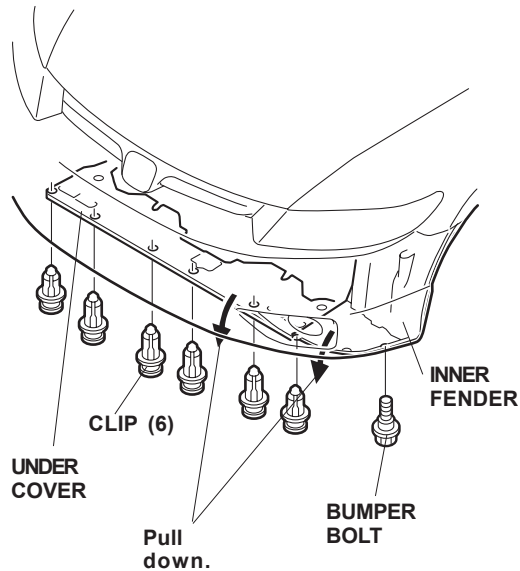

2. Disconnect the fog light connector by accessing it from the center side of the vehicle.
3. Remove the bulb.

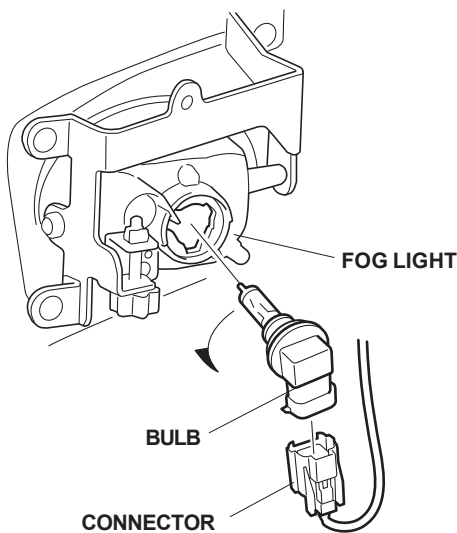

4. Install the new bulb and socket to the fog light.
 - Use only a genuine Honda halogen light bulb of specified wattage.
Rating: 12V 55W H11 Halogen Light Bulb P/N 33165-S5A-003
 - Do not touch the bulb. Oily or greasy substances on the bulb can shorten its service life due to the heat produced when the bulb is turned on. If the bulb is accidentally touched, wipe it clean with a soft cloth that has been dampened with a denatured alcohol or a mild detergent solution.
 - Align the tab on the fog light with the cutout in the bulb when installing the new bulb. If not aligned, the fog light may annoy oncoming drivers.

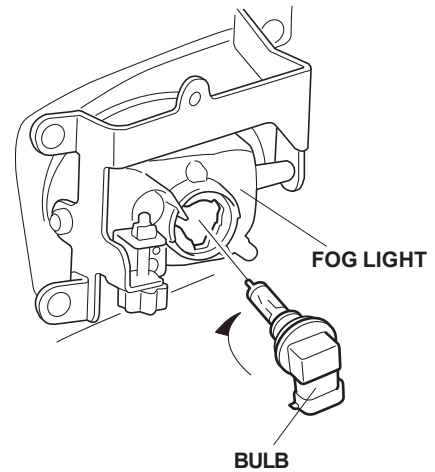

5. Reinstall the removed parts in the reverse order of removal.
 - Check that the wire harnesses are not pinched.
 - Be sure to tighten the self-tapping screw and bolts securely.
6. Check the operation of the fog light; adjust the aiming if necessary.

CIRCUIT DIAGRAM

<Si model>

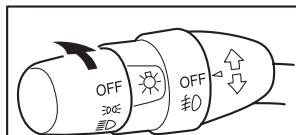
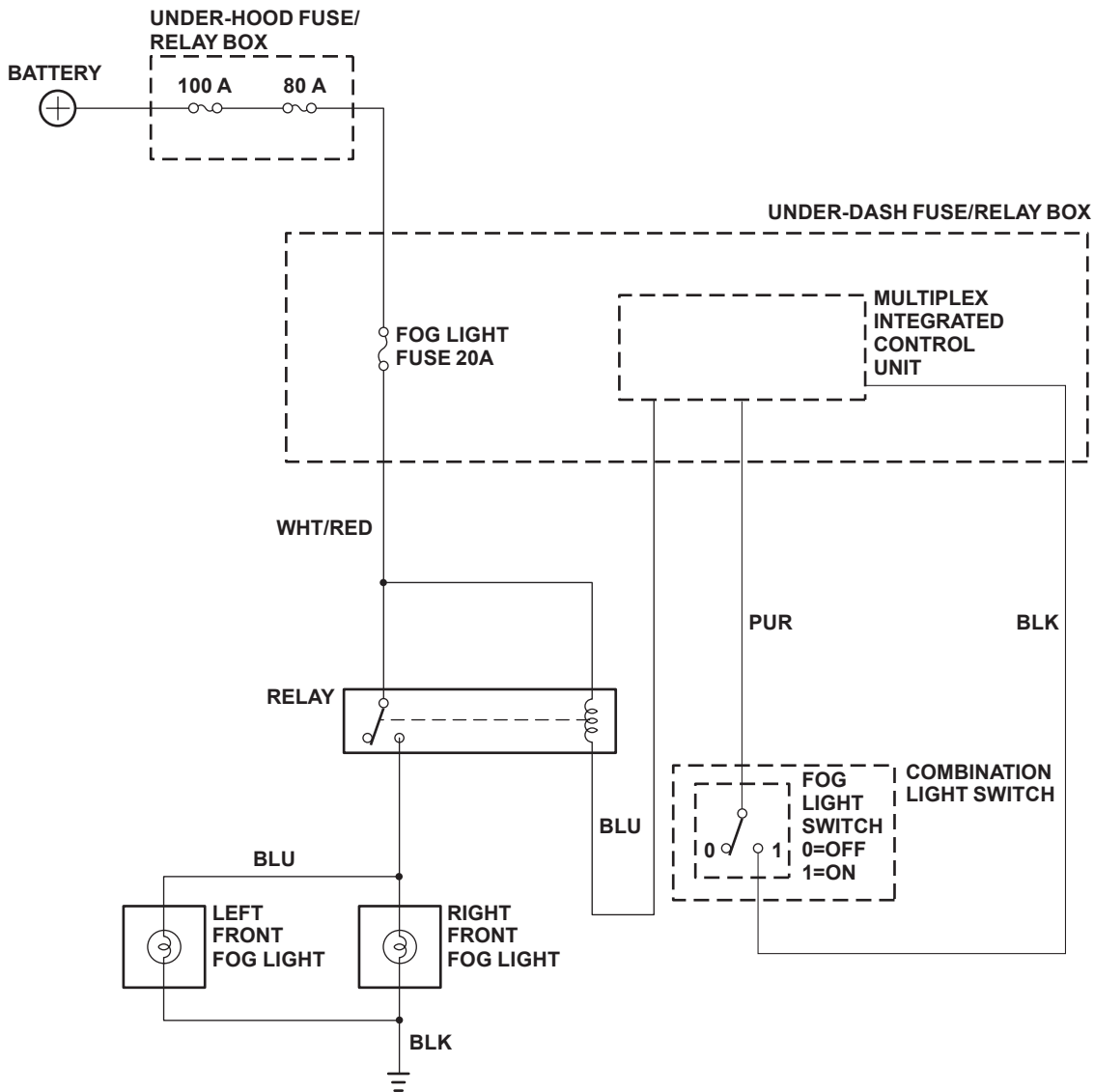

HEADLIGHT SWITCH					
OFF	Low	Hi		ON	-
		Low	Hi		
OFF	-	-	-	-	-
ON	-	-	ON	-	-

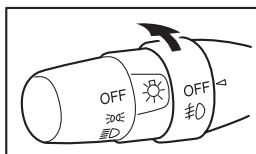

FOG LIGHT SWITCH					
OFF	ON				
		OFF	-	-	-
ON	-	-	ON	-	-

BLK	BLACK	BRN	BROWN
YEL	YELLOW	ORN	ORANGE
BLU	BLUE	PUR	PURPLE
GRN	GREEN	PNK	PINK
RED	RED	GRY	GRAY
WHT	WHITE	LT GRN	LIGHT GREEN
LT BLU	LIGHT BLUE		