



INSTALLATION INSTRUCTIONS

Accessory

RUNNING BOARDS
P/N 08L33-SHJ-100

Application

2010 ODYSSEY

Publications No.

All 41846

Issue Date

JUNE 2009

PARTS LIST

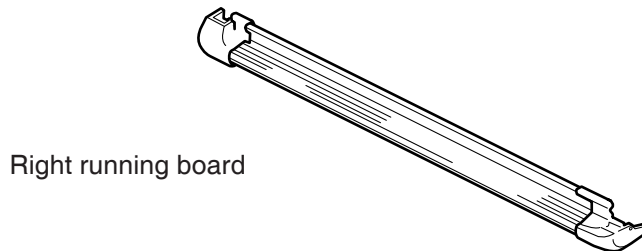

Right running board

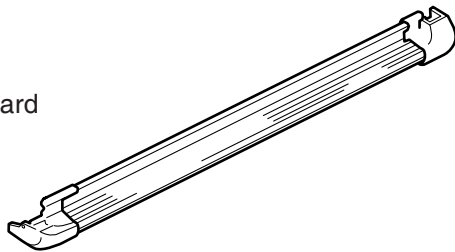

Left running board

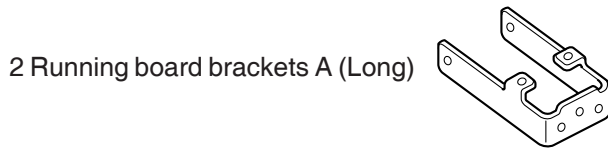

2 Running board brackets A (Long)

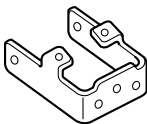

2 Running board brackets B (Short)

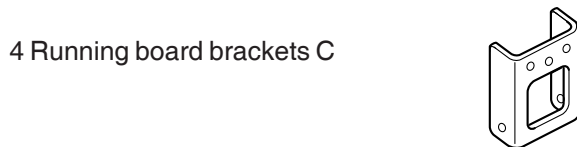

4 Running board brackets C



32 Flange bolts

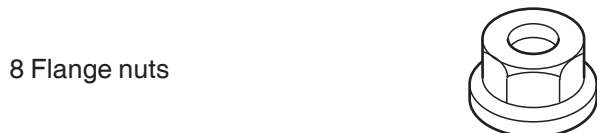

8 Flange nuts

12 Door panel seals



12 Seals



TOOLS AND SUPPLIES REQUIRED

Torque wrench

Phillips screwdriver

Blanket

Drill

3 mm and 6 mm Drill bits

File

Eye protection (face shield, safety goggles, etc.)

Pushpin

Shop towel

Isopropyl alcohol

13 mm Socket

13 mm Wrench

INSTALLATION

NOTE:

- Thoroughly clean the bottom of the body from the end of the front wheel up to the front of the rear wheel.
- These installation instructions show the left running board being installed; the same procedure applies to installing the right running board.
- To prevent damage to the running board, place a blanket under the running board during installation.
- The running boards cannot be installed on a vehicle equipped with splash guards.

1. Turn the steering wheel fully counterclockwise.

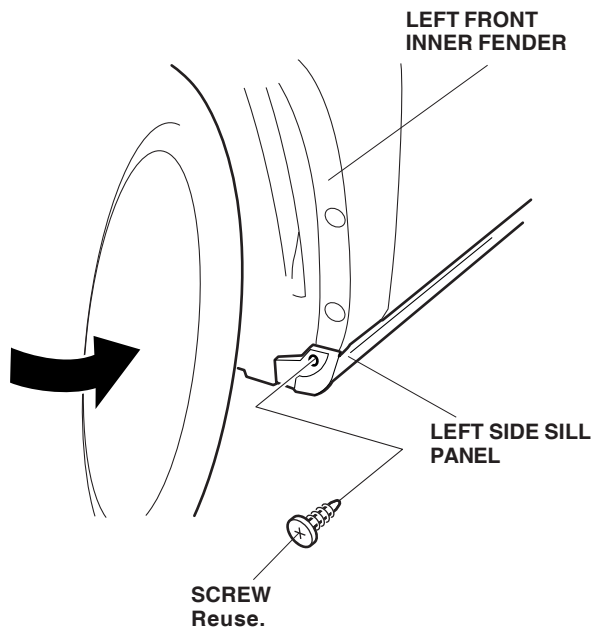

2. Remove a screw from the left front inner fender.
3. Remove the left side sill panel by sliding it toward the front of the vehicle to release the 12 clips from the sill panel.
4. Remove 12 clips from the vehicle panel by turning them 45°.

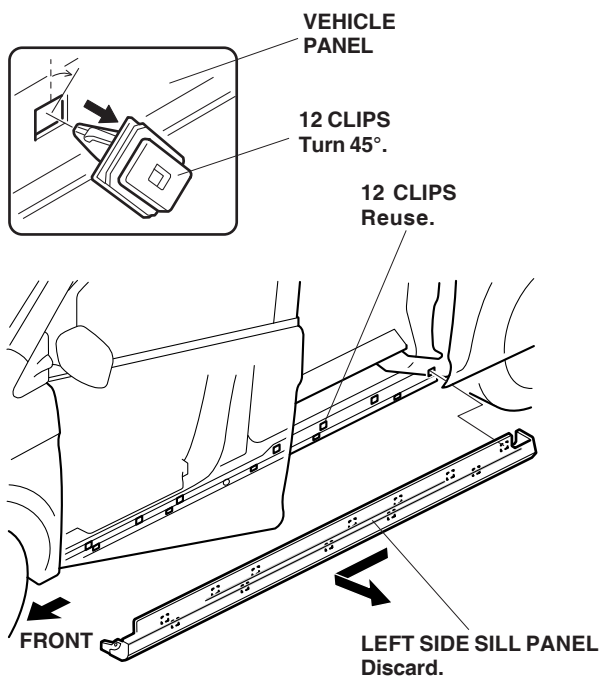

Installing the Running Board

5. Using isopropyl alcohol on a shop towel, thoroughly clean the area where the door panel seal will be attached. Attach the door panel seals on the lower five clip holes and one upper clip hole.

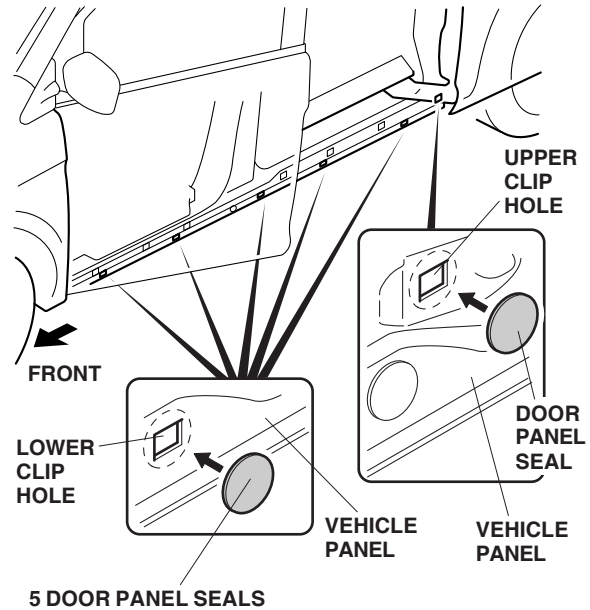

6. Temporarily secure the running board bracket A (long) and B (short) to the vehicle with four flange bolts as shown.

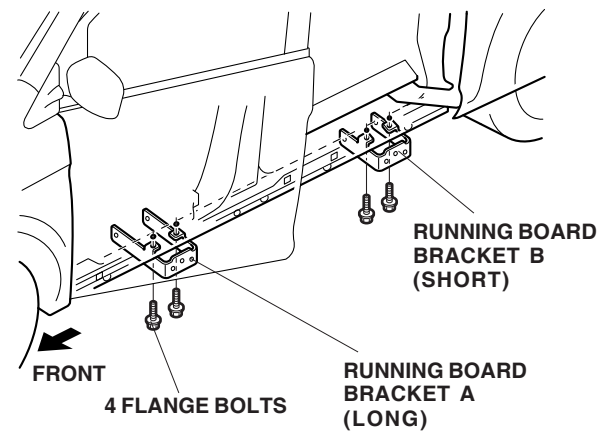

- Temporarily secure the running board brackets C to the running board bracket A (long) and B (short) with four flange bolts and four flange nuts as shown.

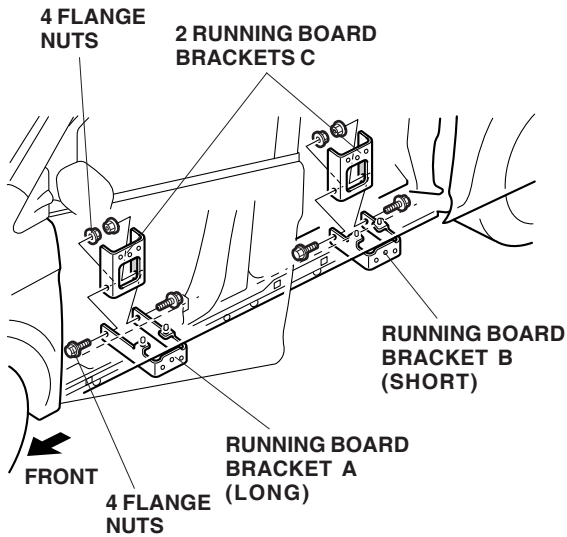

- Temporarily secure the running board bracket C to the vehicle with two flange bolts at the indicated holes as shown.

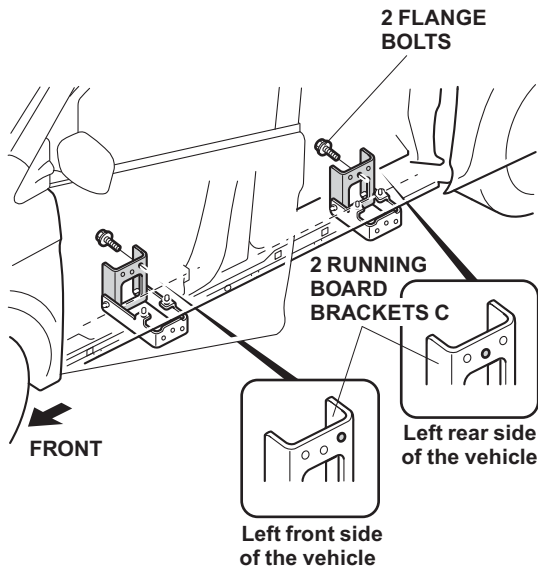

- Pierce the center of the scribe mark on the left running board front end cap with a pushpin as shown.

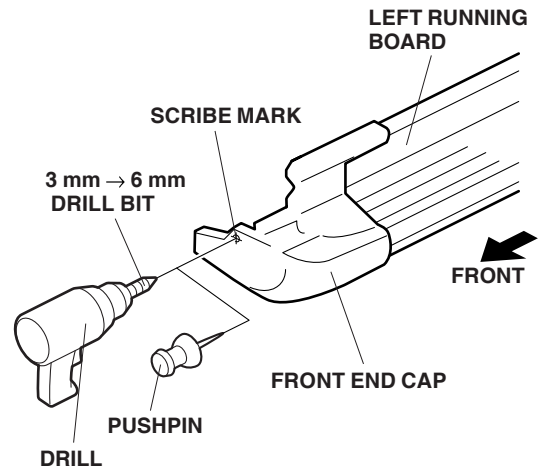

- While wearing eye protection, drill a hole with a 3 mm drill bit at the pierced point on the left running board, and widen the hole with a 6 mm drill bit. Remove any burrs at the edge of the hole you drilled using a file.
- Replace the seal on the clips (reused) with a new seal. Slide six clips into the left running board as shown.

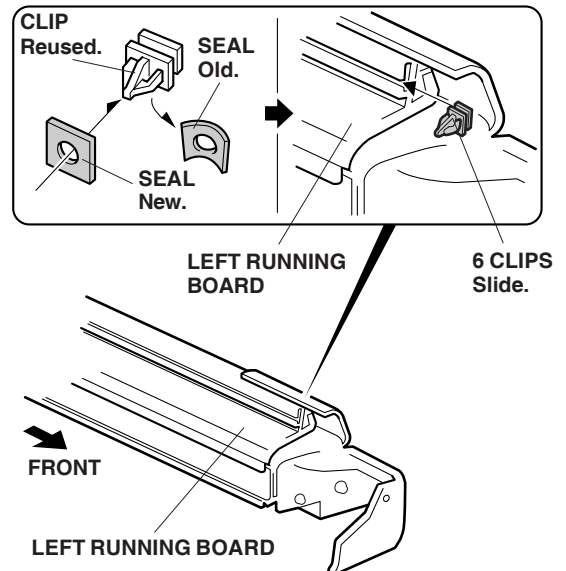

12. Hold the running board up and fit all the clips into the holes in the body, then push on the top of the running board until the clips snap into place.

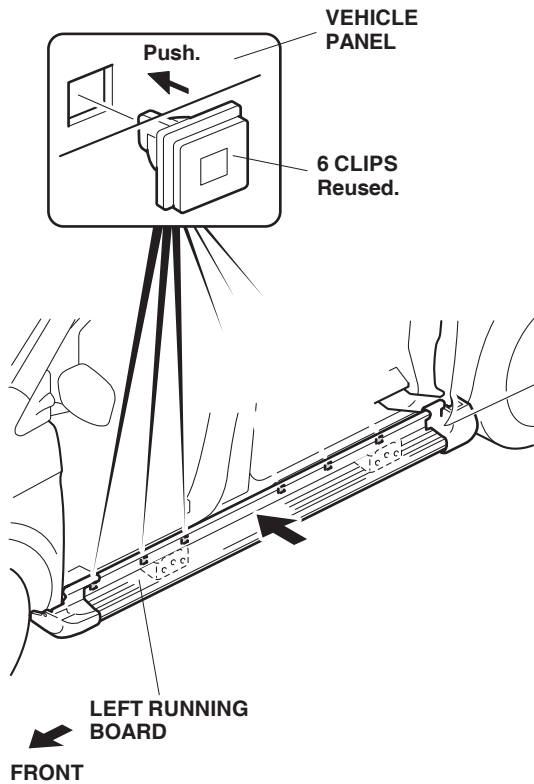

13. Hook the left running board to the ledge on the running board bracket A (long) and B (short) as shown. Install the left running board with six flange bolts. Torque the flange bolts to 27 N·m (20 lb-ft).

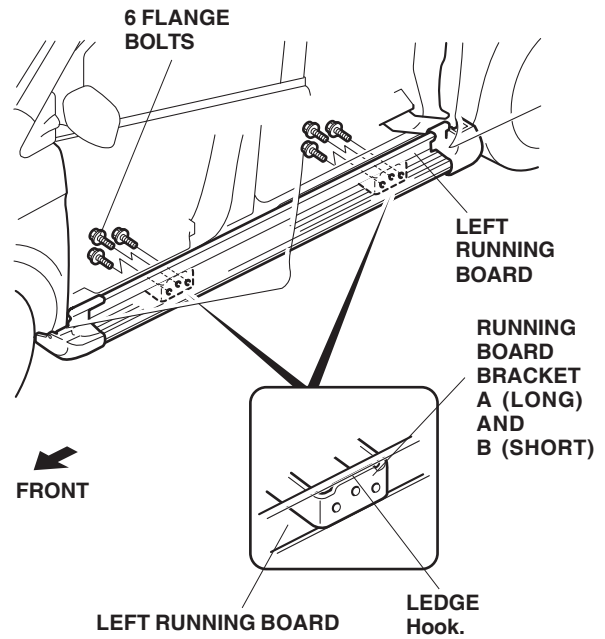

14. Tighten the 10 flange bolts and four flange nuts temporarily secured in steps 6 thru 8. Torque the flange bolts to 27 N·m (20 lb-ft).

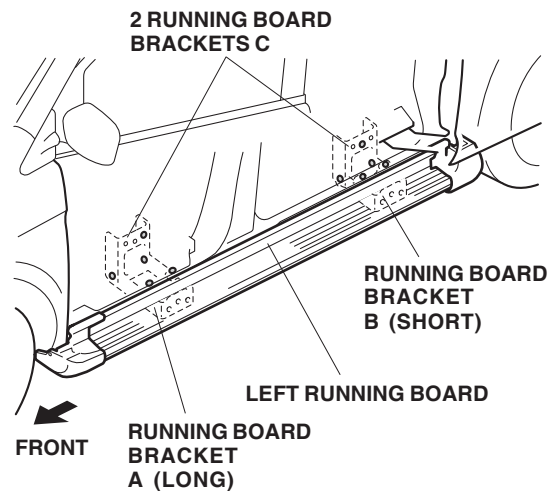

15. Secure the left running board with the screw you removed in step 2 to the left front inner fender as shown.

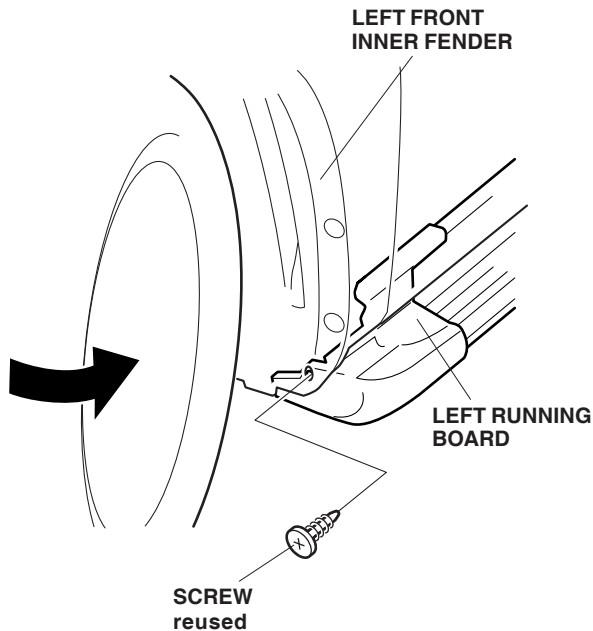

16. Repeat steps 1 thru 15 on the right side of the vehicle.

Removing the Running Board (if necessary)

17. Turn the steering wheel fully counterclockwise.

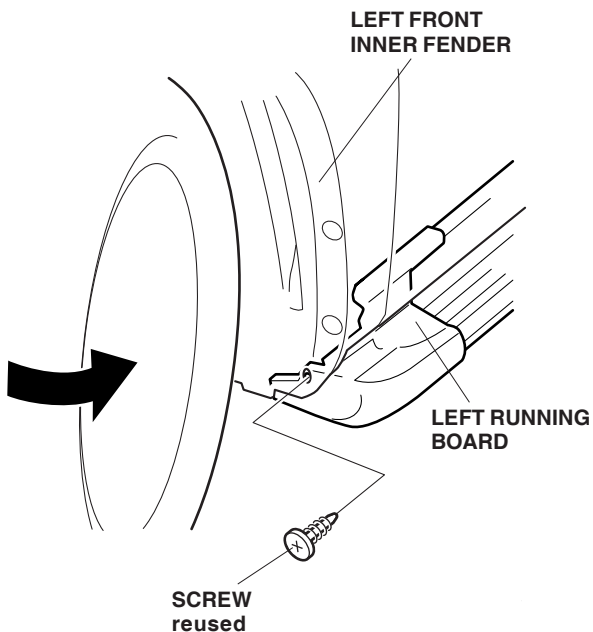

18. Remove the screw securing the left running board.

19. Remove six flange bolts from the running board bracket A (long).

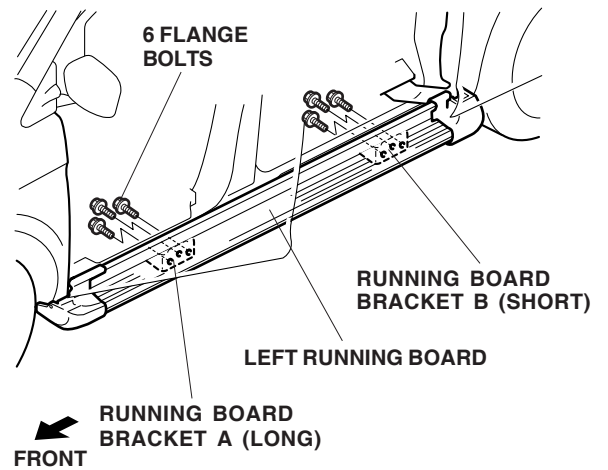

20. Loosen the remaining eight flange bolts securing the running board bracket A (long) and B (short).

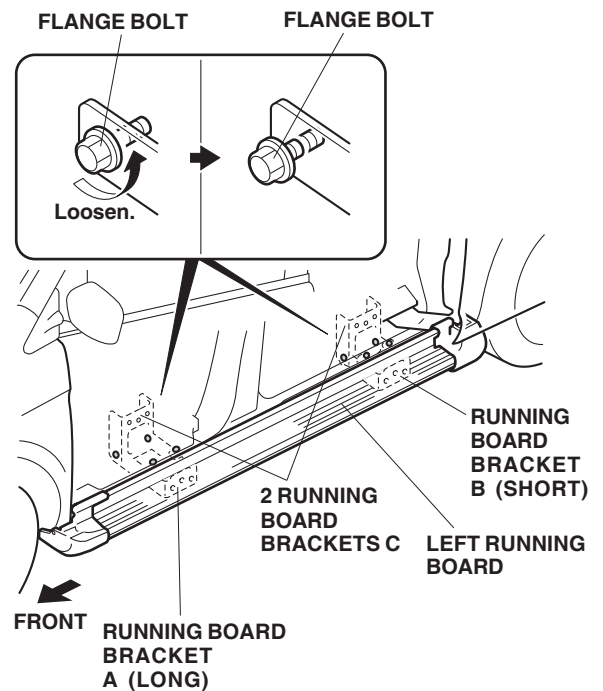

21. Disengage two bolts and remove the rear end cap of the running board.

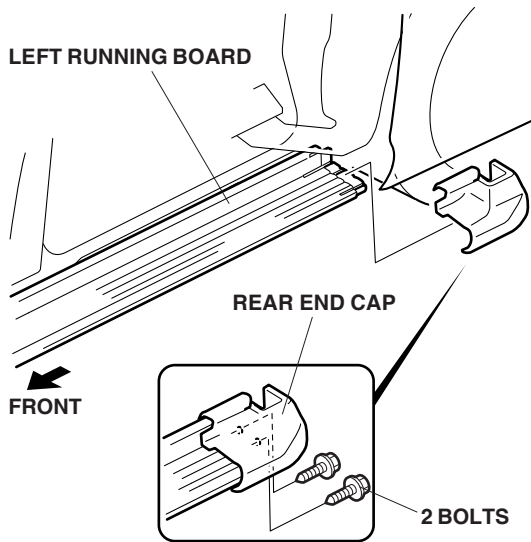

22. Peel off the upper rubber part and pull to remove the running board from the retainer.

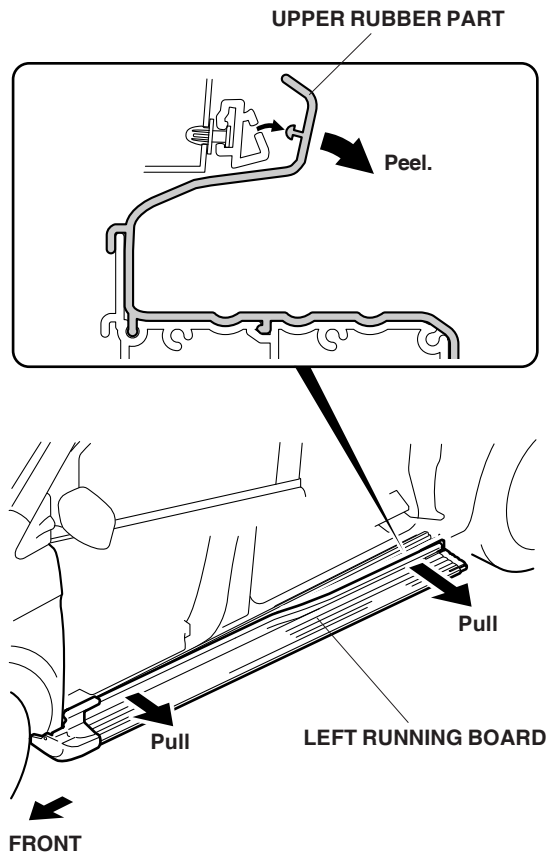

23. Slide the retainer off from the clips on the vehicle panel.

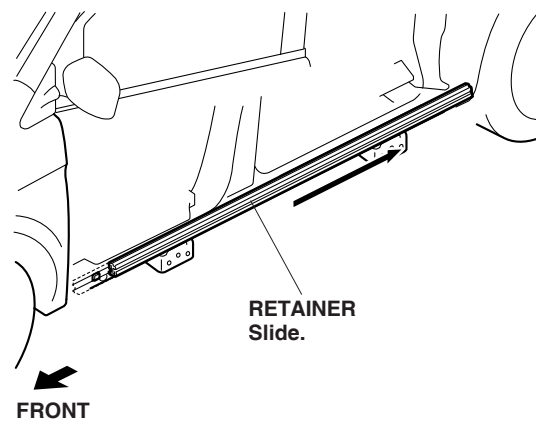

24. Remove six clips from the vehicle panel by turning them 45°.

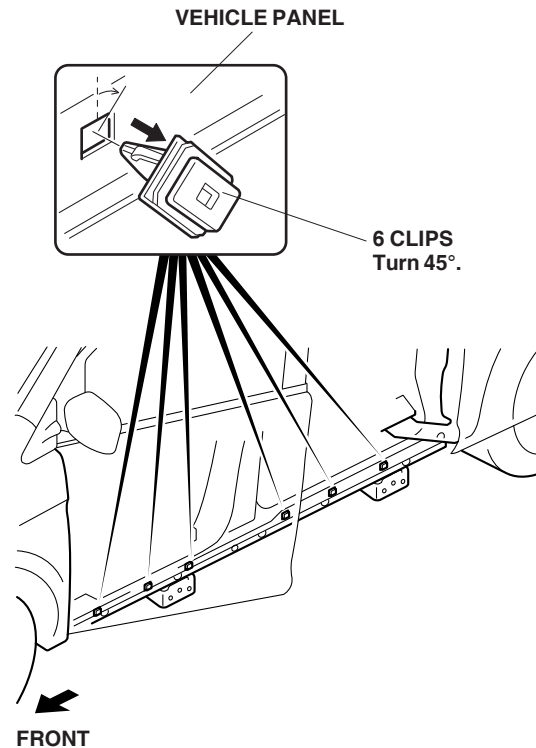

25. Remove the 10 flange bolts securing the running board brackets A (long), B (short), and C from the vehicle. Remove the brackets.

26. Repeat steps 17 thru 25 on the right side of the vehicle.