



INSTALLATION INSTRUCTIONS

Accessory
TRAILER HITCH

Application
2009 ODYSSEY

Publications No.
All 40237
Issue Date
AUG 2008

NOTE: A required heavy-duty power steering cooler, ATF cooler and air duct are required before towing. Have the recommended parts (sold separately) available when installing the trailer hitch kit.

PARTS LIST

Trailer Hitch (sold separately)
P/N 08L92-SHJ-100

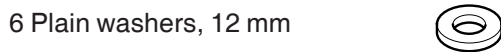
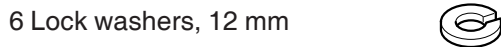
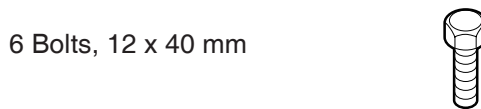
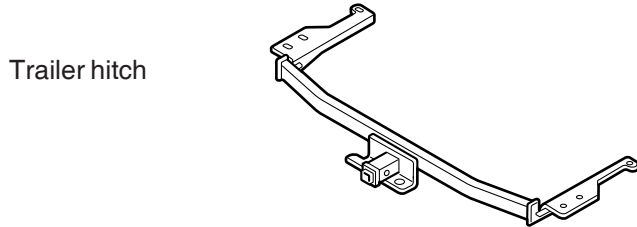

Trailer Hitch Harness (sold separately)
P/N 08L91-SHJ-100

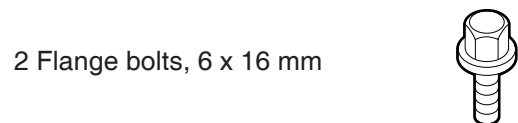
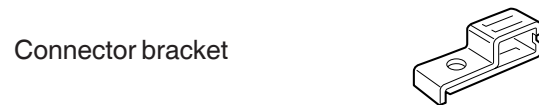
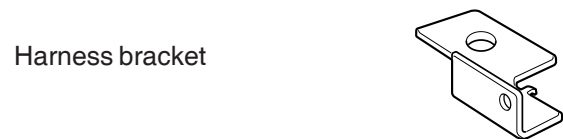
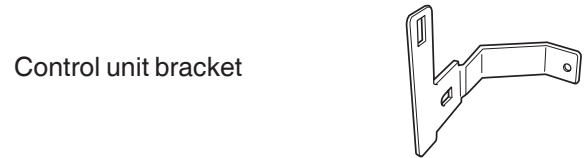
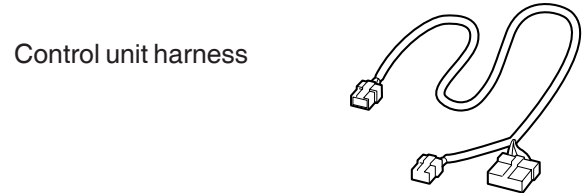
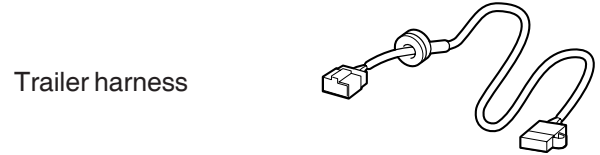

Wire ties with clip

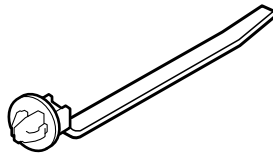

2 Cable clips

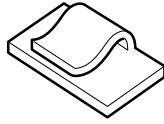

Connector clip



Fuse, 7.5 A

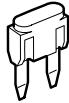

Fuse label

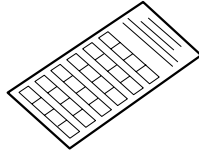

Owner's manual

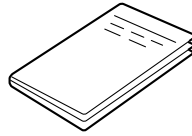

Heavy-Duty P/S Cooler Kit (sold separately)
P/N 53765-SHJ-325

Heavy-duty P/S cooler

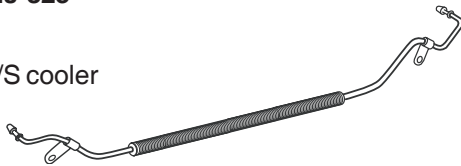

Washer-bolt, 8 x 12 mm



Washer-bolt, 6 x 12 mm



ATF Cooler Kit (sold separately)
P/N 06255-RGL-305

ATF Cooler

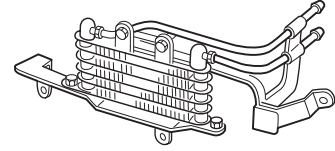

Rubber hose (370 mm)



Rubber hose (320 mm)



Rubber hose (220 mm)



2 Washer-bolts, 6 x 12 mm



Nut, 6 mm



6 Hose clamps



ATF hose spacer



2 Hose clips



Mirror "hang tag"



Air Duct (sold separately)
P/N 71105-SHJ-A01

Air duct

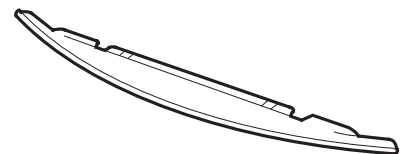

4 Clips



TOOLS AND SUPPLIES REQUIRED

- Phillips screwdriver
 - Flat-tip screwdriver
 - Ratchet
 - 5 mm, 6 mm, 10 mm, 12 mm, and 19 mm Sockets
 - Utility knife
 - Tape measure
 - Clip remover
 - Diagonal cutters
 - Sandpaper
 - Torque wrench
 - Drill
 - Blanket
 - Eye protection (safety goggles, face shield, etc.)
 - 4 Pushpins
 - Isopropyl alcohol
 - Shop towel
 - Piece of stiff wire
- Available through the Honda Tool and Equipment Program at 888-424-6857:*
- Hole saw 13/16 in. (20 mm) P/N: LHS26D
 - Arbor P/N: LHS1C

Illustration of the Trailer Hitch Installed on the Vehicle

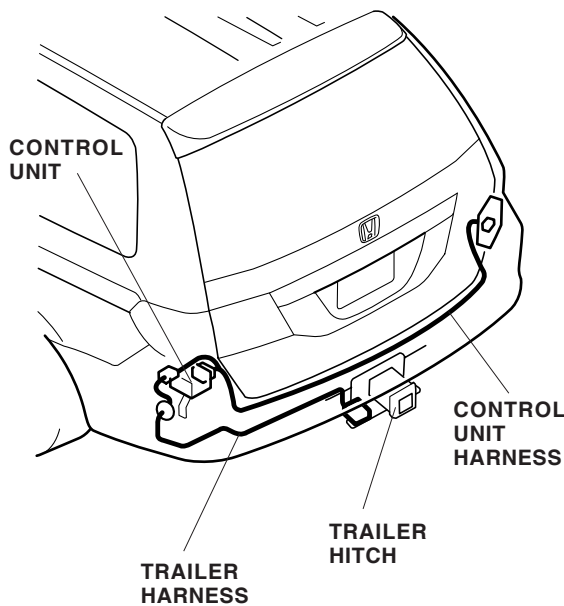

INSTALLATION

Customer Information: The information in this installation instruction is intended for use only by skilled technicians who have the proper tools, equipment, and training to correctly and safely add equipment to your vehicle. These procedures should not be attempted by “do-it-yourselfers.”

NOTE:

- Be careful not to damage the rear bumper or other finished surfaces of the body.
 - Let the P/S fluid, the ATF, and the surrounding parts cool down before you install the coolers.
1. Make sure you have the anti-theft code for the radio, then write down the audio presets.
 2. Disconnect the negative cable from the battery.
 3. Remove the rear bumper.
 - If equipped, remove the two screws (one on each side) that secure the inner fender.
 - Remove the four self-tapping screws (two on each side) at the fenderwell.
 - Using a clip remover, pry out and remove the three clips along the bottom of the bumper.
 - Using a flat-tip screwdriver, pry out and remove the bumper bolt covers, then remove the four bumper bolts.
 - With the help of an assistant, release the bumper from the fenderwell, and slide the bumper away from the vehicle.
 - If equipped, unplug the backup sensor connectors.
 - Set the bumper on a blanket.

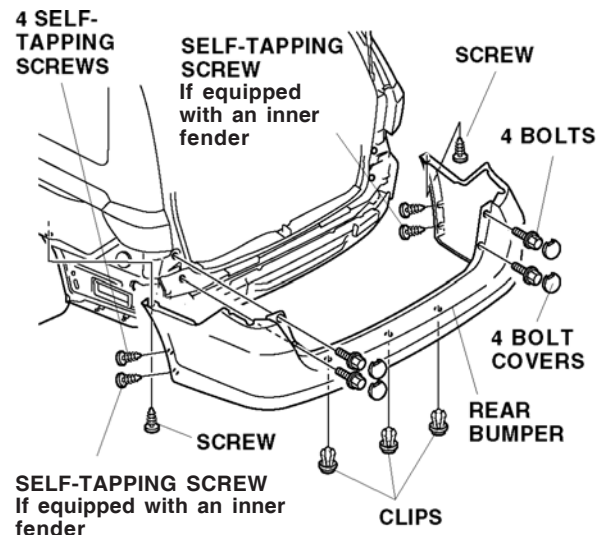

- On the inside of the rear bumper, place the template on the bumper with the hole in the template over the center clip hole.

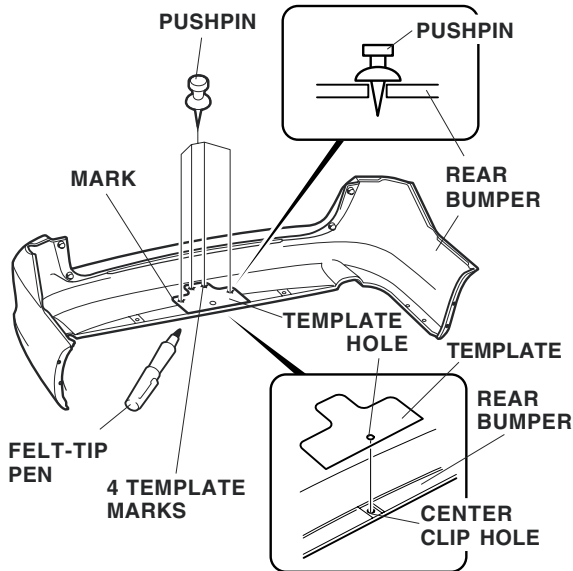

- Using a felt-tip pen, mark the bumper around the outside of the template. Using a pushpin, pierce a hole through the bumper at each of the four marked positions on the template. Remove the template.
- Turn the bumper over. While wearing eye protection, drill a 20 mm hole through the bumper at the four marked locations.

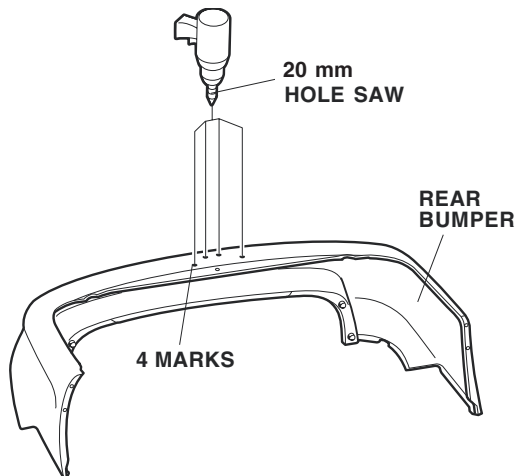

- Using a utility knife, cut along the marked area, and remove the center section of the bumper. Using a file, remove any burrs from the bumper.

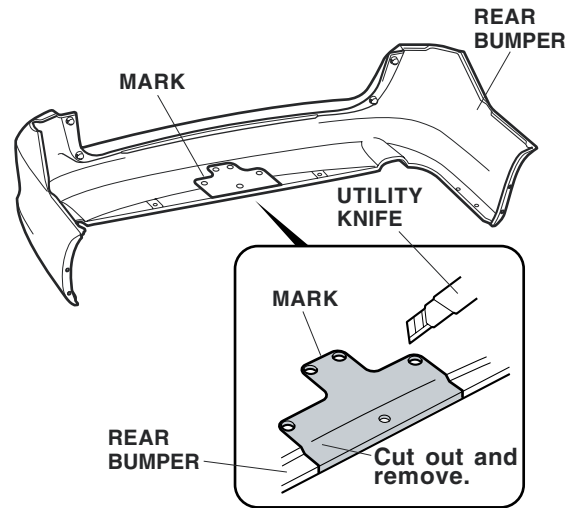

- Install the trailer hitch to the rear frame, using the six 12 x 40 mm bolts, lock washers, and plain washers, tighten the right side bolts first.

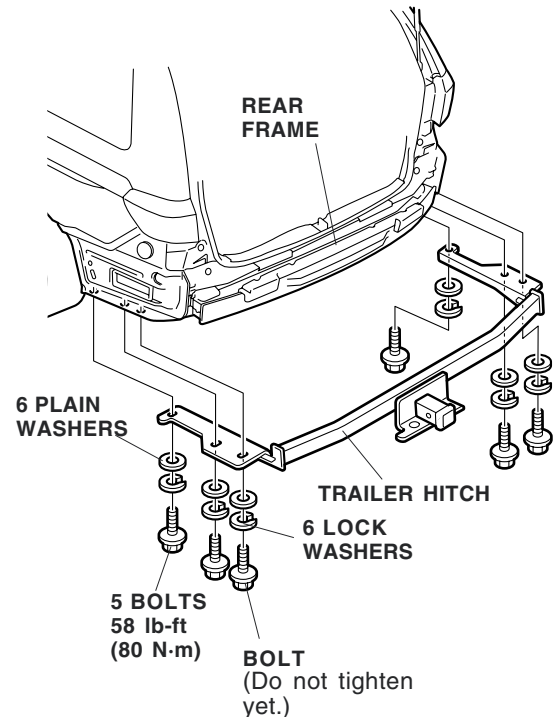

- Torque the five trailer hitch bolts to 58 lb-ft (80 N·m).

Installing the Trailer Hitch Harness

10. Pull out the weatherstrip at the rear trim panel. Remove the rear trim panel (two screws, and lift to release the ten clips).

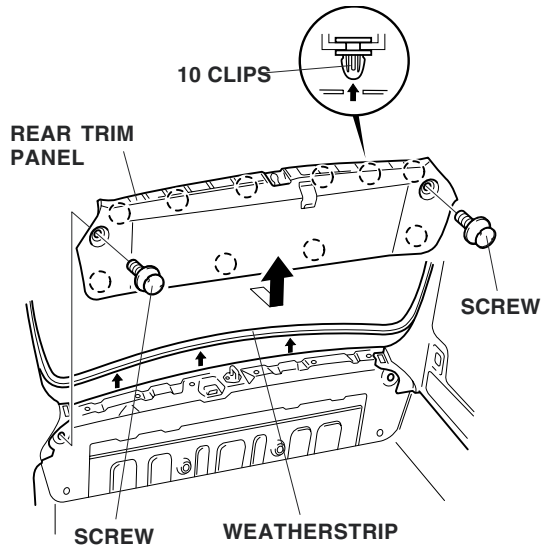

11. Remove the jack cover (two tabs).

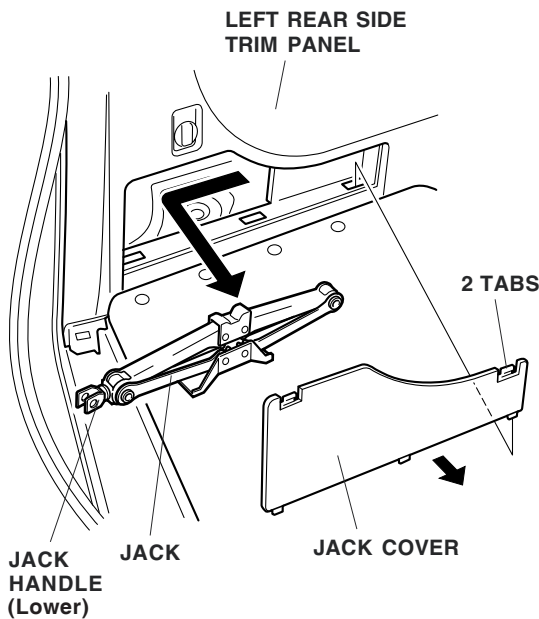

12. Lower the jack handle, then remove the jack.

13. Locate and remove the rubber grommet from the left rear bumper area.

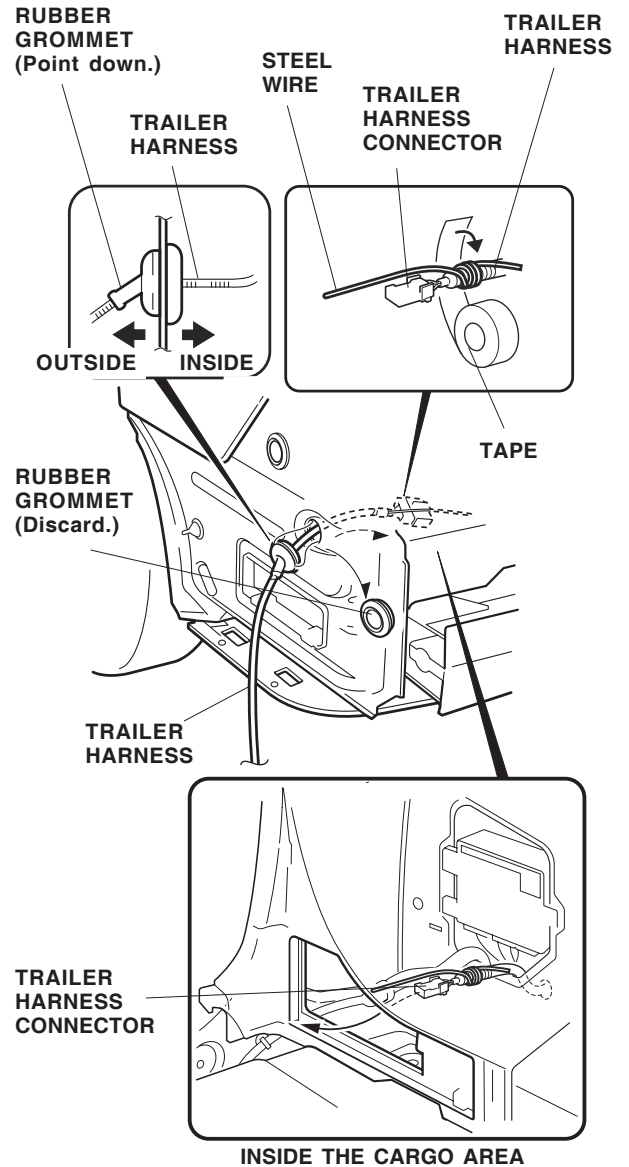

14. Tape the trailer harness connector to a piece of steel wire. Route the trailer harness connector in the cargo area, and seat the rubber grommet into the body panel with the rubber grommet pointing down.

15. Route the trailer harness along the body panel. Using isopropyl on a clean towel, clean the body panel where the cable clips will attach. Attach the cable clips to the body panel, and secure the harness at the green tape using two wire ties attached to the cable clips.

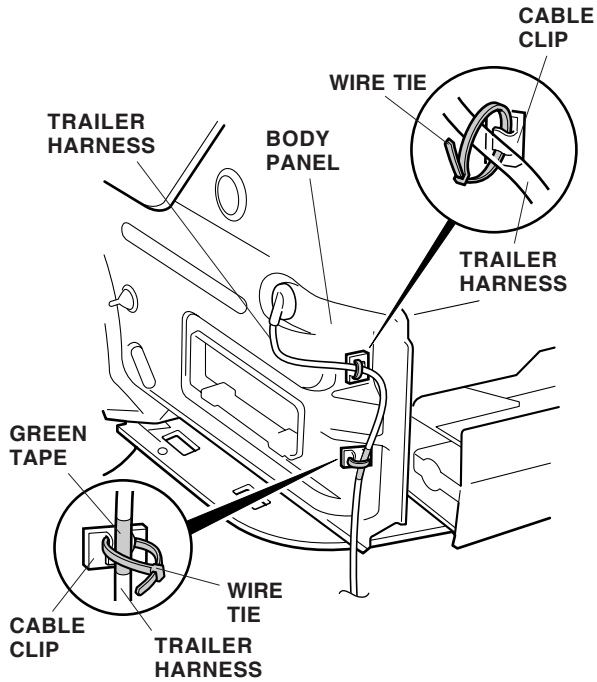

16. Under the left side of the vehicle, remove the rear trailer hitch bolt. Reinstall the trailer hitch bolt with the harness bracket attached. Torque the trailer hitch bolt to 58 lb-ft (80 N·m).

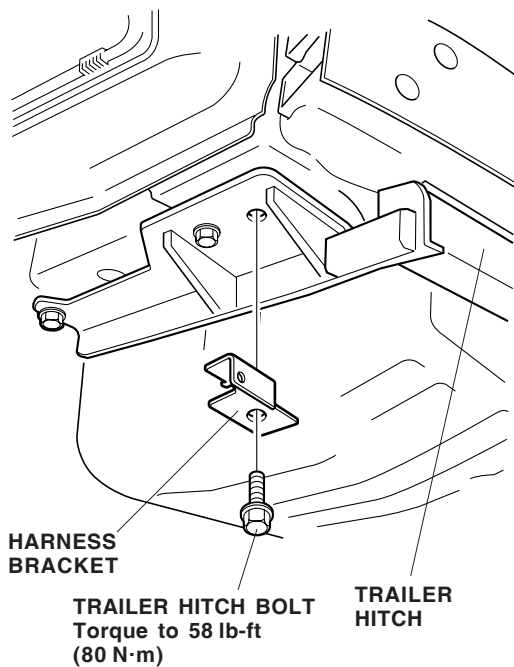

17. Attach one wire tie with clip to the trailer harness at the green tape, then insert the clip into the hole in the harness bracket.

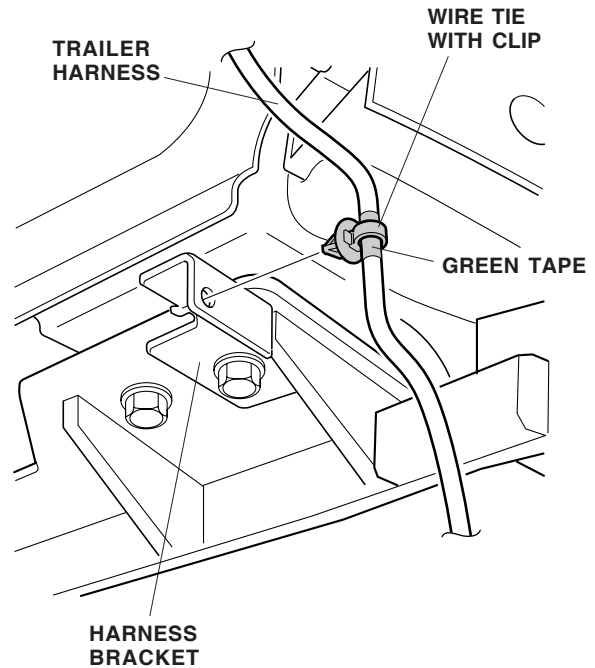

18. Secure the trailer harness to the trailer hitch with four wire ties.

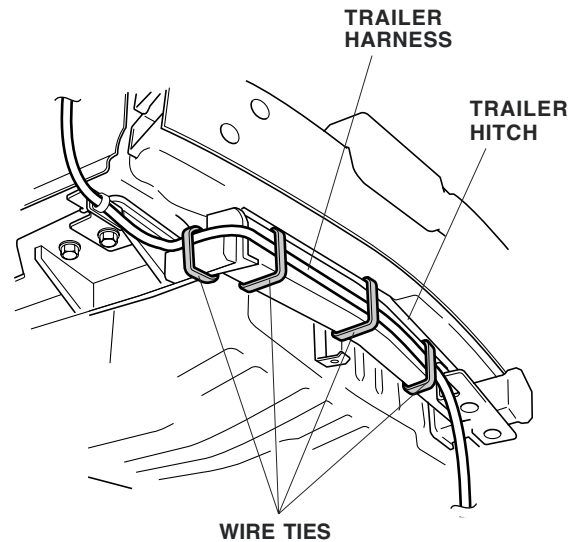

19. Insert the trailer harness 4-pin connector into the connector bracket, then attach the connector bracket to the trailer hitch with the 6 x 16 mm bolt and flange nut.

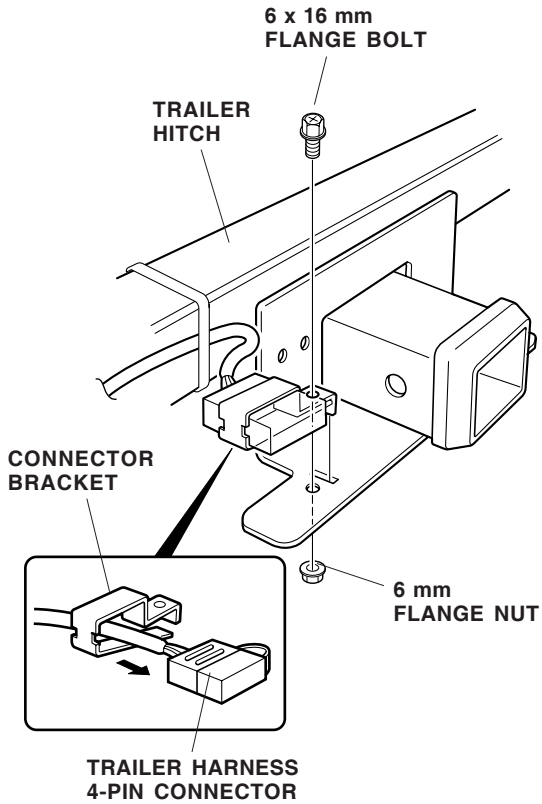

20. Secure the trailer harness to the trailer hitch with two wire ties.

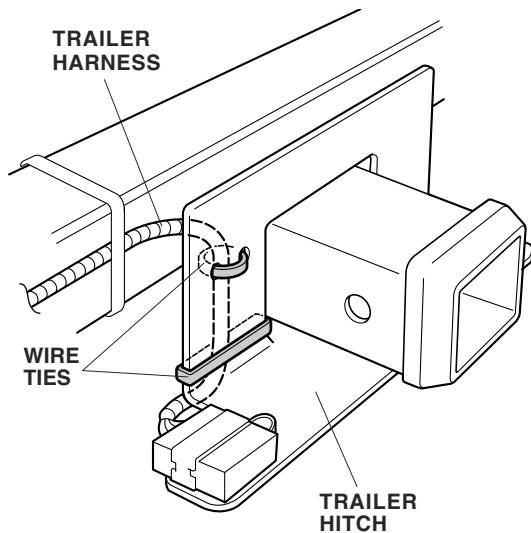

Installing the Control Unit

21. Attach the control unit to the control unit bracket.

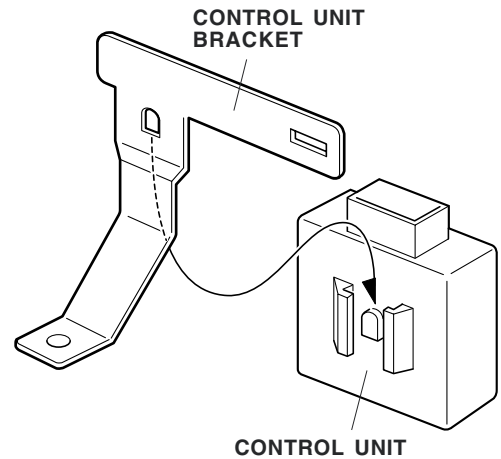

22. Inside the left rear cargo area, insert the control unit bracket through the square hole in the vehicle panel, and secure the control unit assembly with one 6 x 16 mm flange bolt.

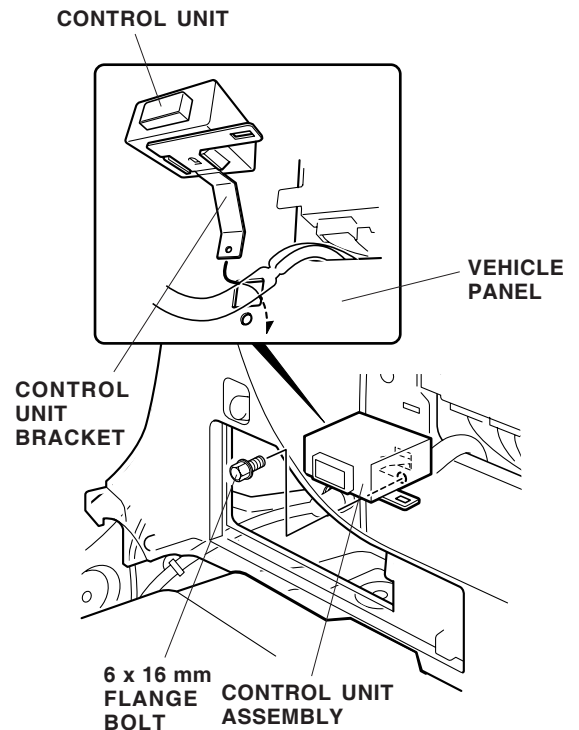

23. Slide the connector clip into the slot on the trailer harness 4-pin connector, then attach the trailer harness 4-pin connector to the control unit bracket.

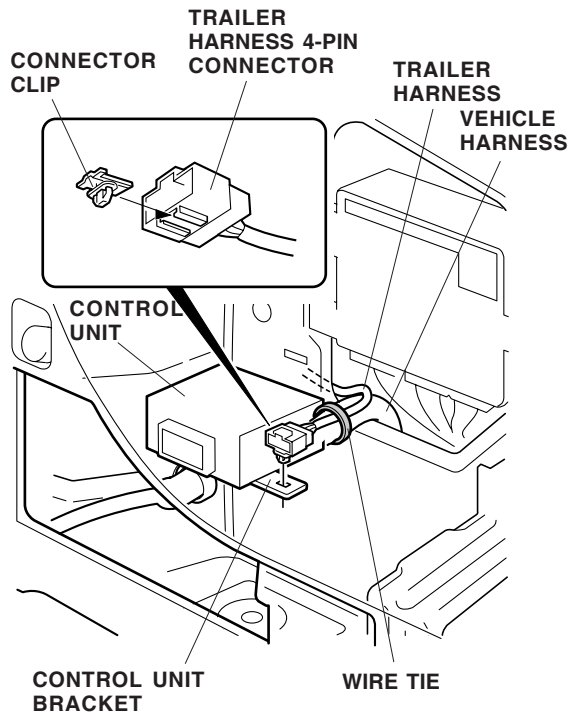

24. Secure the trailer harness with one wire tie to the vehicle harness.
25. Get the control unit harness. Plug the control unit harness 4-pin connector into the trailer harness 4-pin connector. Plug the control unit harness 12-pin connector into the control unit 12-pin connector.

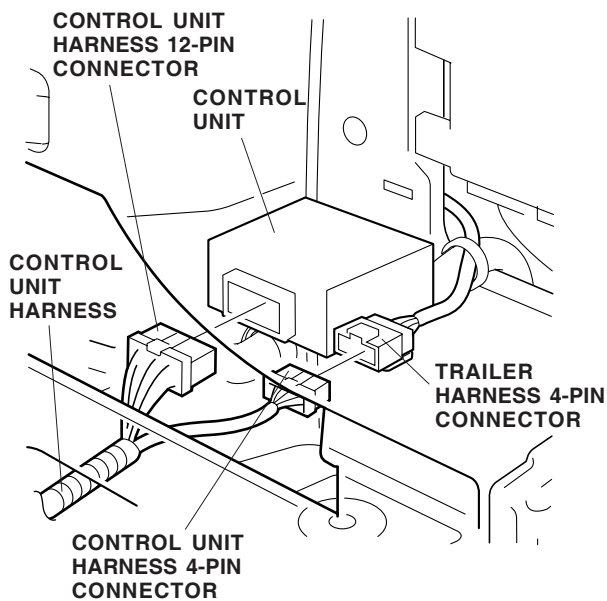

26. Attach the 7.5 A fuse label to the fuse case on the control unit harness.

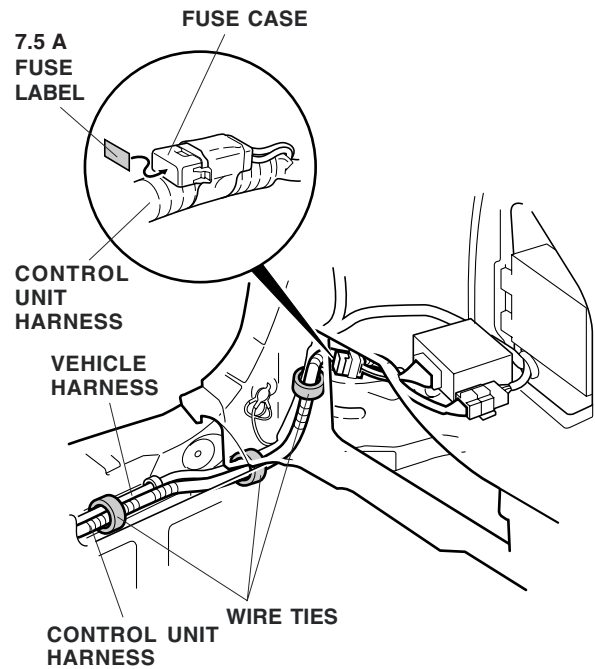

27. Route the control unit harness toward the right side of the vehicle, and secure the harness to the vehicle harness with three wire ties.
28. Continue routing the control unit harness along the rear of the vehicle and toward the right rear side trim panel. Secure the harness to the vehicle harness with four additional wire ties.

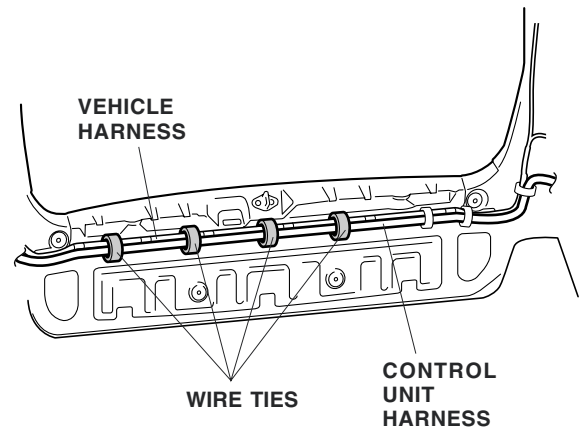

29. Pull out the weatherstrip at the right rear side trim panel. Remove the anchor bolt near the top of the side panel, and gently pull out on the right rear side trim panel to release the two clips.

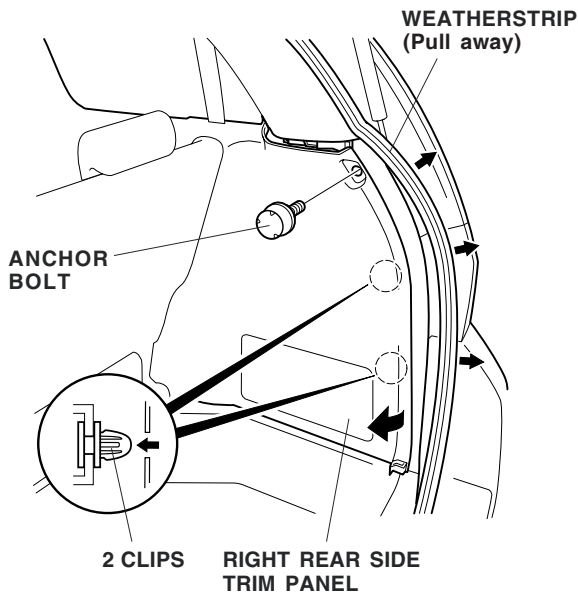

30. With an assistant gently pulling out on the right rear side trim panel, plug the control unit harness 8-pin connector into the rear junction box. Secure the control unit harness to the vehicle harness with two wire ties.

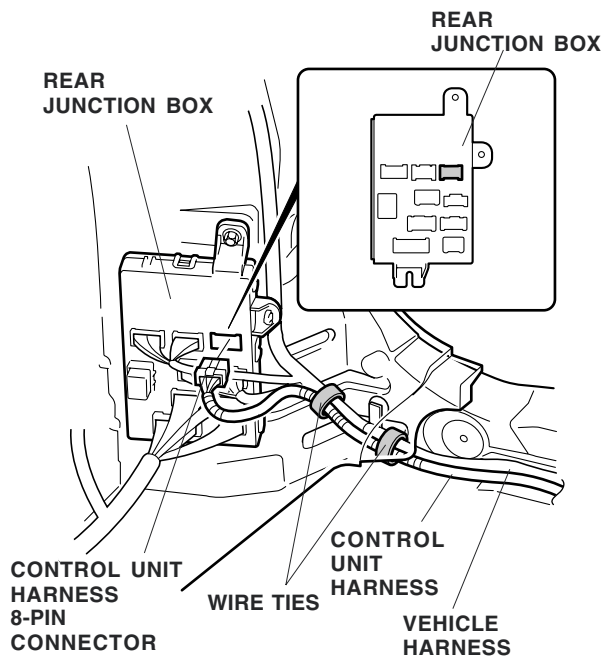

31. Reattach the right rear side trim panel, and reinstall the anchor bolt.

32. Remove the fuse cover from the right kick panel (two retaining tabs and one hook).

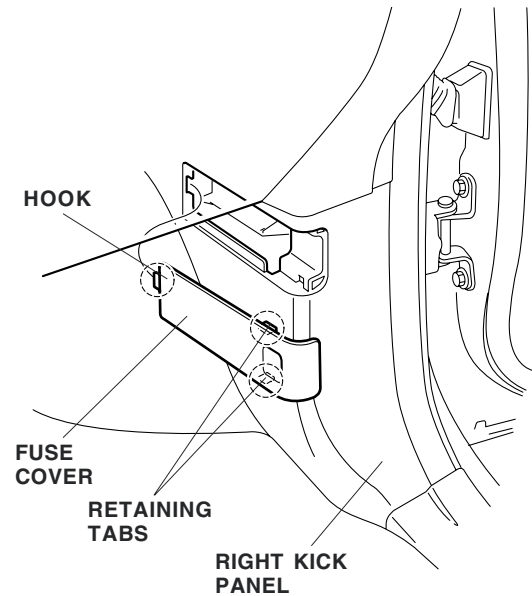

33. Install the 7.5 A fuse into the passenger's under-dash fuse/relay box at the location shown.

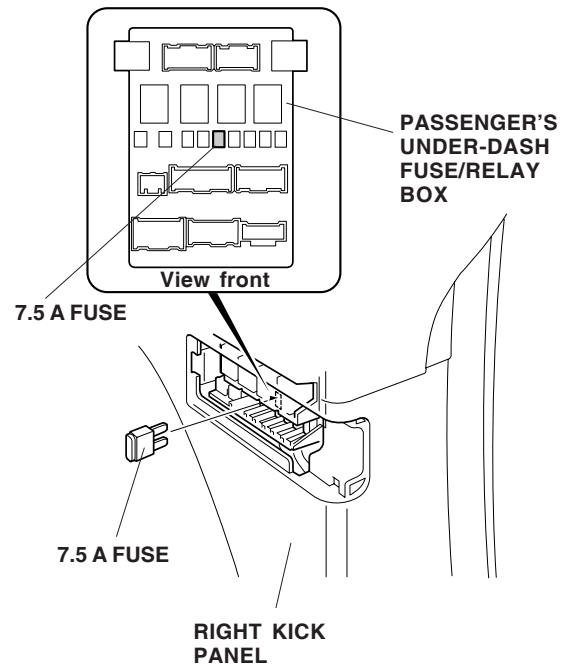

34. Attach the fuse label (7.5 A) to the fuse cover as shown.

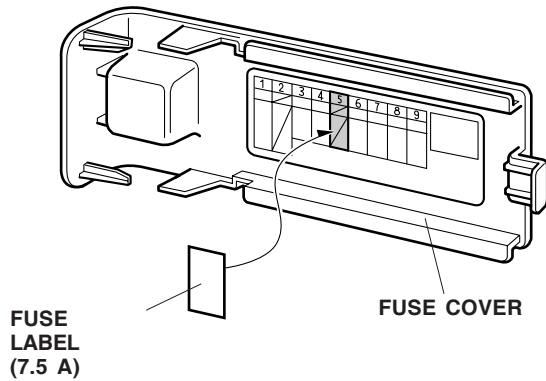

35. Reinstall the rear bumper.

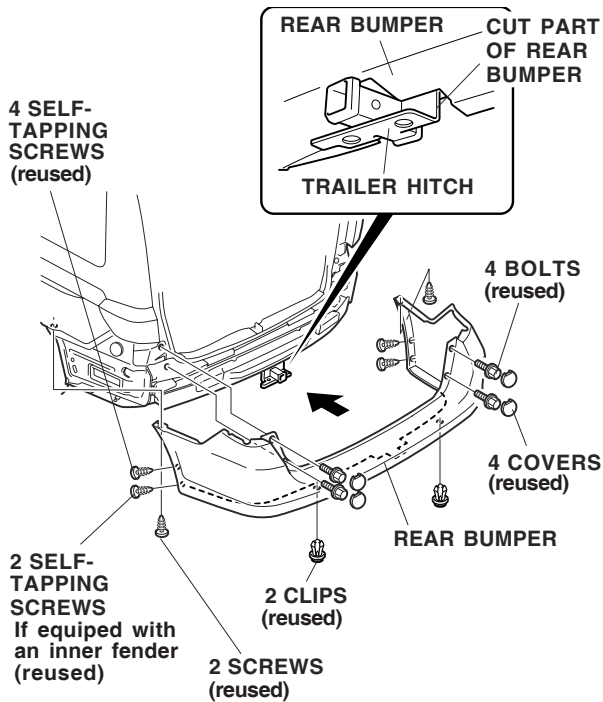

36. Slide the ball mount into the trailer hitch, and insert the retaining pin. Secure the retaining pin with the retaining clip.

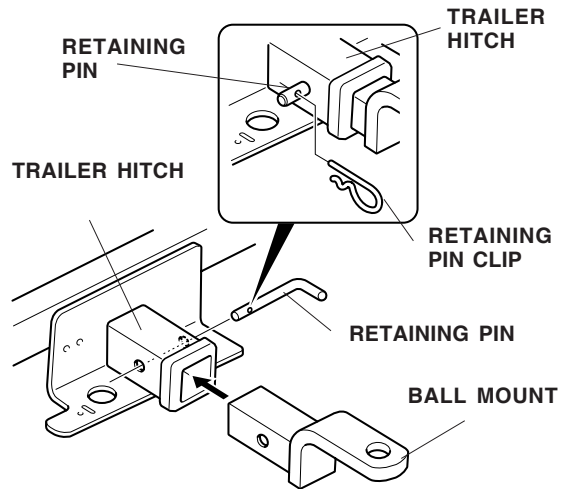

37. Reinstall all removed parts.

Installing the P/S and ATF Coolers

38. Remove the front bumper:

- Remove the radiator bulkhead cover.
- Remove the six clips and the two bolts along the bottom of the bumper.
- Remove the two clips from the top of the bumper (one on each side).
- Remove one screw from the inside of each fenderwell.
- Lift the bumper off of the hooks, and set the bumper on a blanket while you install the P/S and ATF coolers.

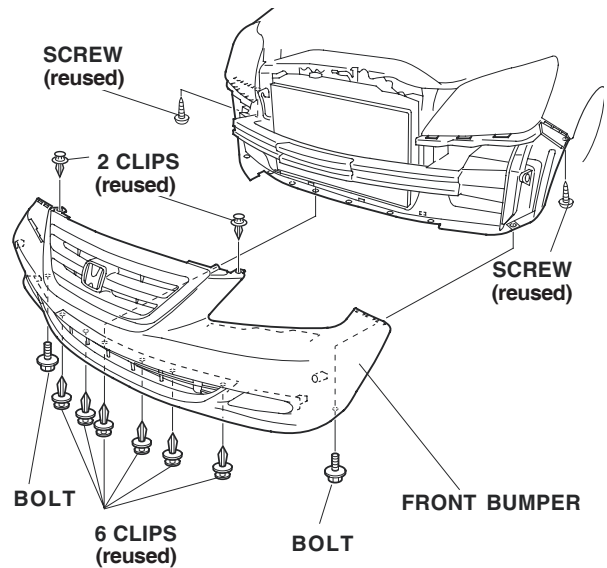

39. Remove the bumper beam (six bolts).

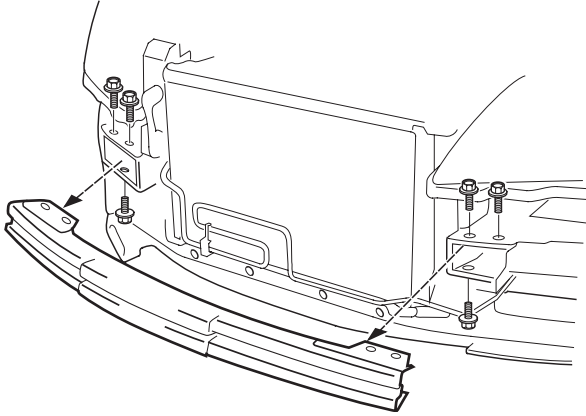

40. Under the vehicle, remove the front splash shield (17 clips).

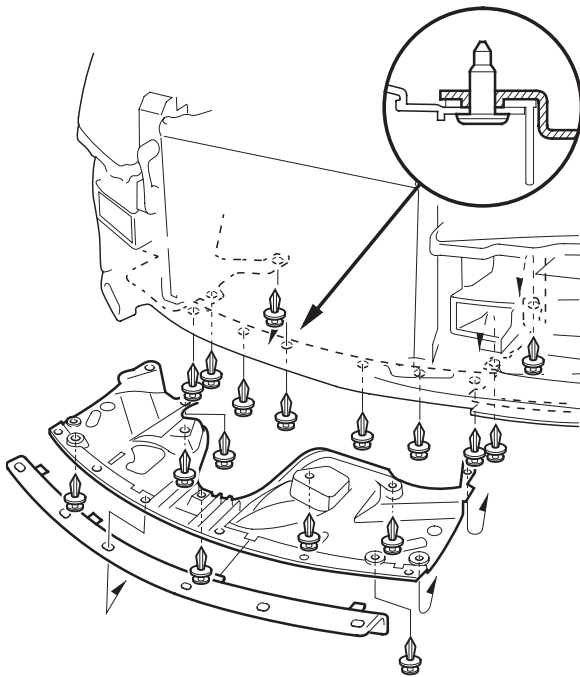

41. With a drain pan under the vehicle, remove the two bolts and two hose clamps that secure the existing P/S cooler. Release the clips, disconnect the P/S fluid lines, and remove the power steering cooler. Set the P/S cooler aside; it will not be reused.

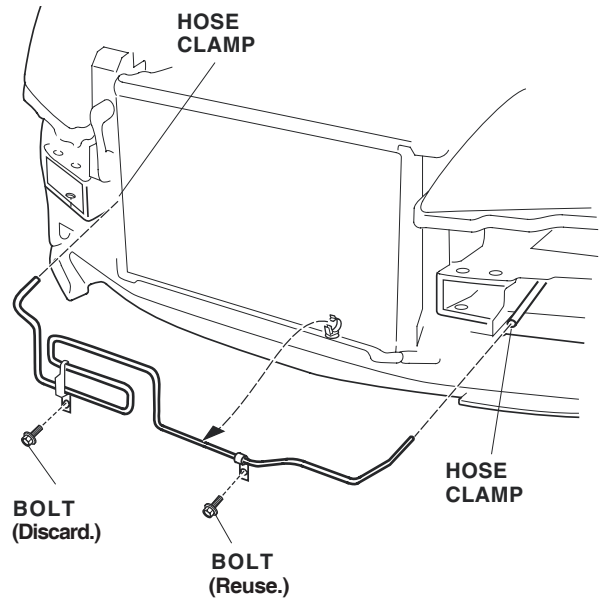

42. Position the heavy-duty P/S cooler on the radiator bulkhead, and attach the vehicle P/S lines to the cooler using the new hose clamps from the kit, and secure the clips. Attach the P/S cooler to the radiator bulkhead using the one 6 x 12 mm bolt and the 8 x 12 mm bolt from the kit.

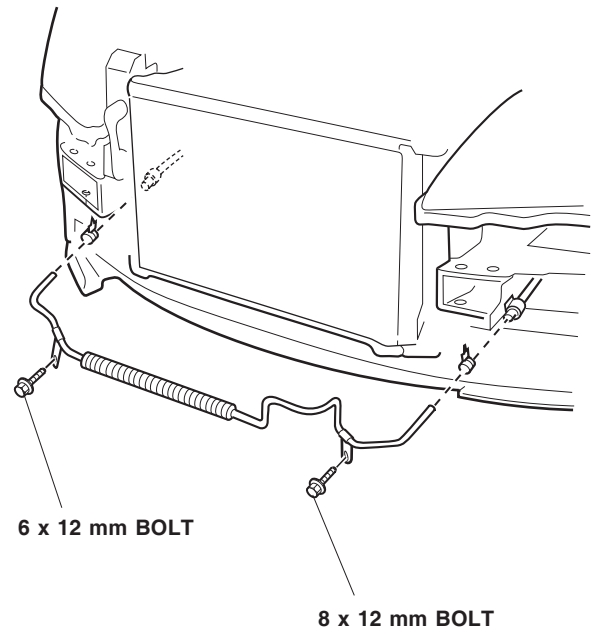

43. Get the new ATF cooler, the 370 mm hose, and the 320 mm hose. Install the 320 mm hose to the upper pipe of the ATF cooler, and secure the hose with one new hose clamp from the kit. Install the 370 mm hose to the lower pipe of the ATF cooler, and secure the hose with one new hose clamp from the kit.

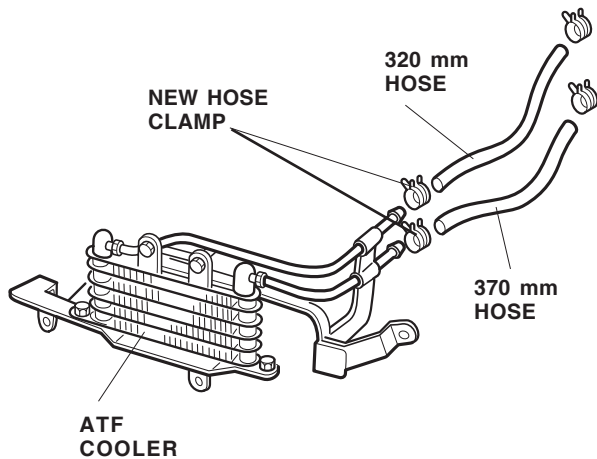

44. Route the hoses installed on the ATF cooler through the bulkhead, and position the ATF cooler on the front bulkhead. Align the bolt holes in the cooler with the holes in the bulkhead. Install two 6 x 12 mm washer-bolts, (one supplied, one reused) into the threaded holes to secure the ATF cooler, and install the remaining 6 x 12 mm washer-bolt (supplied) with nut into the non-threaded hole. Tighten all of the bolts securely.

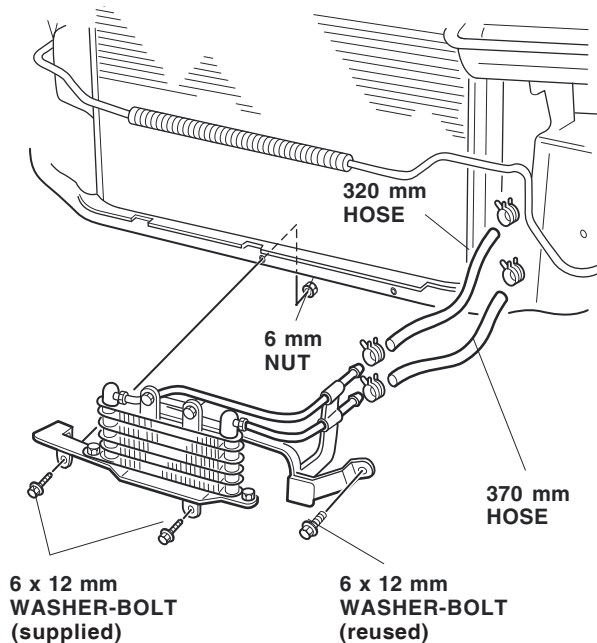

45. Remove and discard the existing ATF hose spacer and the two hose clips. Remove and discard the ATF feed line hose (two hose clamps).

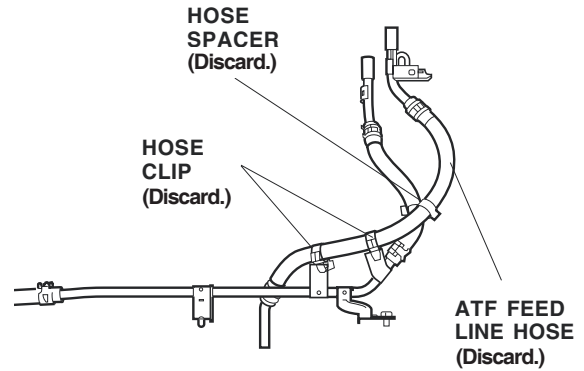

46. Install the upper hose (320 mm) from the ATF cooler to the ATF feed line using one new hose clamp. Make sure the new clamp is installed 7 mm from the end of hose.

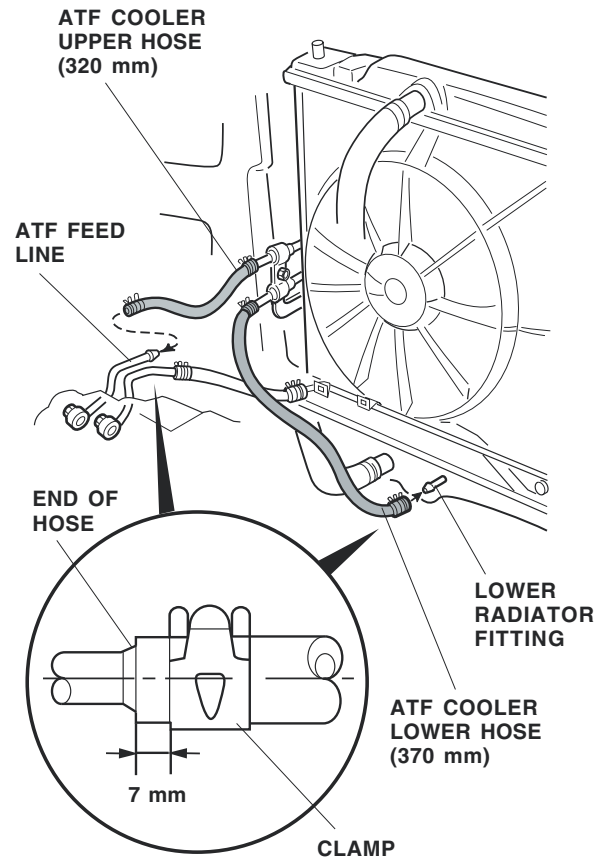

47. Install the lower hose (370 mm) from the ATF cooler lower hose to the lower radiator fitting using one new hose clamp. Make sure the new clamp is installed 7 mm from the end of hose.

48. Get the new ATF hose (220 mm), and the remaining two hose clamps. Remove and discard the existing ATF return hose and clamps, and install the new ATF return hose and clamps in its place. Make sure the new clamps are installed 7 mm from the end of hose ends.

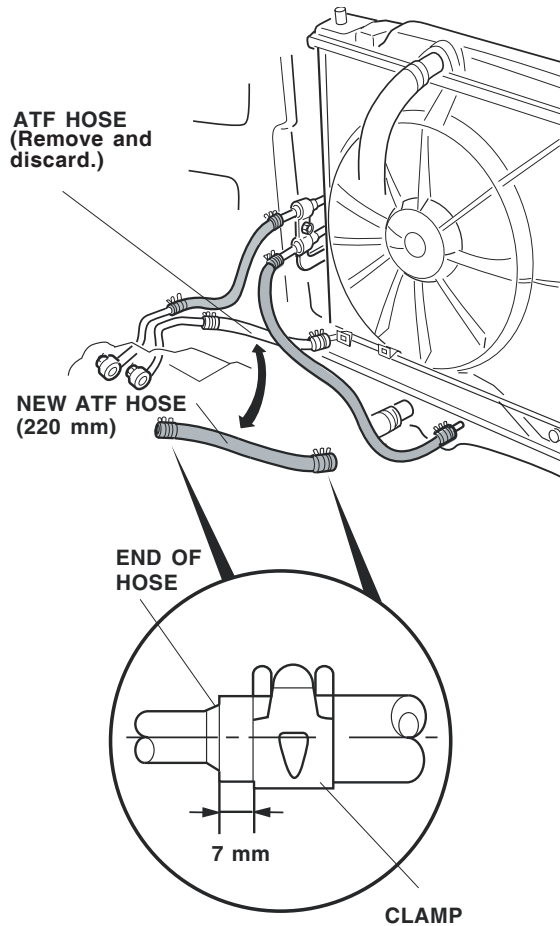

49. Attach the new ATF hose spacer between the two hoses at the white line painted on the ATF hose.

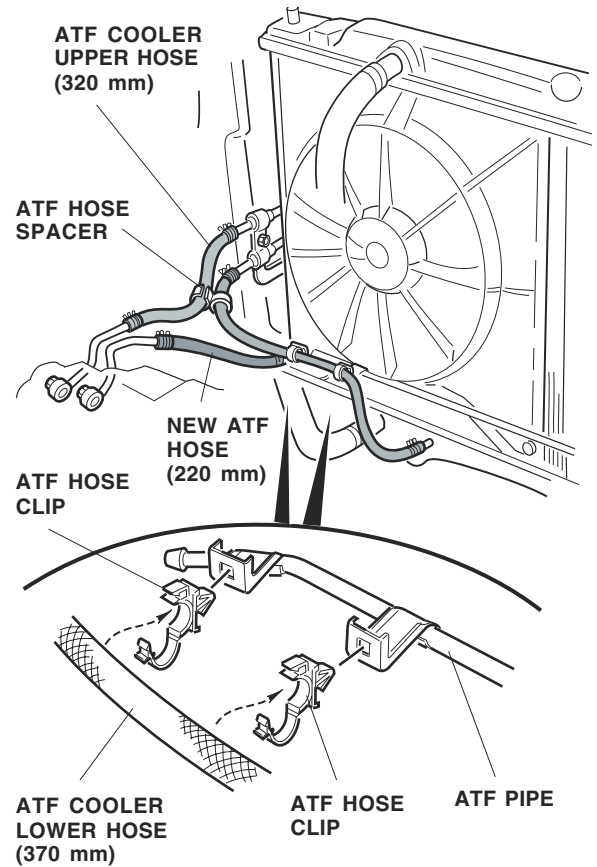

50. Attach the two new hose clips to the brackets on the ATF pipe. Secure the lower cooler line to the ATF pipe using the hose clips.

51. Position the air duct on the radiator bulkhead, and install the four clips to secure the air duct.

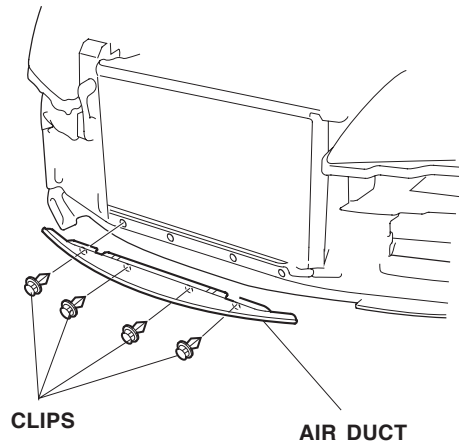

52. Reinstall the front bumper beam, and torque the bumper beam bolts to 22 lb-ft (26 N·m).
53. Reinstall the splash shield, and the front bumper.
54. Reconnect the negative cable to the battery.
55. Enter the customer's radio anti-theft code, and reset the audio presets.
56. Reset the clock.
57. Reinstall all removed parts.

NOTE: Whenever the battery is disconnected, the driver's window AUTO function is disabled.

58. Start the engine. Push down on the driver's window switch until the window is fully open.
58. Pull up on the driver's window switch to close the window completely, then hold the switch for 2 seconds or more.
60. Lower and raise the window to check the operation of the driver's window AUTO function.
61. Start the vehicle and check for leaks; repair as necessary.
62. Check the ATF and the P/S fluid levels and adjust them as necessary.
63. Attach the hang tag around the rear view mirror.

NOTE: After about 620 miles (1,000 km), recheck the torque of the trailer hitch bolts.

Give a copy of this page to your customer.

Installing the Receiver Cover

Whenever you remove the hitch pin clip, the hitch pin, and the ball mount, store them securely in the cargo area. Install the receiver cover into the opening at the end of the trailer hitch. When you reinstall the ball mount, store the receiver cover in the cargo area. After the first 620 miles (1,000 km) of towing, have your Honda dealer recheck the tightness of the trailer hitch bolts.

