



## INSTALLATION INSTRUCTIONS

Accessory

MOONROOF VISOR  
08R01-SHJ-102

Application

2008 ODYSSEY

Publications No.

All 38164-38746

Issue Date

JAN 2008

Put this information in the glove box with the vehicle owner's manual.

### PARTS LIST

Moonroof visor

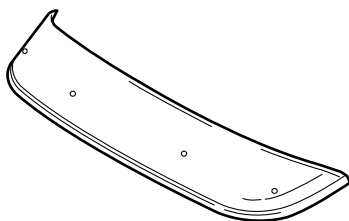

2 Front brackets A  
(long)

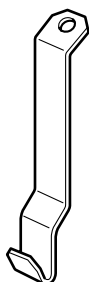

2 Side brackets B  
(short)

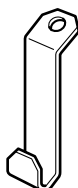

4 Screws



4 Nuts



4 Protective tapes



### TOOLS AND SUPPLIES REQUIRED

Phillips screwdriver

10 mm Combination wrench

Felt-tip pen

Tape measure

Isopropyl alcohol

Shop towel

Torque Screwdriver

Available through the Honda Tool and Equipment Program at 888-424-6857:

Torque screwdriver Model No.: CDI401SM

### INSTALLATION

1. Clean and wax the roof area to be covered with a high-quality paste wax.
2. Open the moonroof.
3. Measure the distance between points A and B, and divide that measurement in half to find the center of the moonroof opening (C). Mark the roof at the center (C) with a felt-tip pen.

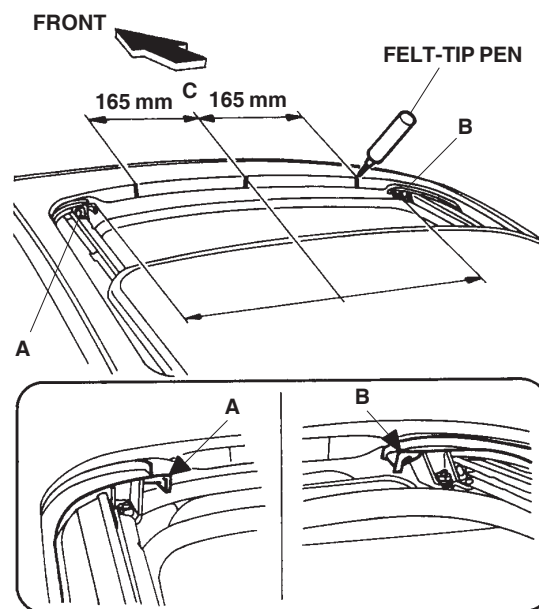

4. From the center point (C), measure 165 mm to each side, and mark the roof with a felt-tip pen.

5. Locate the panel joint on the right side of the moonroof opening. Measure 20 mm to the front of the vehicle, and make a mark on the roof. Repeat on the other side of the moonroof opening.

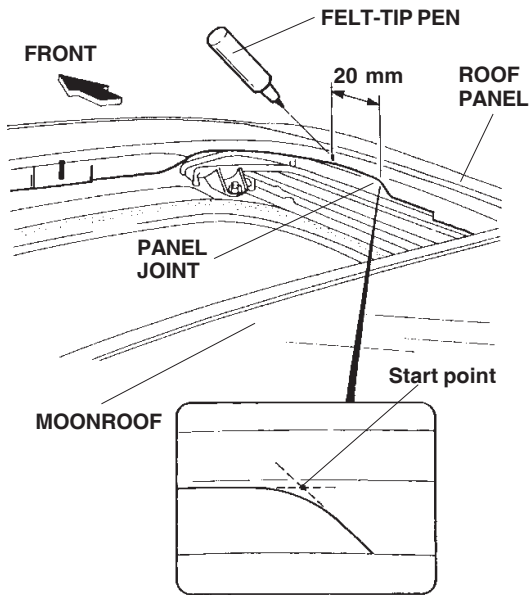

6. Using isopropyl alcohol on a shop towel, clean the roof at each mark you've made but don't wipe off the marks.
7. Remove the adhesive backing from the protective tapes, and attach them to the roof at the marks you made. Wrap 6 mm of the protective tape around the lip of the moonroof opening.

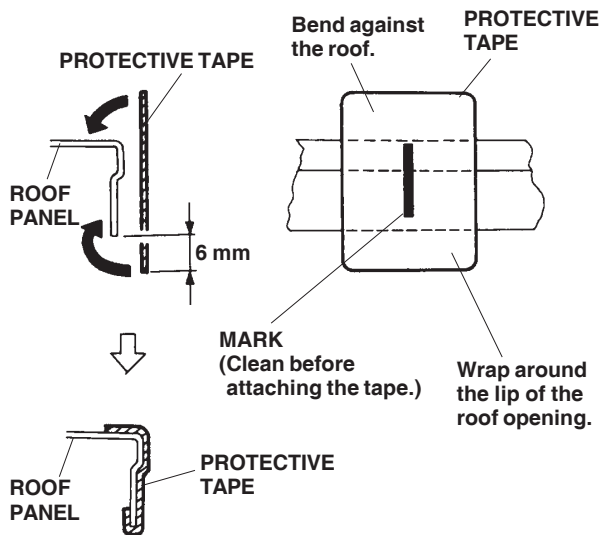

8. Place the two front brackets A into position over the front protective tapes by sliding them along the lip of the roof opening. Set the moonroof visor on the vehicle roof, in front of the moonroof opening, and adjust its position so the holes in the visor are aligned with the protective tapes.

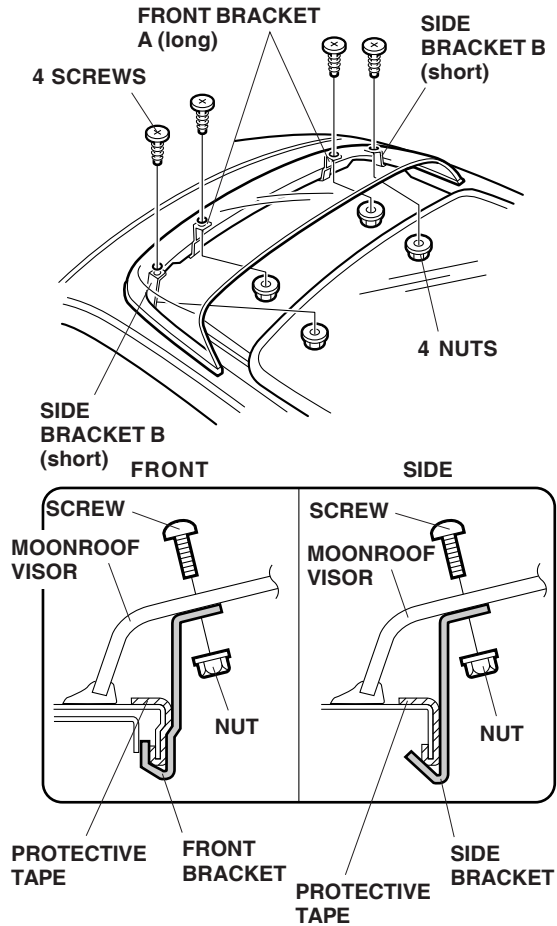

9. While holding the visor in place, install two screws and two nuts into the brackets A. Do not tighten the screws yet. Install the brackets B over the side protective tapes, then install two screws and two nuts into the brackets B.

10. Position the moonroof visor with equal spacing on all sides. Check that the rubber seal is not twisted or rolled under the visor.

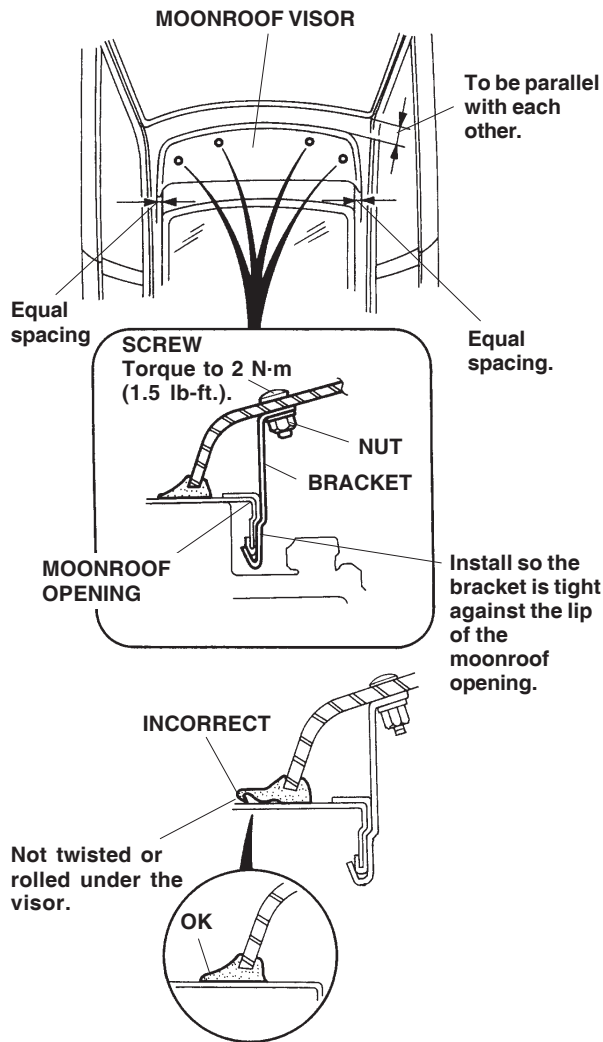

11. Torque the screws to 2 N·m (1.5 lb-ft.), alternating between sides. To prevent damage to the resin nuts, do not overtighten the screws.

## CARE OF YOUR MOONROOF VISOR

- To avoid damaging the surface, never use ammonia-based cleaners or solvents to clean your moonroof visor.
- Clean with a solution of mild dishwashing soap and water using a soft cloth or chamois.
- To remove fine scratches and restore the original luster, use Meguiar's Mirror Glaze plastic cleaner and polish or an equivalent high-quality plastic cleaner.