



## INSTALLATION INSTRUCTIONS

Accessory  
**PARKING SENSORS**

Application  
**2020 INSIGHT**

Publications No.  
**VERSION 1**  
Issue Date  
**JULY 2019**

### PARTS LIST

**Parking Sensor Attachment Kit**  
**P/N 08V67-TXM-100A**

Parking sensor harness

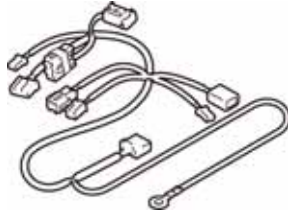

Floor harness

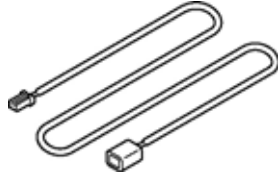

Subharness

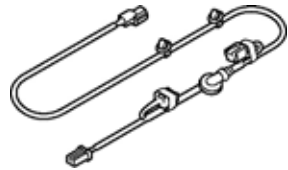

Front bumper harness

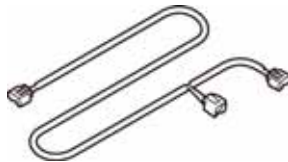

Rear bumper harness

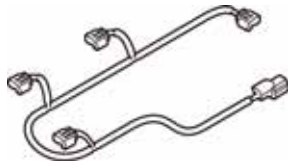

Control unit



Control unit bracket



Switch



34 Wire ties



18 Aluminum tapes

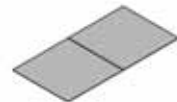

2 Retainers A  
(Identification mark: 0DEG: 1.2)



4 Retainers B  
(Identification mark: 0DEG: 0.8)



6 Rubber spacers



3 Primers

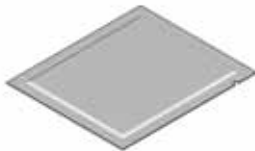

2 Alcohol wipes



Fuse label



Nut



Connector holder



Accessory user's information manual



## Sensors Kit P/N 08V67-TVA-100K

6 Sensors



### TOOLS AND SUPPLIES REQUIRED

Phillips screwdriver  
10 mm, 12 mm, and 13 mm Open end wrenches  
10 mm Socket  
Pushpin  
Ratchet  
3 mm, 6 mm, and 8.5 mm Drill bits  
Eye protection (face shield, safety goggles, etc.)  
File  
Masking tape  
5 mm Hex wrench  
Blanket  
Isopropyl alcohol  
Shop towel  
Felt-tip pen  
Drill  
Diagonal cutters  
Utility knife  
Scissors  
Torque wrench  
Ruler  
Plate  
Tape measure

*The following tools are available through the Honda Tool and Equipment Program. On the iN, click on Service > Service Bay > Tool and Equipment Program, then enter the number under "Search." Or, call 888-424-6857.*

- Trim Tool Set (T/N SOJATP2014)
- Plastic Trim Tool (T/N SILTRIMTL10)
- 16 mm Punch Tool (T/N 07AAH-TZ5A100)

## Illustration of the Parking Sensors Installed on the Vehicle

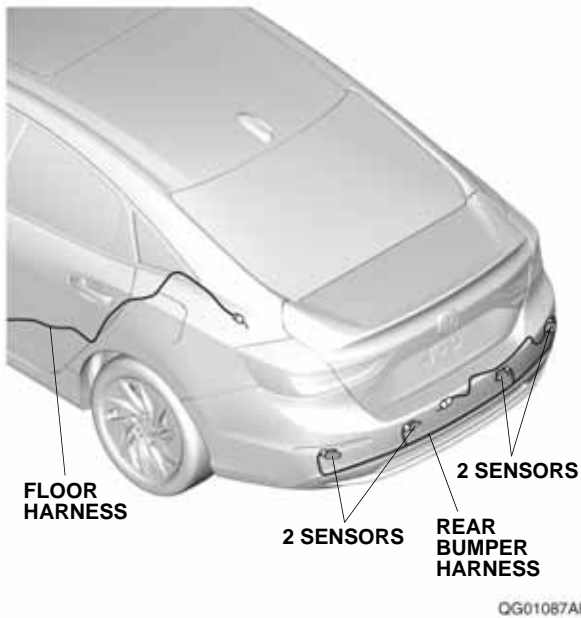
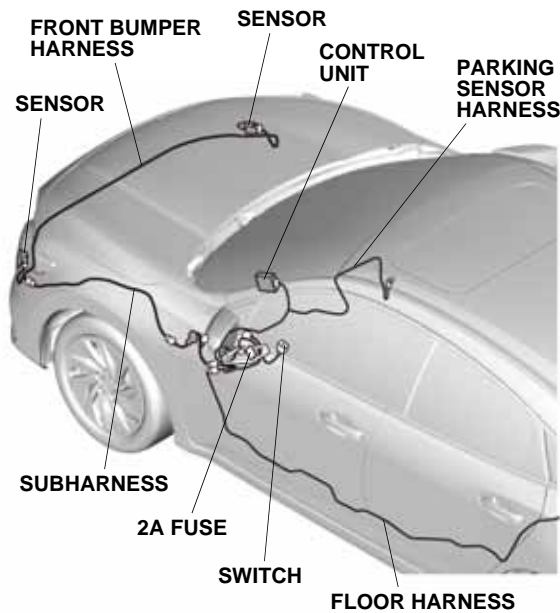

## INSTALLATION

**Customer Information:** The information in this installation instruction is intended for use only by skilled technicians who have the proper tools, equipment, and training to correctly and safely add equipment to your vehicle. These procedures should not be attempted by “do-it-yourselfers.”

**NOTE:** If you turn the power switch to ON during installation, an indicator come on in the instrument panel. Once, you finish installation and carry out the initial settings, the indicator will go off.

1. Remove the right side panel, and disconnect the negative cable from the battery.  
**NOTE:** Wait 3 minutes after turning the power switch to OFF before disconnecting the battery.

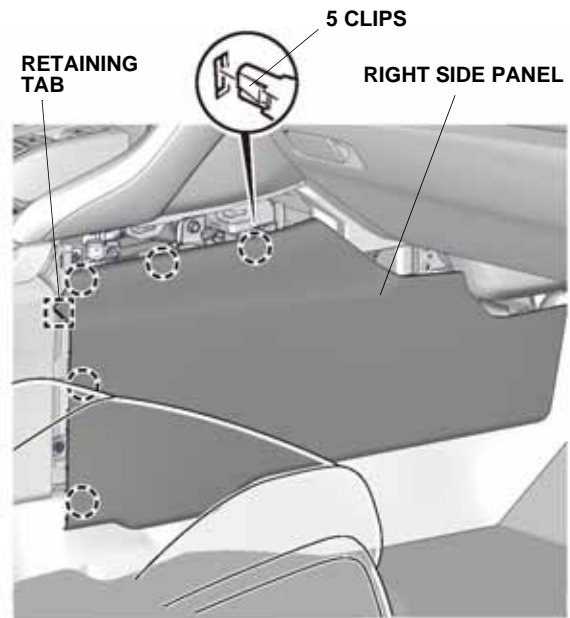

CG80701BT

2. Pull away the door opening seal, and remove the passenger's dashboard side lid.

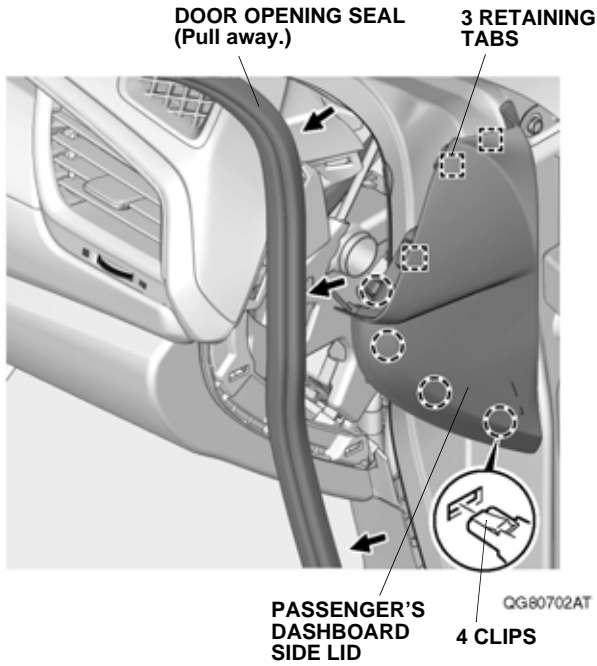

3. Remove the passenger's under cover.

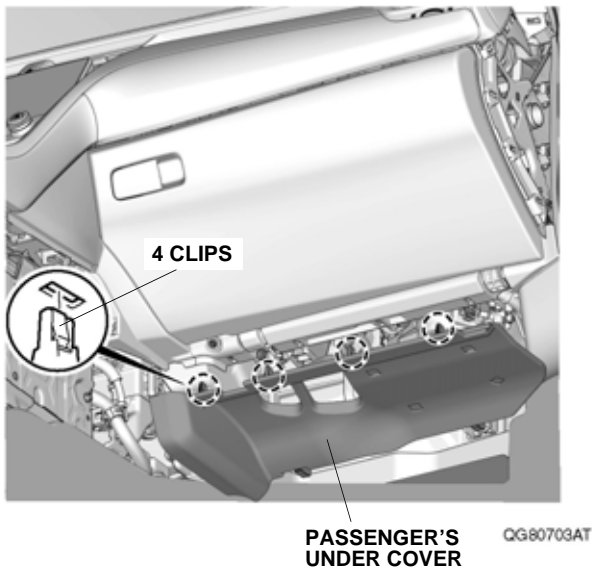

4. Open the glove box, push inward on the glove box stops, and remove the glove box.

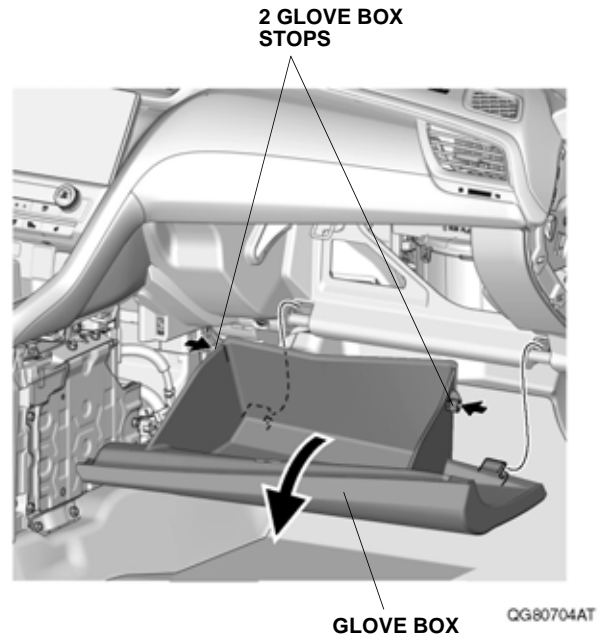

5. Remove the glove box cover.

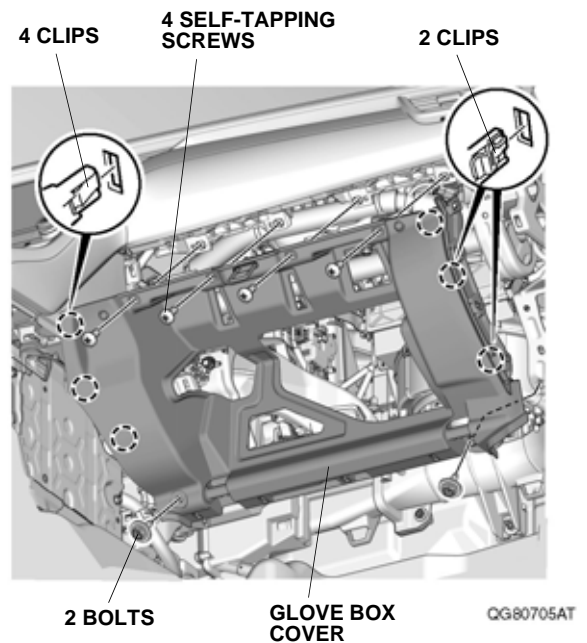

6. Remove the driver's dashboard lower cover, and unplug the vehicle connectors.

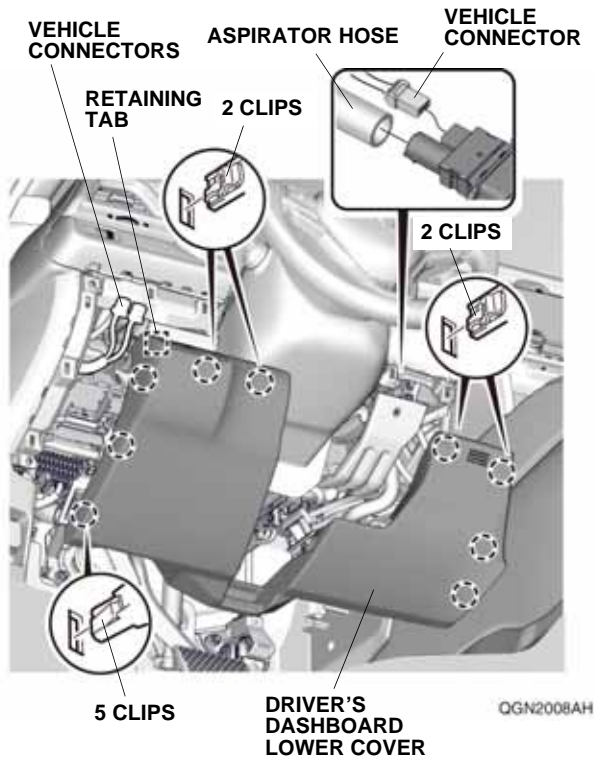

7. Pull away the door opening seal, and remove the driver's dashboard side lid.

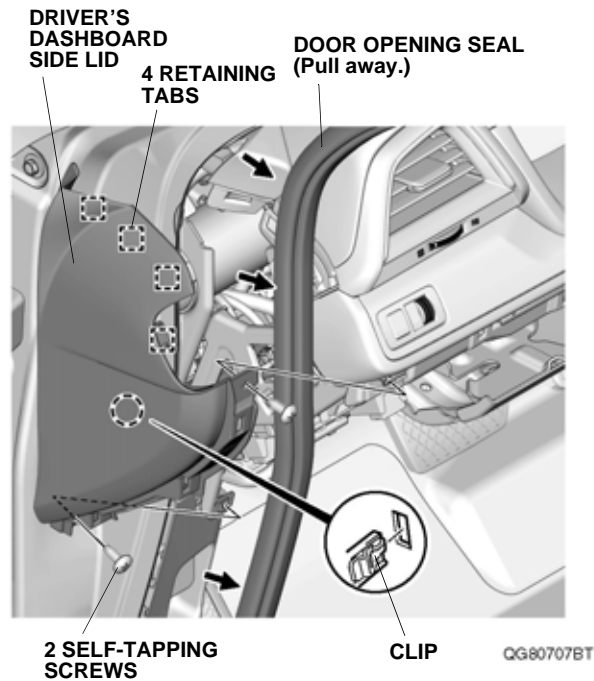

8. Remove the driver's front door sill trim.

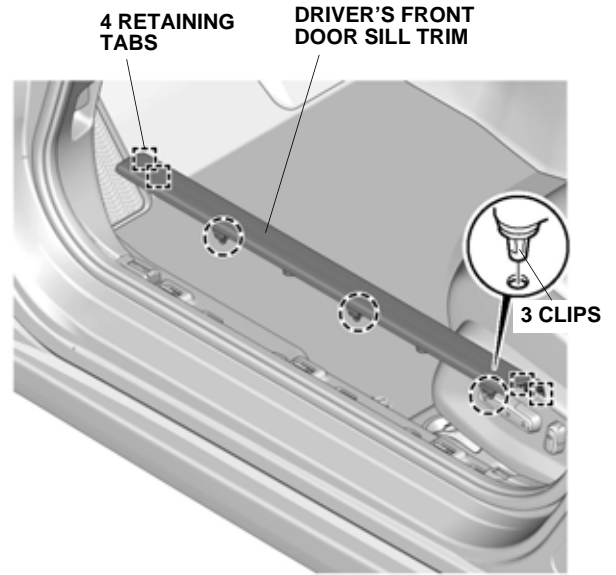

9. Pull away the door opening seal, and remove the driver's kick panel.

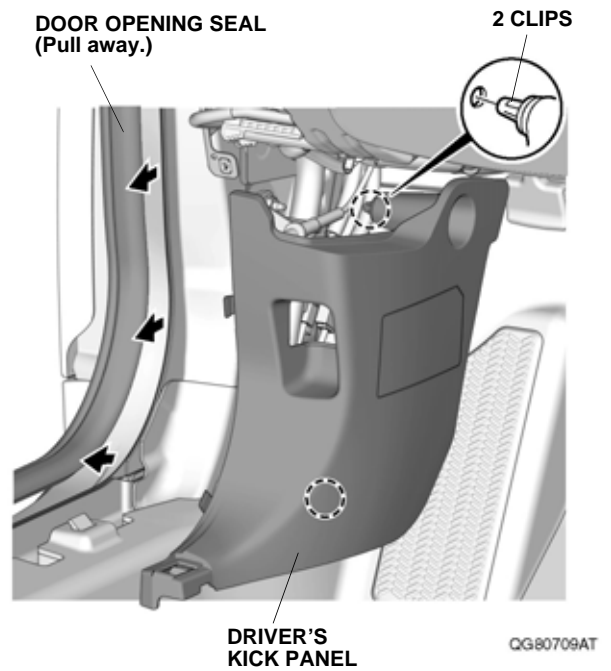

10. Apply masking tape as shown.

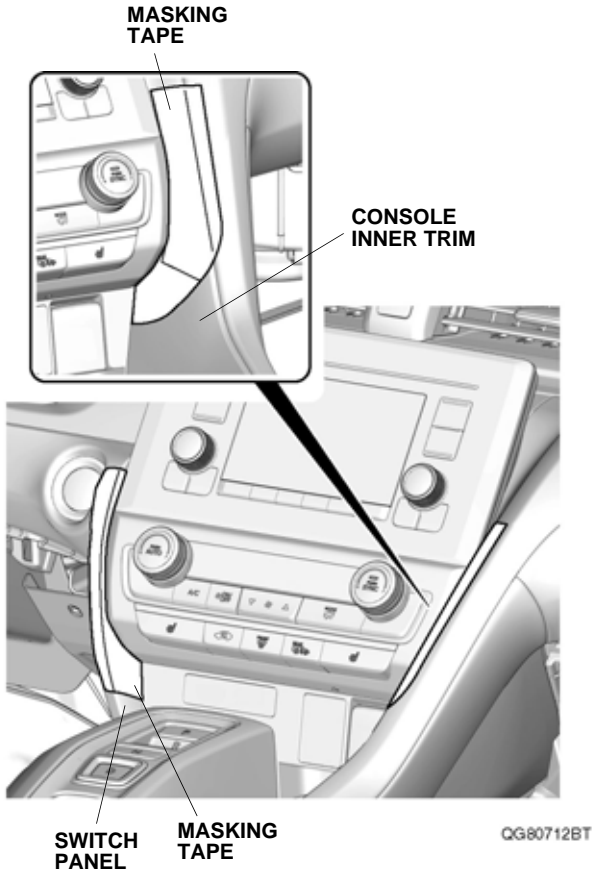

11. Remove the A/C control unit, and unplug the vehicle connector.

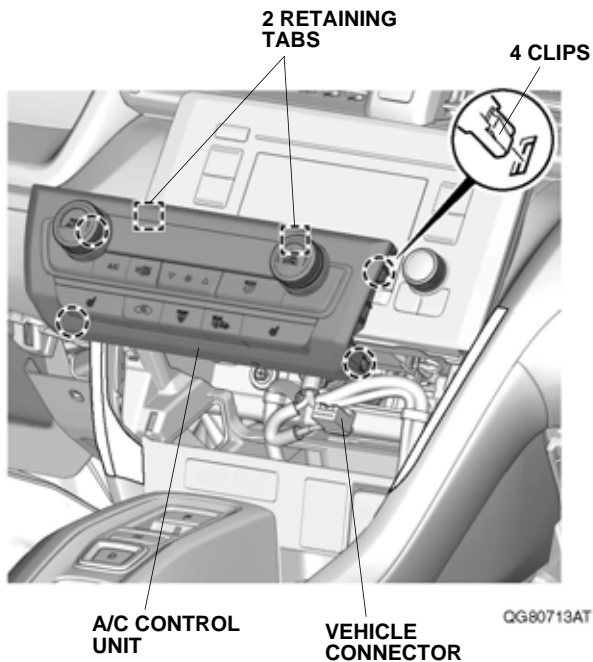

12. Remove the audio unit, and unplug the vehicle connectors.

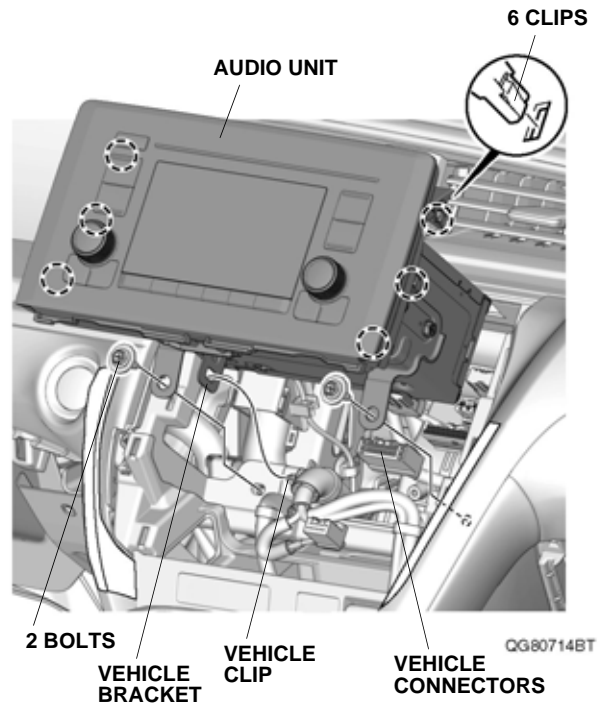

13. Remove the bolt from the rear seat cushion. Pull out the two clips to release the hooks, and release the rear seat cushion.

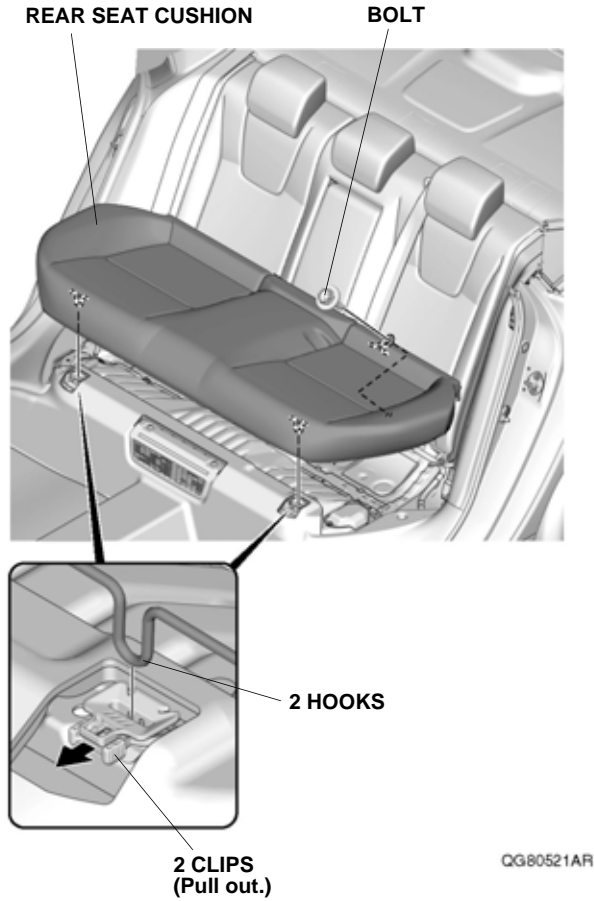

14. Remove the left rear door sill trim.

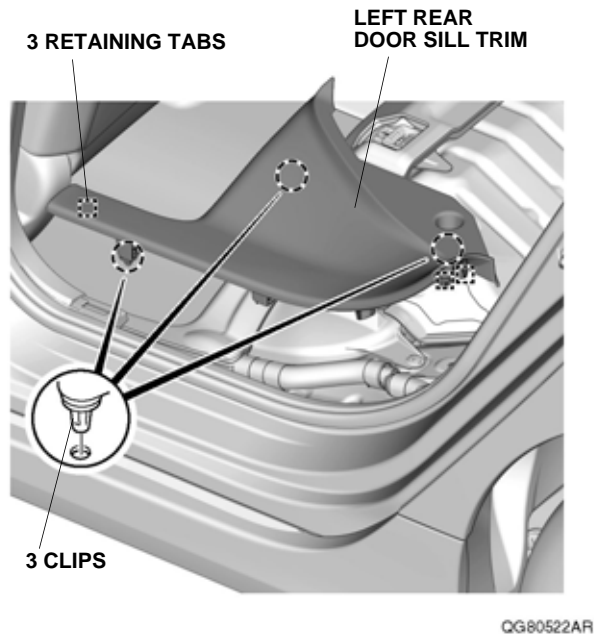

15. Pull away the door opening seals, and remove the left B-pillar lower trim.

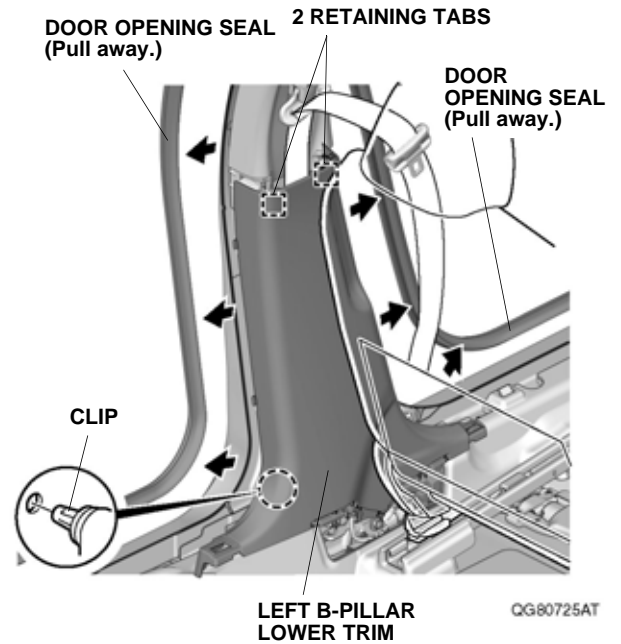

16. Pull the levers, and fold the rear seat-backs forward.

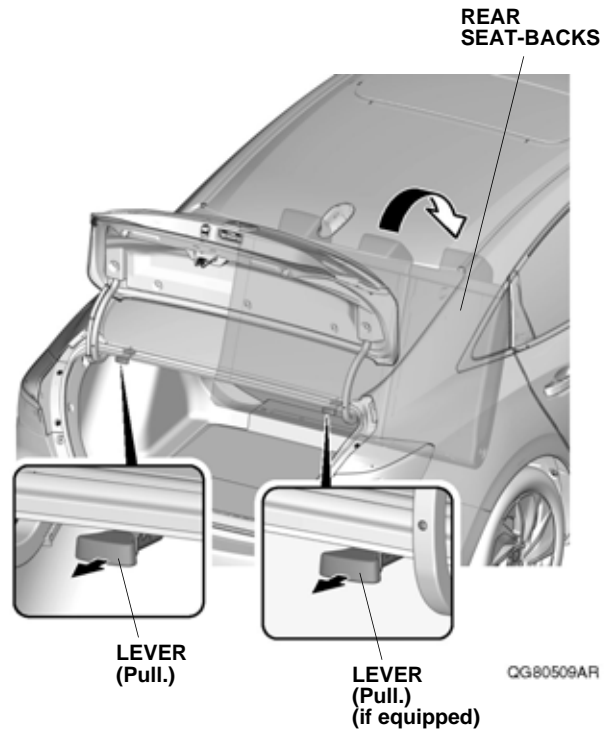

17. Pull away the door opening seal, and remove the left rear seat side bolster.

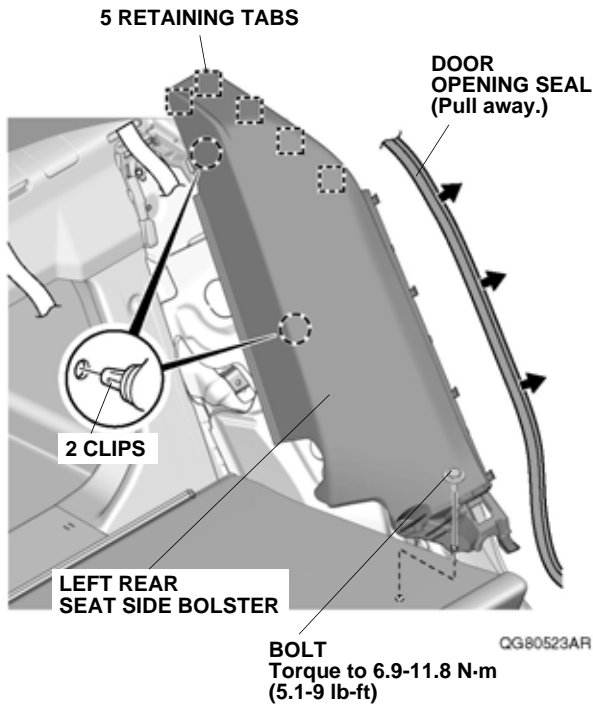

18. Remove the spare tire lid.

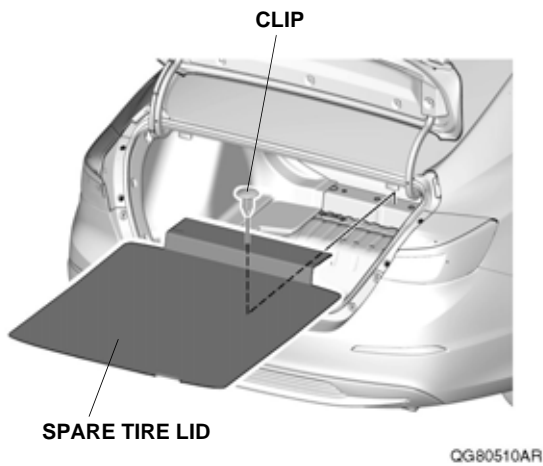

If the vehicle is equipped with a spare tire, continue with step 19; otherwise, go to step 20.

19. Remove the tool box.

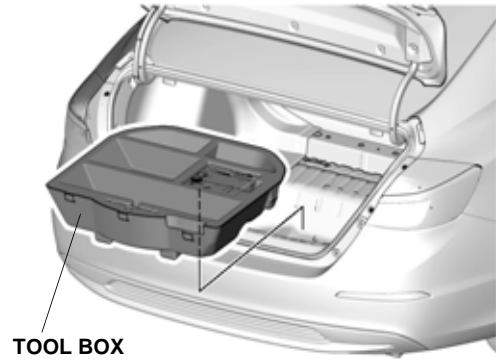

20. Pull away the weatherstrip, and remove the rear trim panel.

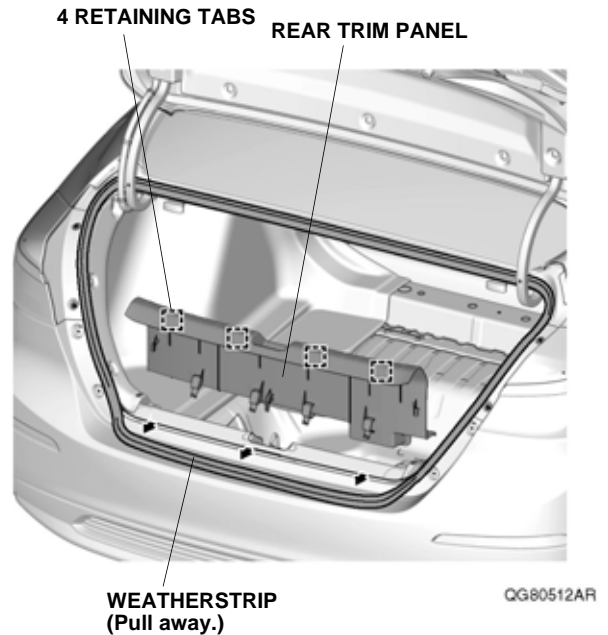



21. Pull away the weatherstrip, and remove the left trunk side trim panel.

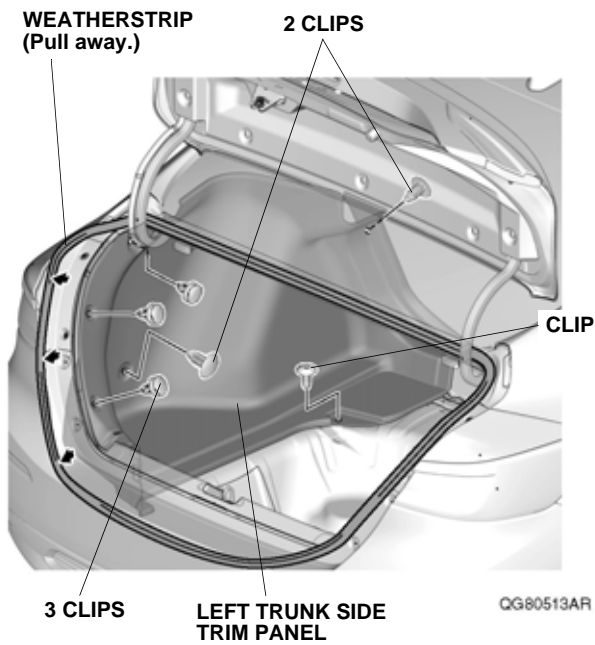

22. Remove the rear bumper.
- Apply masking tape as shown.

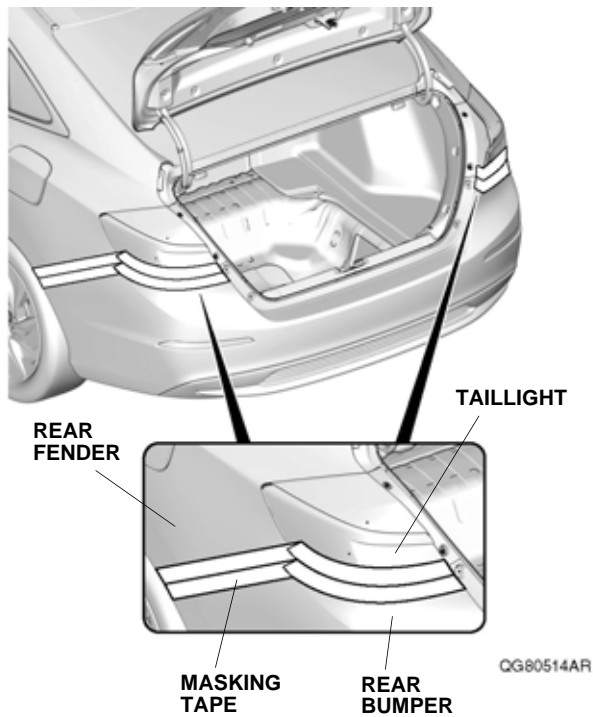

- Remove the five clips, four bolts, and six self-tapping screws.

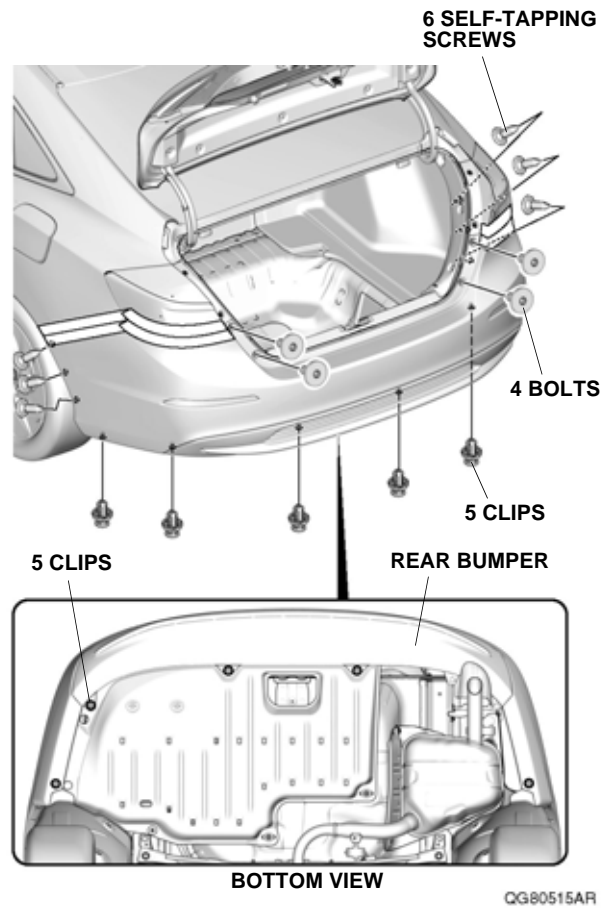

- With the help of an assistant, release the eight retaining tabs on each side.

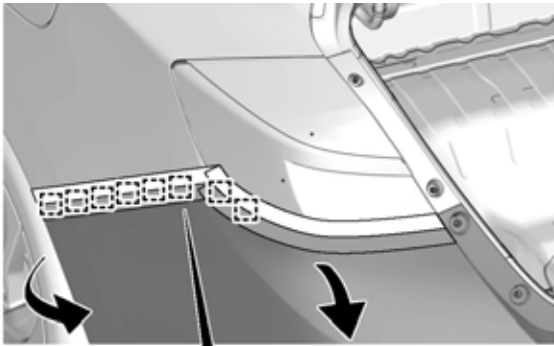

8 RETAINING TABS

QG80516AR

- With the help of an assistant, remove the rear bumper. Place the rear bumper on a blanket to prevent damage.

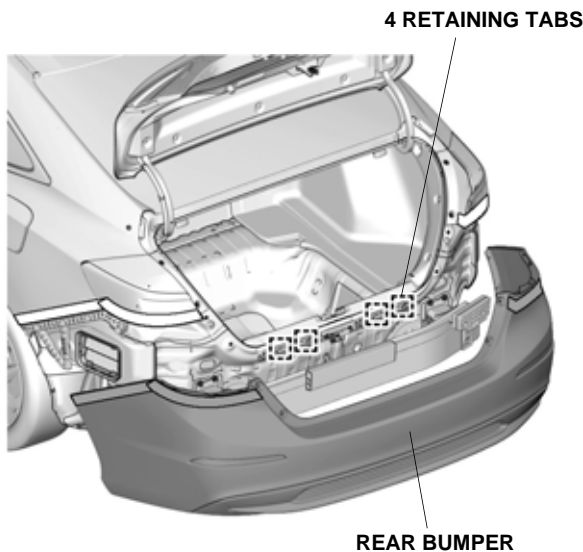

4 RETAINING TABS

REAR BUMPER

QG80517AR

23. Remove the front bumper.
- Apply masking tape as shown.
  - Wrap a shop towel around the hood latch.

HOOD LATCH  
(Wrap with a shop towel.)

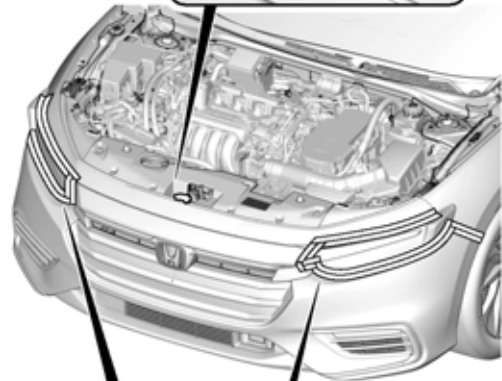

FRONT FENDER

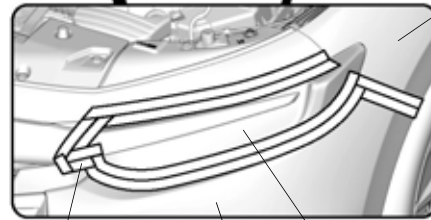

MASKING TAPE

HEADLIGHT

FRONT BUMPER

QG80501AR

- Remove the front bulkhead cover.

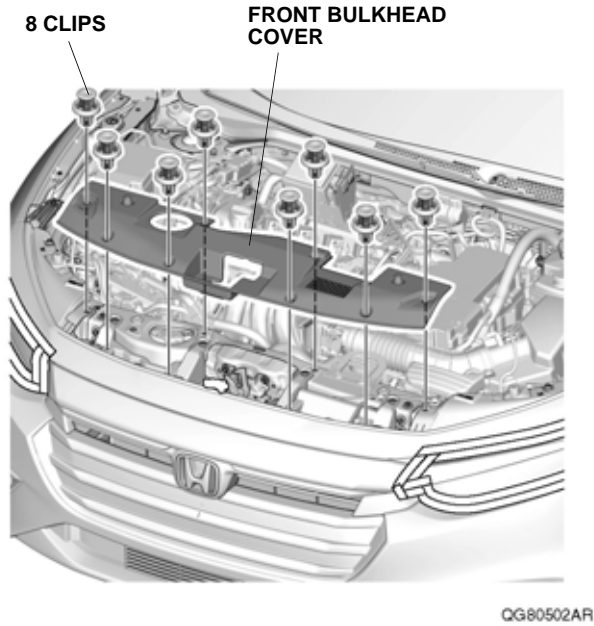

- Remove the millimeter wave radar cover.

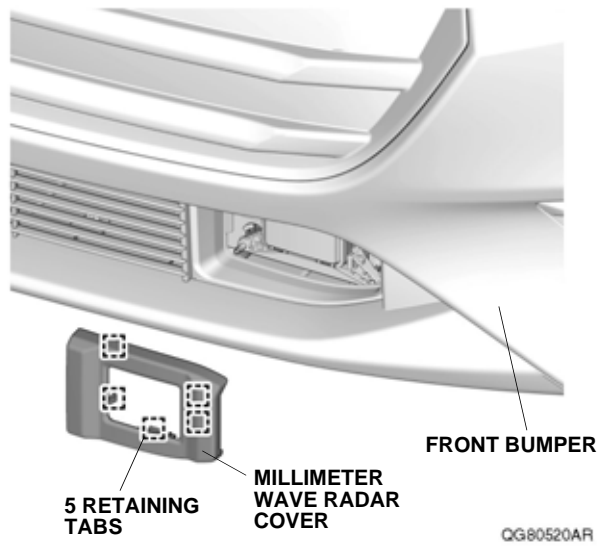

- Remove the two bolts and 12 clips.

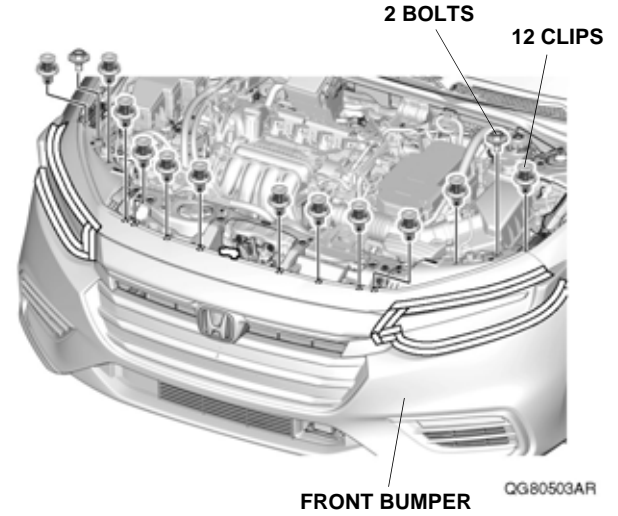

- Remove the four self-tapping screws, two hex bolts, and 11 clips.

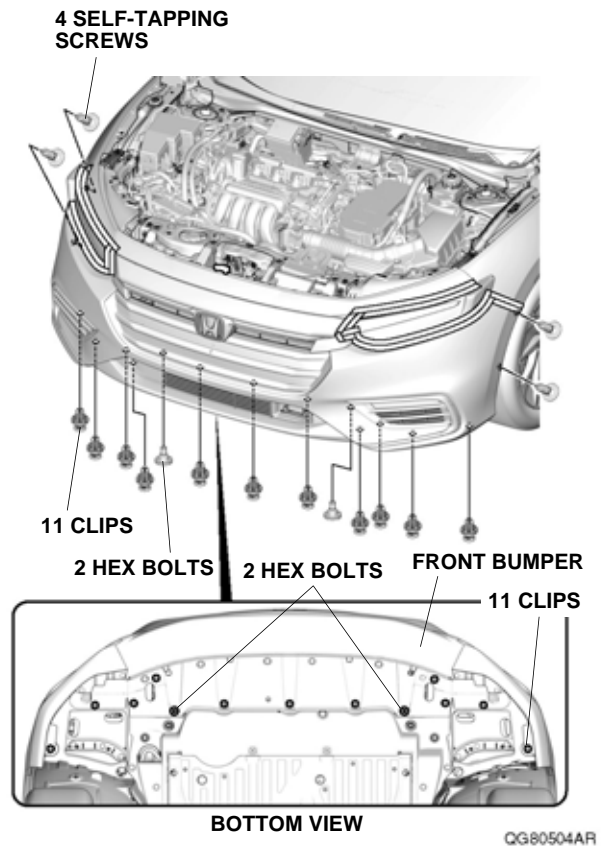

- With the help of an assistant, release the seven retaining tabs on each side.  
NOTE: Make sure you remove and release the retaining tabs as shown.

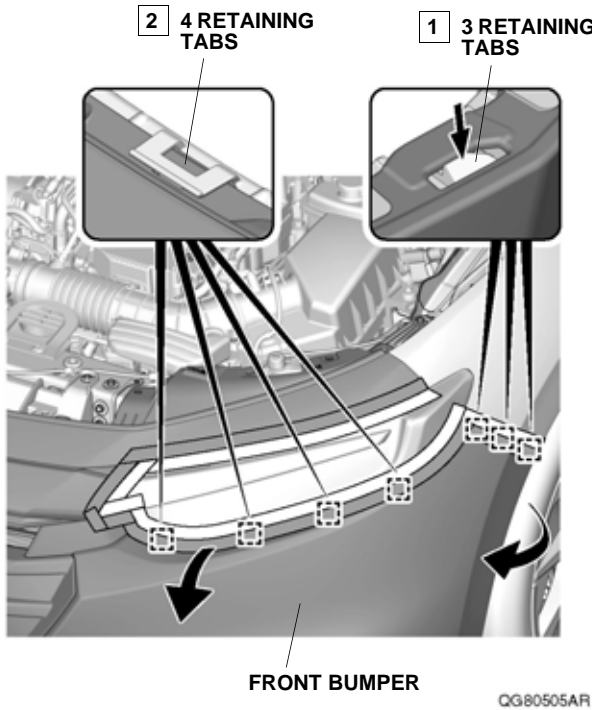

- With the help of an assistant, remove the front bumper using a plastic trim tool, and unplug the vehicle connectors (if equipped). Place the front bumper on a blanket to prevent damage.

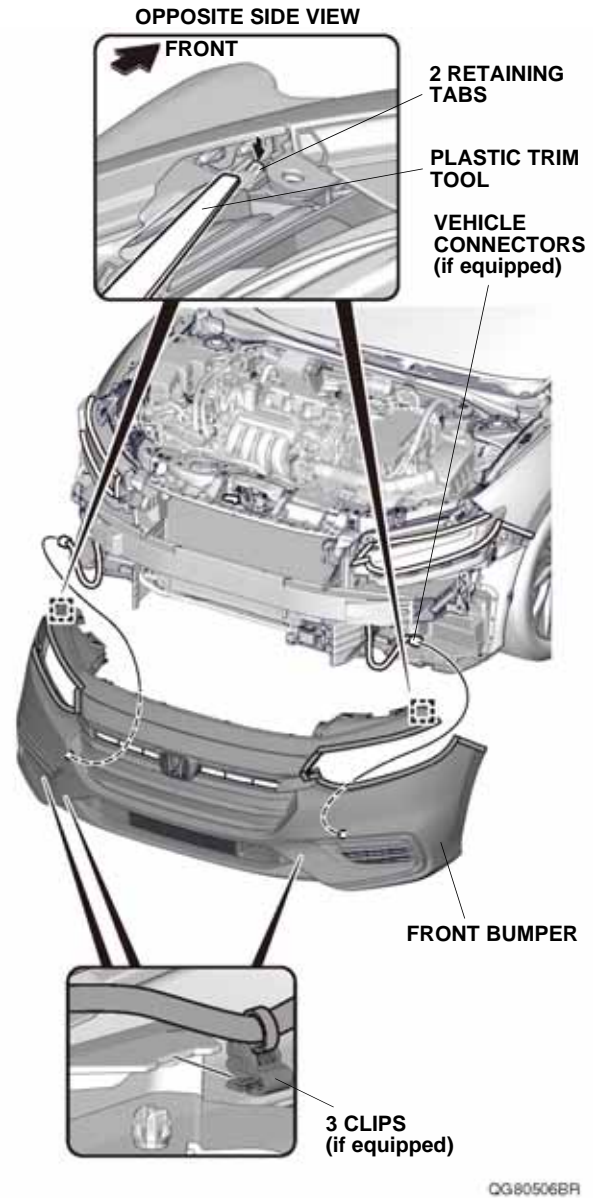

24. Release the left front inner fender.

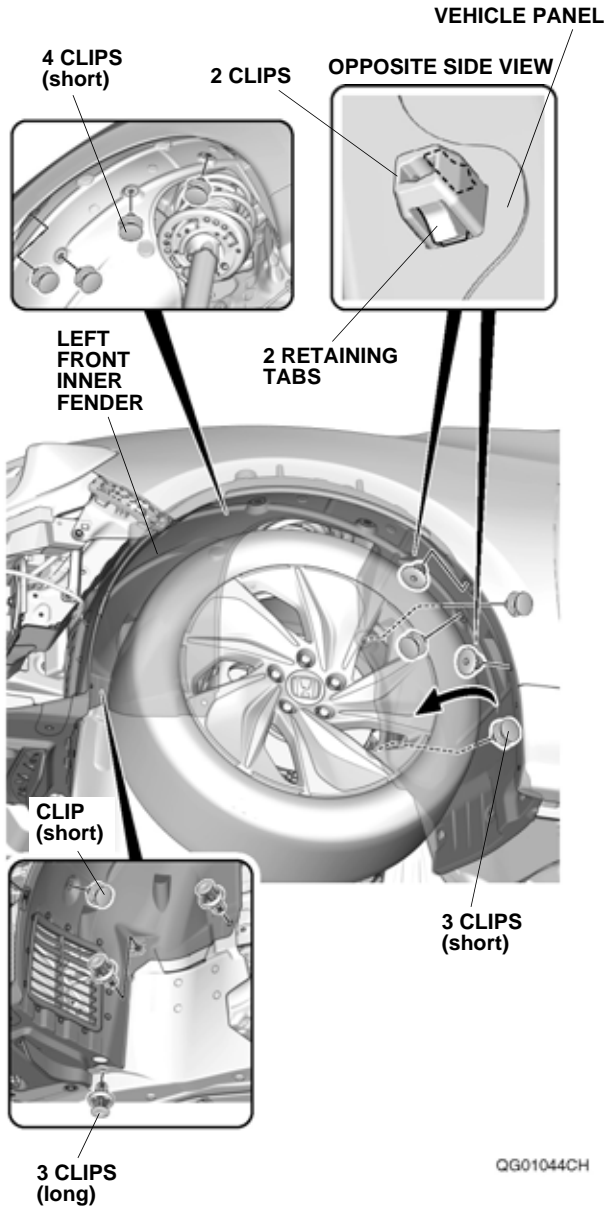

If the vehicle is equipped with the welcome lights, go to step 30; otherwise, continue with step 25.

## Without Welcome Lights

25. Pull back the insulator as shown.

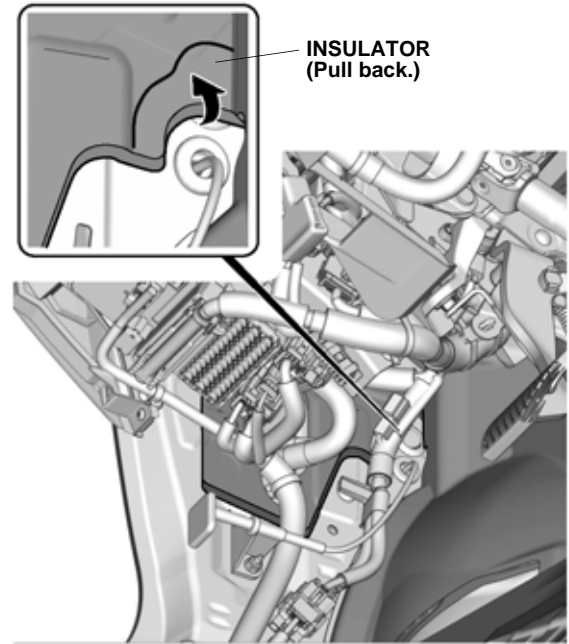

26. Remove the vehicle grommet as shown.

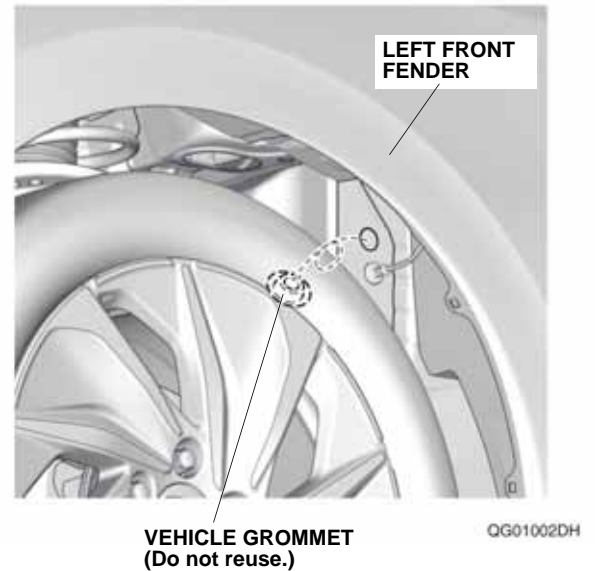

27. Route the subharness through the vehicle panel hole as shown.

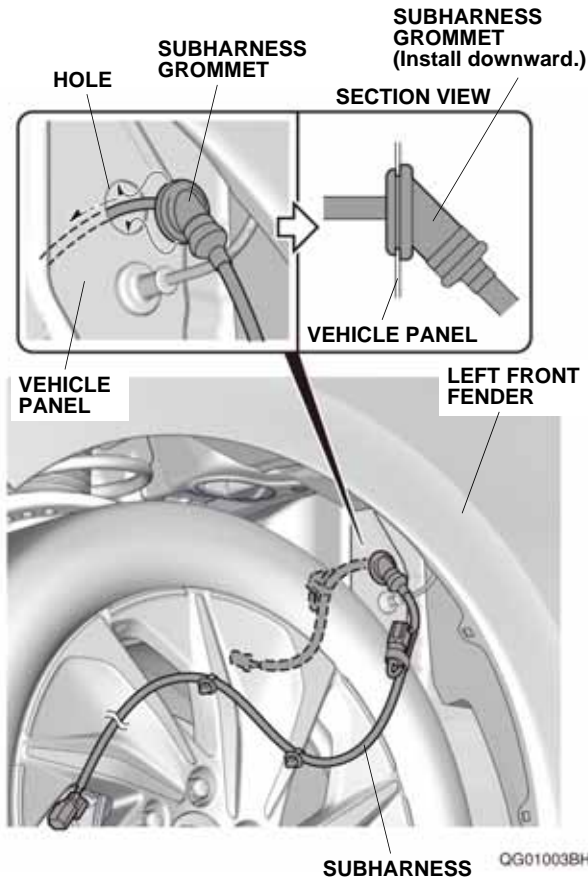

28. Secure the subharness grommet to the vehicle panel hole.

**NOTE:**

- While holding the grommet, carefully insert it into the vehicle panel hole and make sure it is seated properly.
- Do not pull on the socket or harness when installing the grommet.

29. Go to step 35.

## With Welcome Lights

30. Remove the welcome light harness, then unplug the welcome light harness 6-pin connectors as shown.

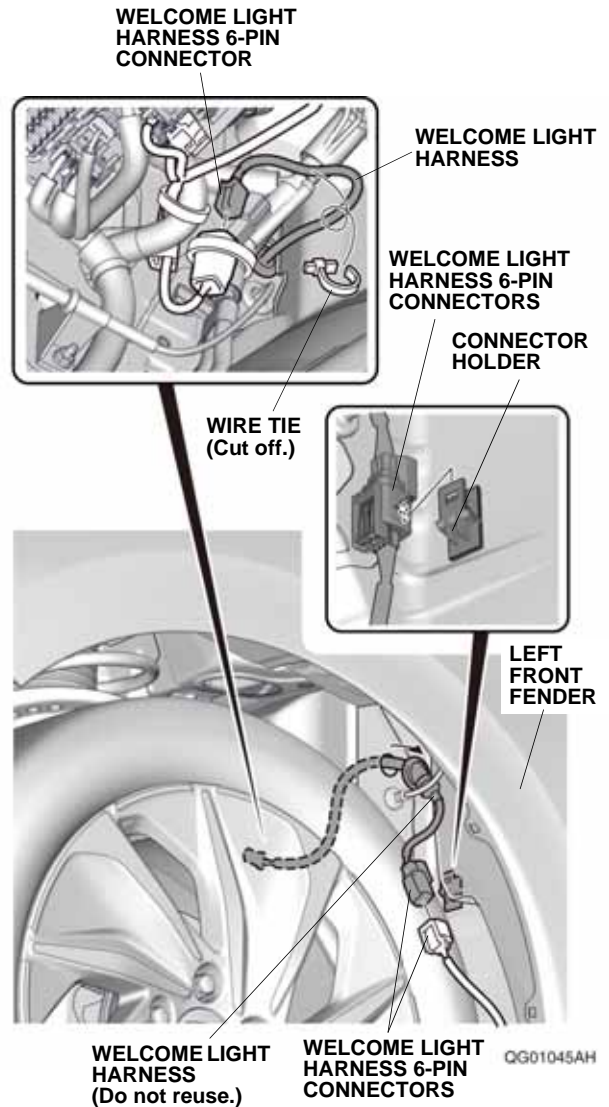

**WELCOME LIGHT HARNESS (Do not reuse.)**

**WELCOME LIGHT HARNESS 6-PIN CONNECTORS**

QG01045AH

31. Route the subharness through the vehicle panel hole as shown.

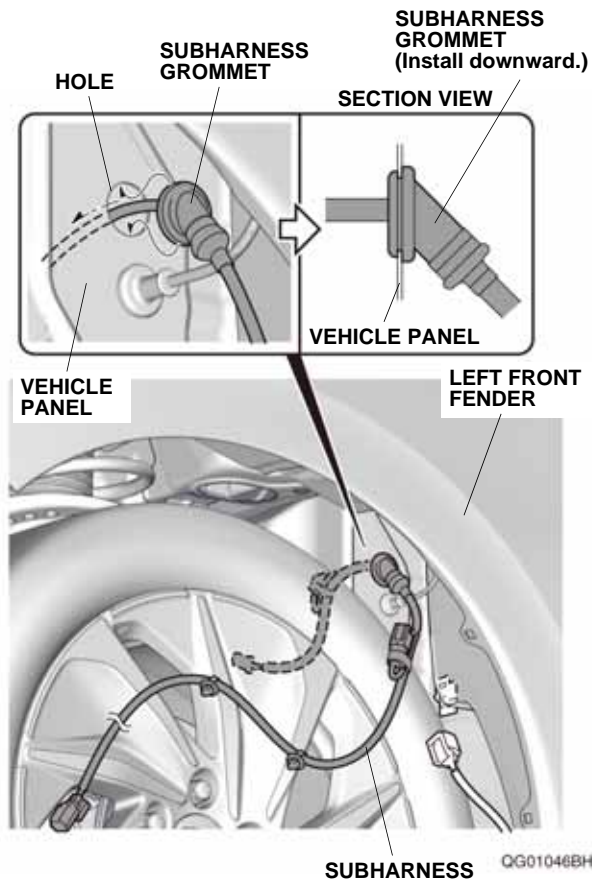

32. Secure the subharness grommet to the vehicle panel hole.

**NOTE:**

- While holding the grommet, carefully insert it into the vehicle panel hole and make sure it is seated properly.
- Do not pull on the socket or harness when installing the grommet.

33. Remove the tape from the subharness, and plug the subharness 6-pin connector into the welcome light harness 6-pin connector as shown.

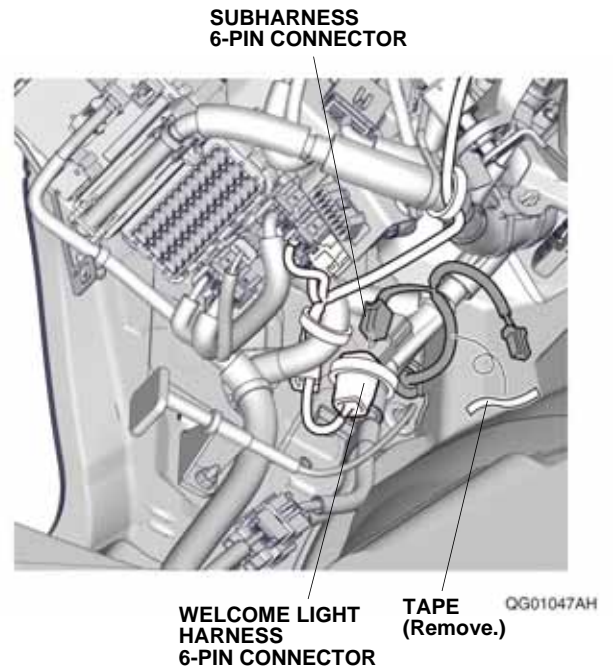

34. Remove the tape from the subharness. Remove the dummy connector from the subharness 6-pin connector, and plug it into the welcome light harness 6-pin connector. Secure the 6-pin connectors to the connector holder.

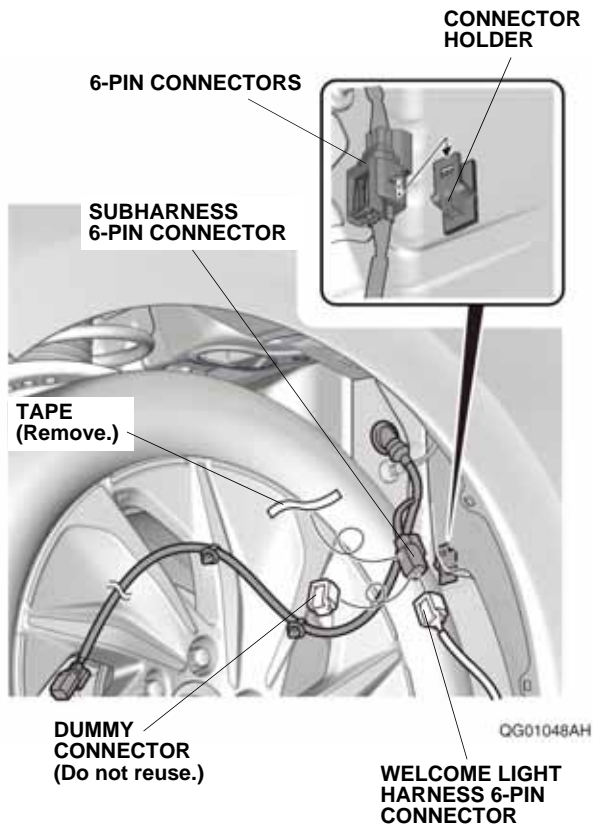

35. Route the subharness as shown.

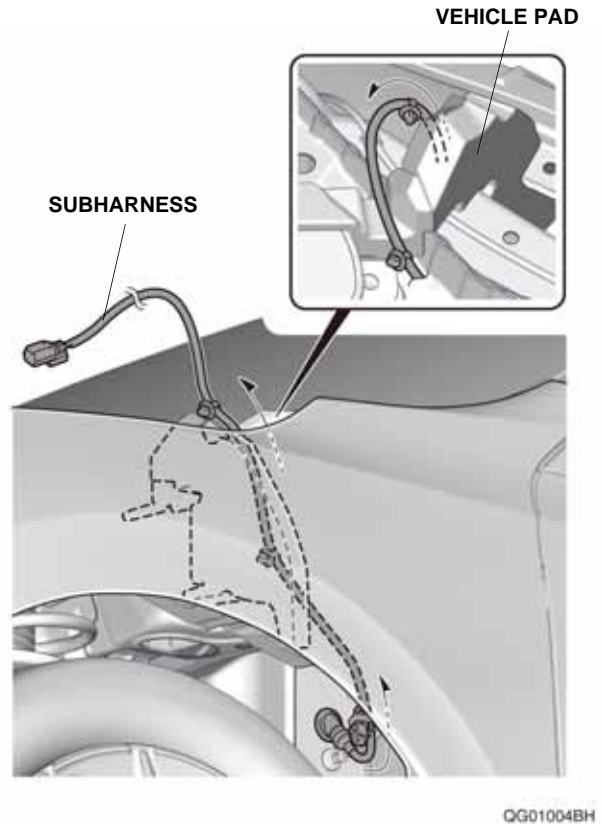



36. Release the vehicle pad, then route the subharness as shown.

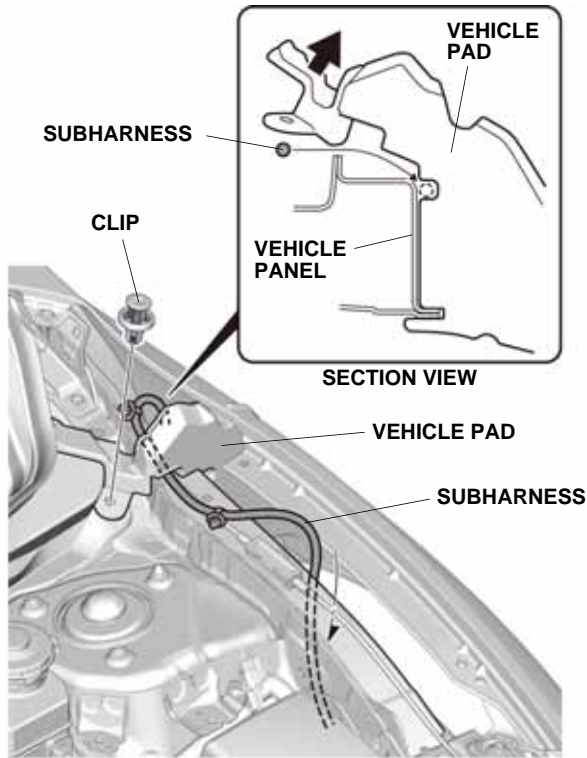

37. Install the vehicle pad.  
38. Secure the subharness to the vehicle panel with the two clips on the subharness.

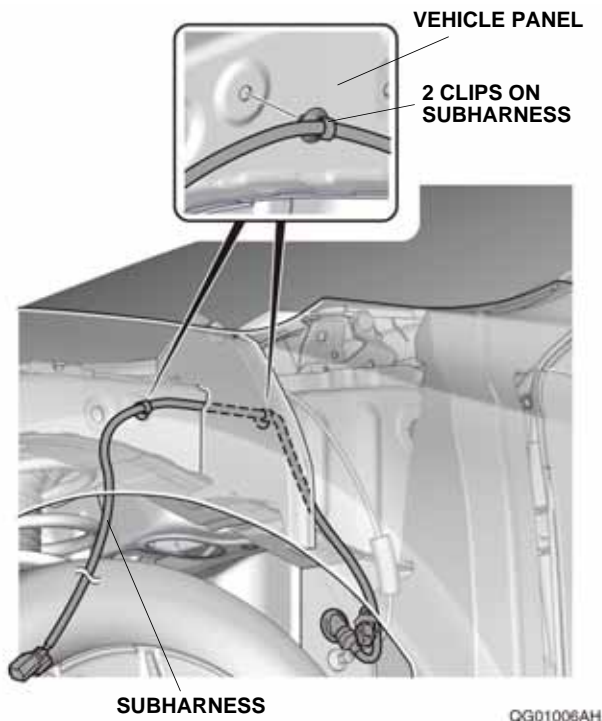

39. Route the subharness as shown.

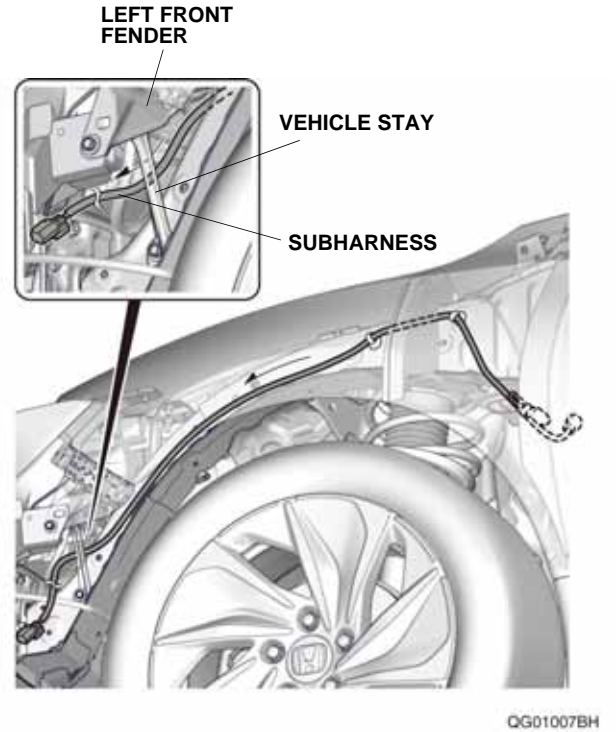

40. Using isopropyl alcohol on a shop towel, thoroughly clean the front bumper beam where the connector holder will attach.

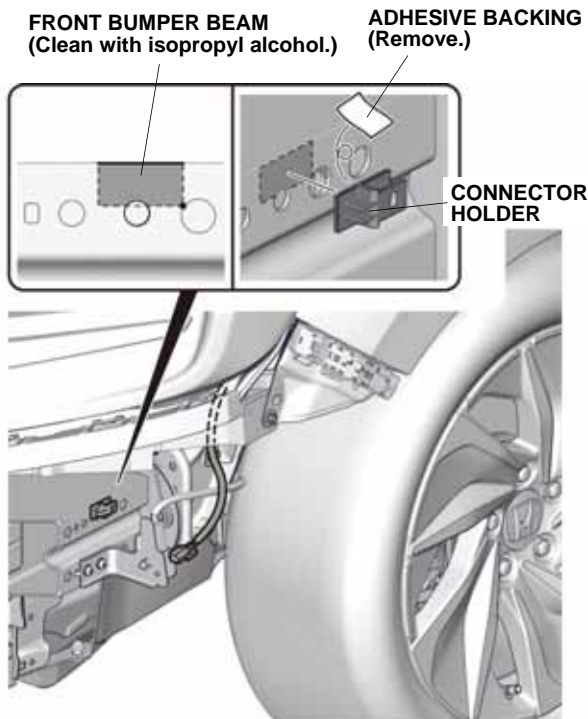

41. Attach the connector holder to the front bumper beam.  
NOTE: Make sure to install the connector holder in the correct direction.

42. Secure the subharness 4-pin connector to the connector holder.

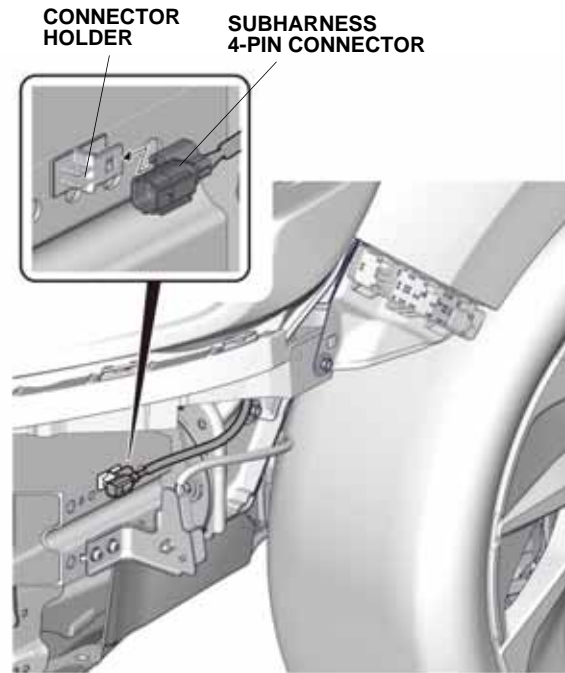

43. Secure the subharness to the vehicle harness and the vehicle panel with two wire ties as shown.

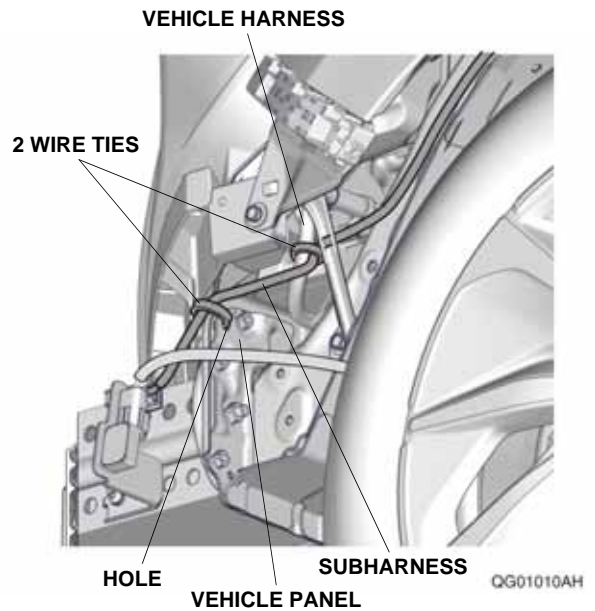

44. Using isopropyl alcohol on a shop towel, thoroughly clean the vehicle panel where the aluminum tape will attach.

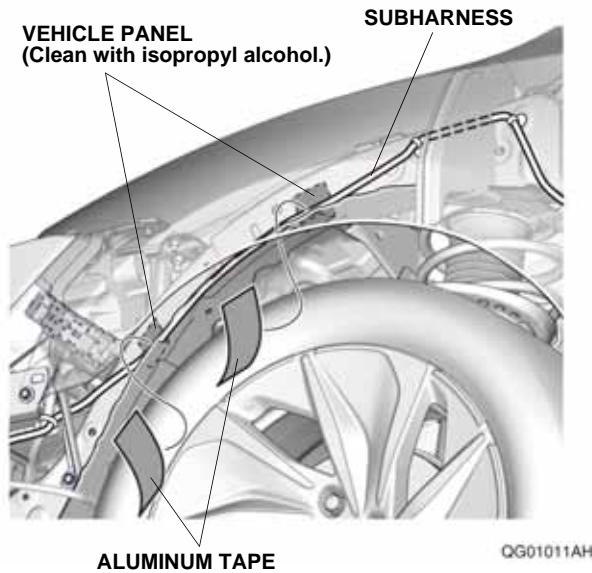

45. Secure the subharness to the vehicle panel with two pieces of aluminum tape as shown.
46. Using isopropyl alcohol on a shop towel, thoroughly clean the parking sensor harness fuse case where the fuse label will attach.

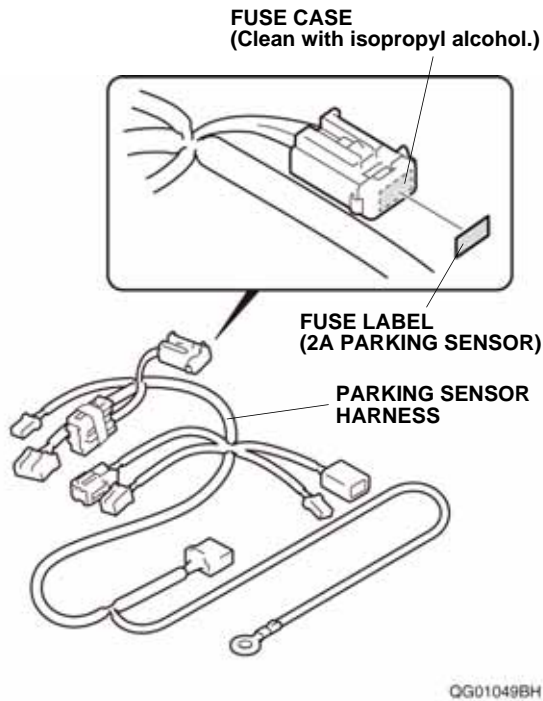

47. Apply the fuse label (2A PARKING SENSOR) to the parking sensor harness fuse case.

48. Release the fuse box.

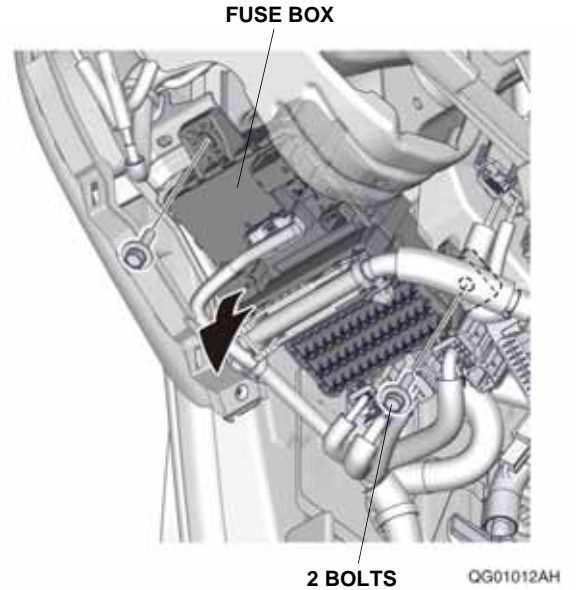

49. Route the parking sensor harness. Plug the subharness 4-pin connector into the parking sensor harness 4-pin connector.

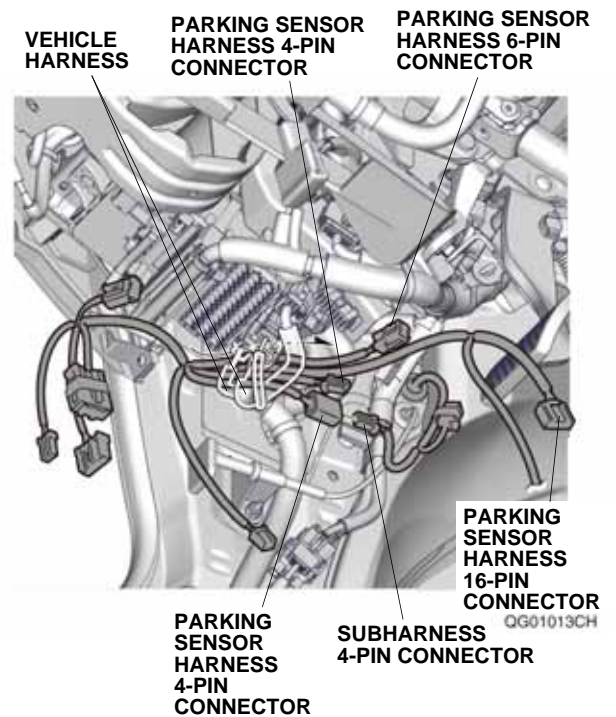

50. Install the control unit bracket to the control unit.  
**NOTE:** Make sure to install the control unit bracket in the correct direction.

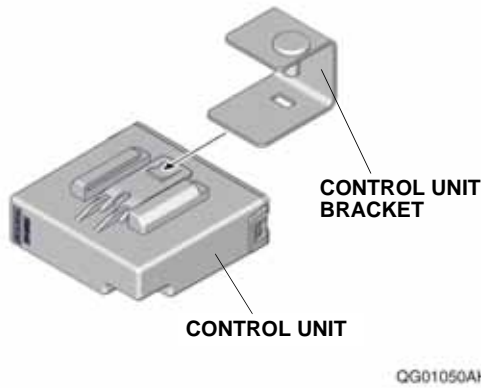

51. If equipped the vehicle unit, unplug the vehicle 32-pin connector, then release the vehicle clip as shown. Secure the control unit bracket to the vehicle frame with one nut as shown.

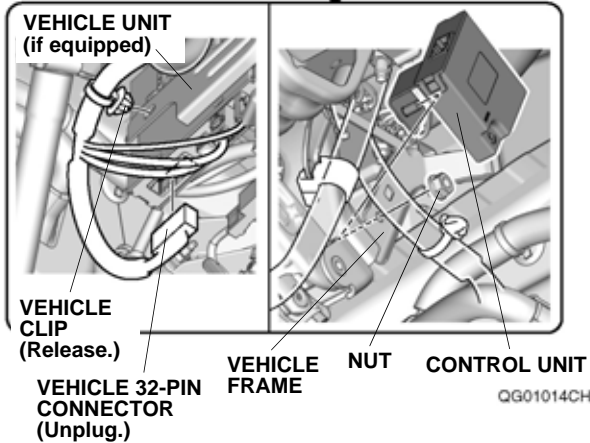
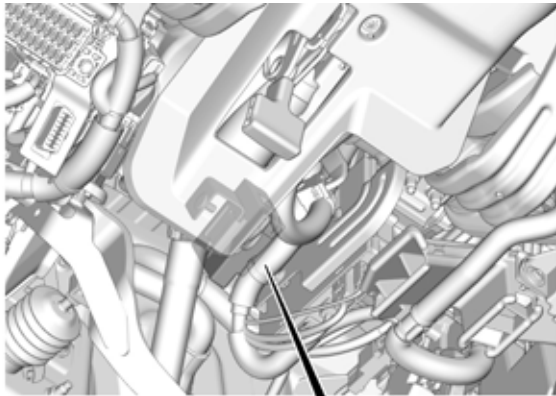

52. If equipped the vehicle unit, plug the vehicle 32-pin connector into the vehicle unit, then attach the vehicle clip.

53. Route the parking sensor harness as shown.

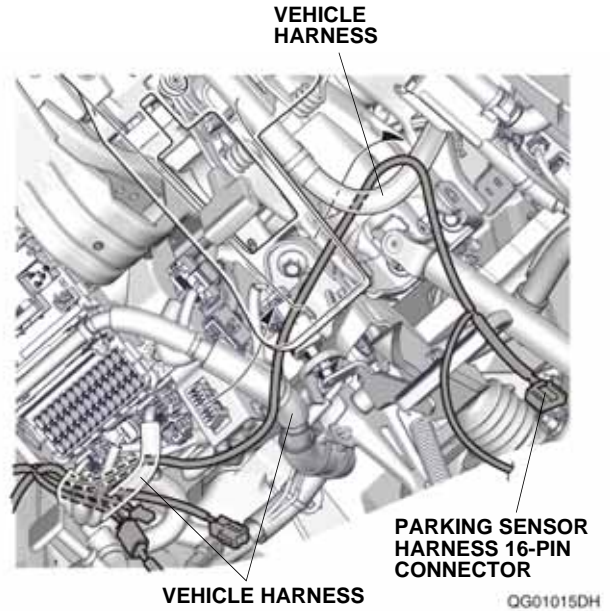

54. Plug the parking sensor harness 16-pin connector into the control unit.

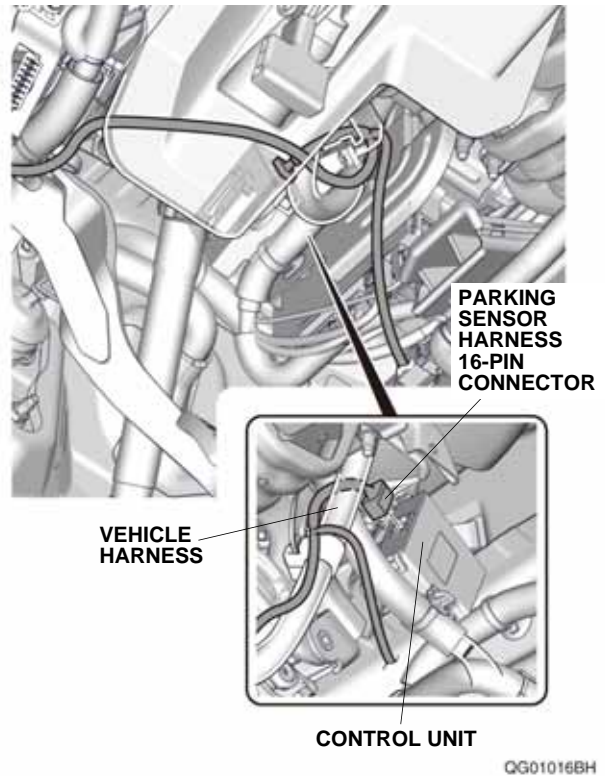

55. Unplug the vehicle 20-pin connector from the fuse box, and plug it into the parking sensor harness 20-pin connector as shown. Then, plug the parking sensor harness 20-pin connector into the fuse box.

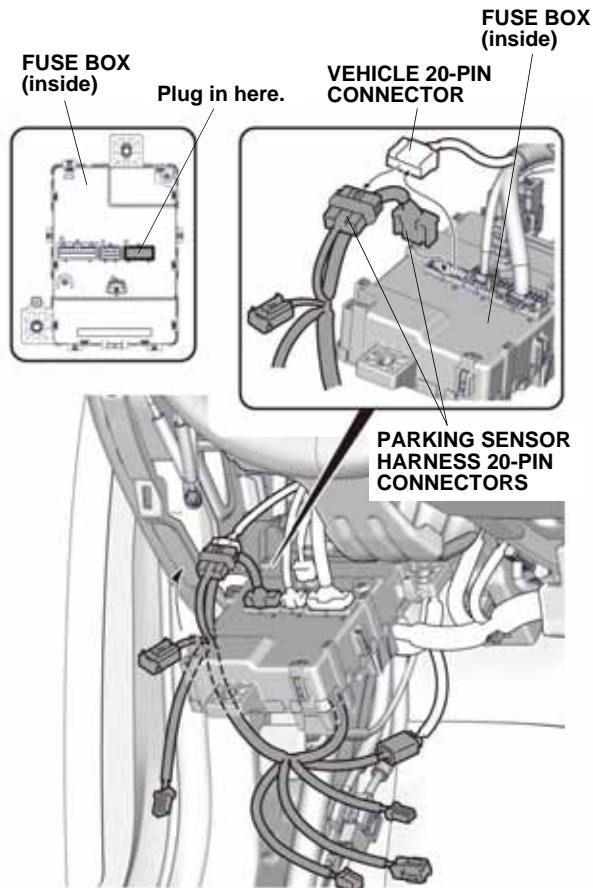

QG01017AH

56. Install the fuse box.

57. Line up the branch of the parking sensor harness with the vehicle clip, and secure the parking sensor harness and fuse case to the vehicle harness with one wire tie as shown.

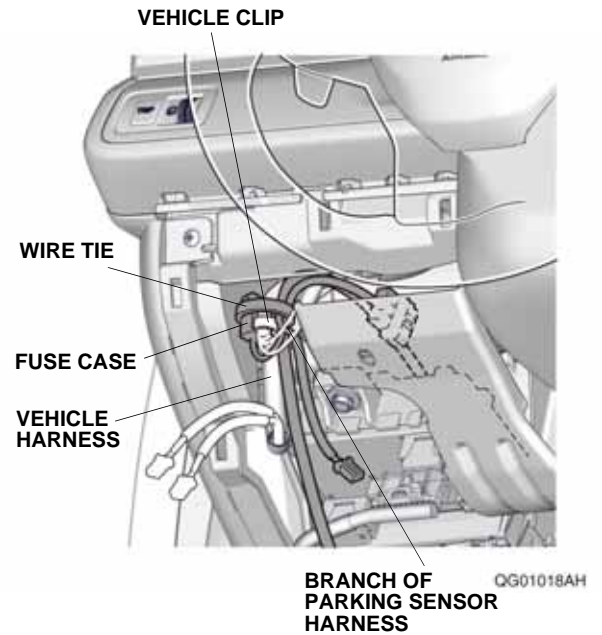

If the vehicle is equipped another accessory harness 6-pin connector, go to step 60; otherwise, continue with step 58.

58. Plug the parking sensor harness 6-pin connector into the vehicle 6-pin connector.

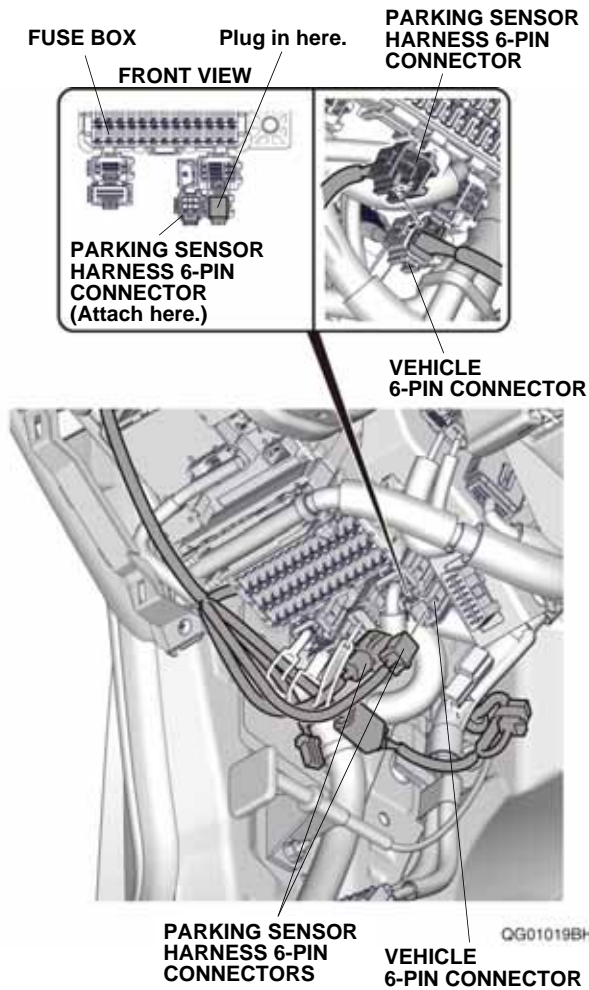

59. Attach the parking sensor harness 6-pin connector to the vehicle 6-pin connector. Go to step 62.

## With Another Accessory Harness 6-Pin Connector

60. If the other accessory harness 6-pin connector is plugged into the vehicle 6-pin connector, unplug it and plug it into the parking sensor harness 6-pin connector. Then, plug the parking sensor harness 6-pin connector into the vehicle 6-pin connector.

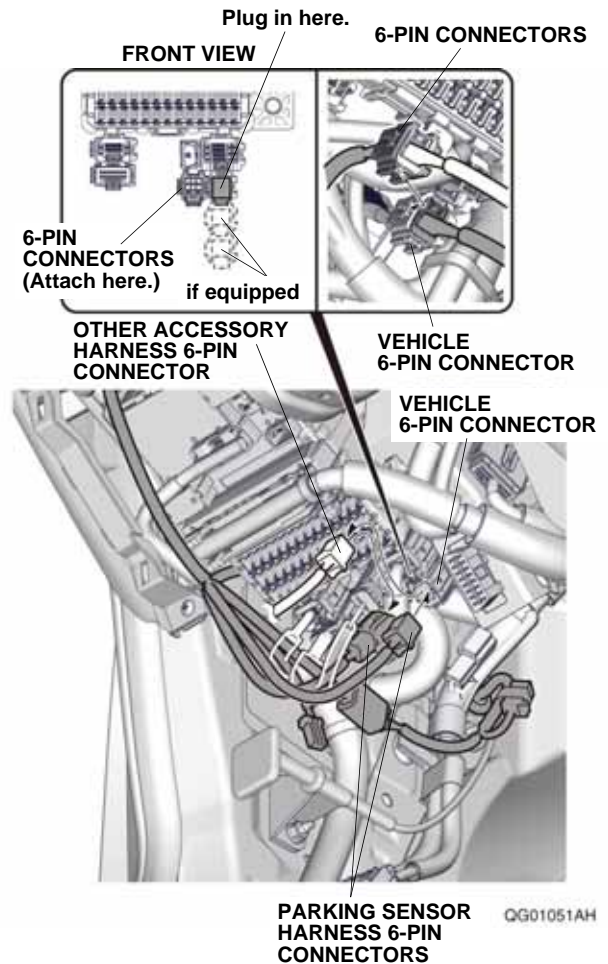

61. Attach the 6-pin connectors to the vehicle 6-pin connector.

62. Secure the parking sensor harness to the vehicle harness with one wire tie.

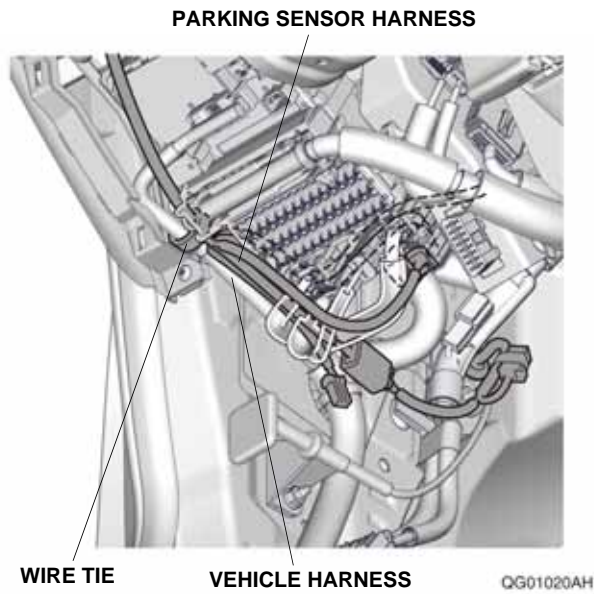

63. Secure the parking sensor harness to the vehicle harness with one wire tie.

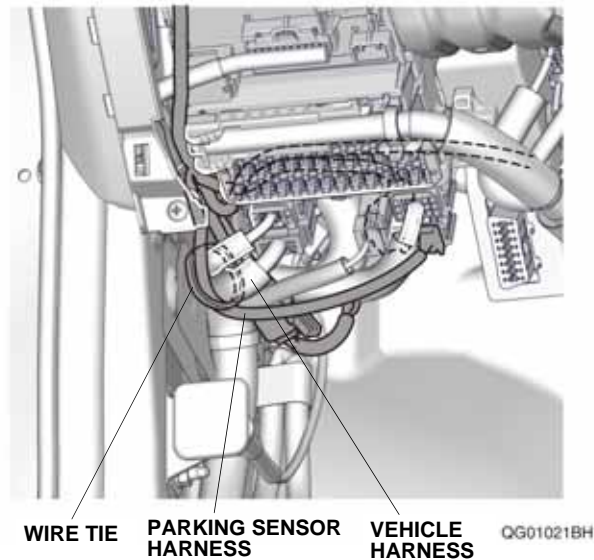

64. Secure the parking sensor harness to the vehicle harness with two wire ties.

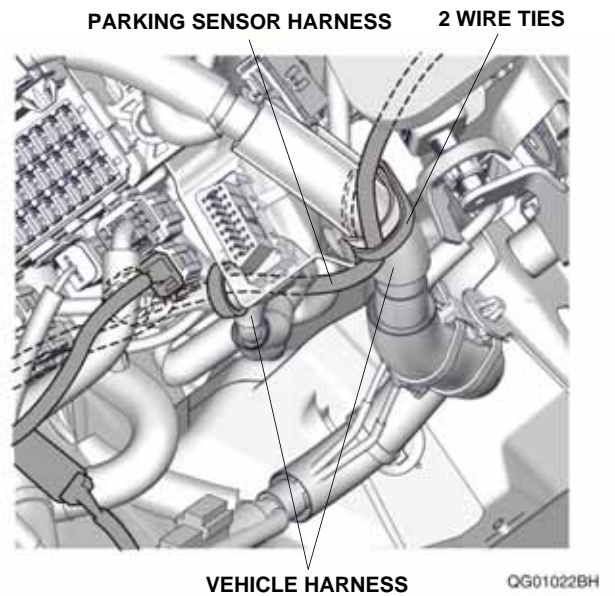

65. Secure the parking sensor harness to the vehicle harness and vehicle bracket with two wire ties as shown.

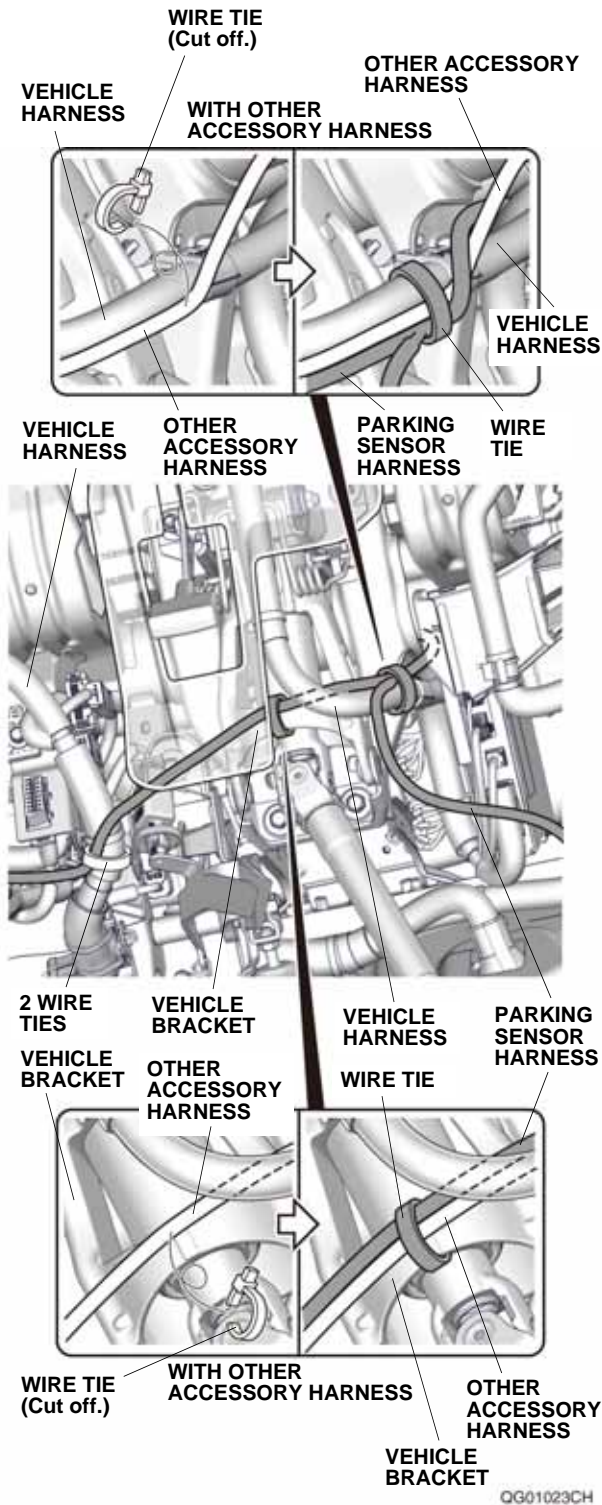

66. Secure the parking sensor harness to the vehicle duct with two wire ties.

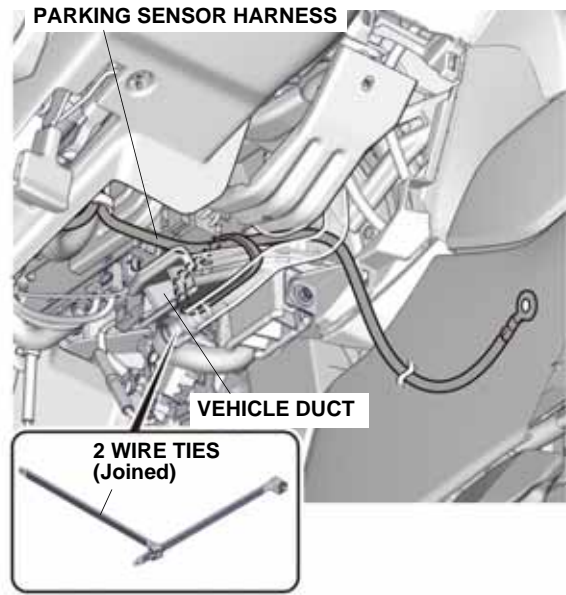

QG01024BH

67. Route the parking sensor harness as shown.

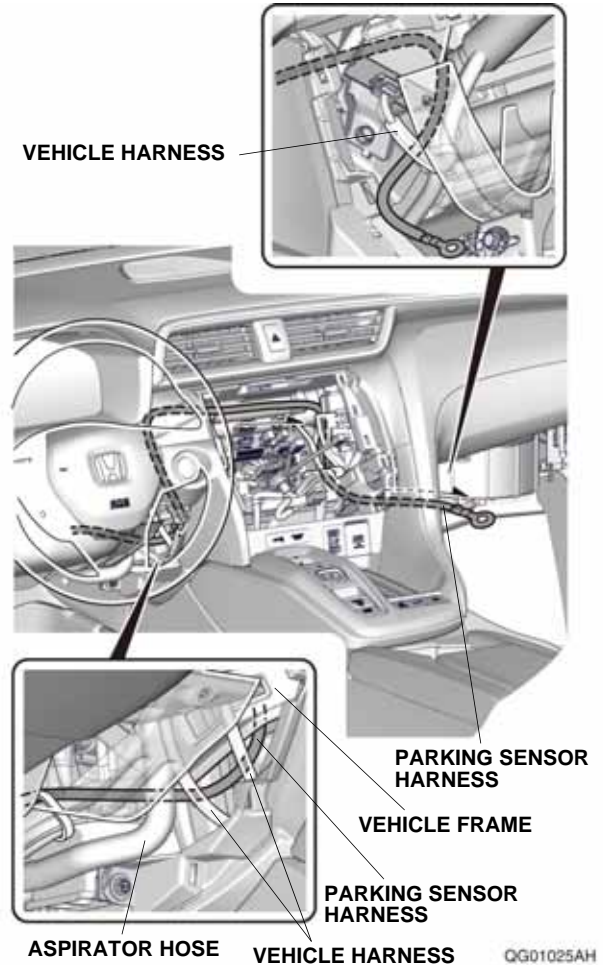



68. Remove the vehicle ground bolt. Secure the parking sensor harness ground terminal and the vehicle ground terminal with the vehicle ground bolt just removed.  
 NOTE: Do not put the ground terminal callings on top of one another.

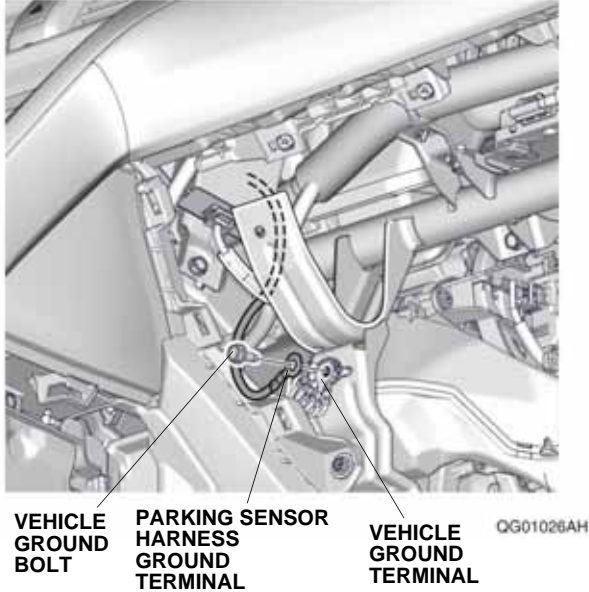

69. Secure the parking sensor harness to the vehicle harness with one wire tie.

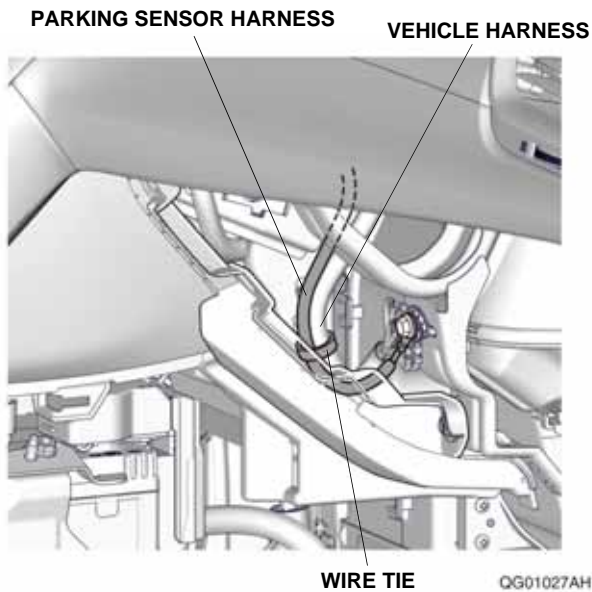

70. Secure the parking sensor harness to the vehicle harness with one wire tie.

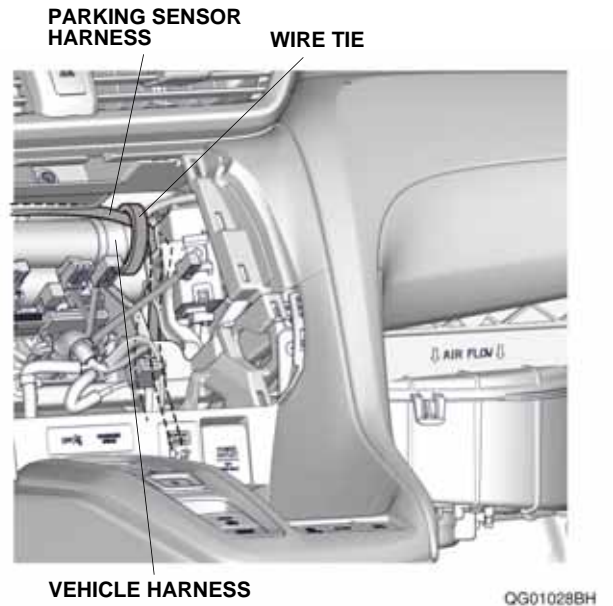

71. Secure the parking sensor harness to the vehicle harness and vehicle harness cover with two wire ties.

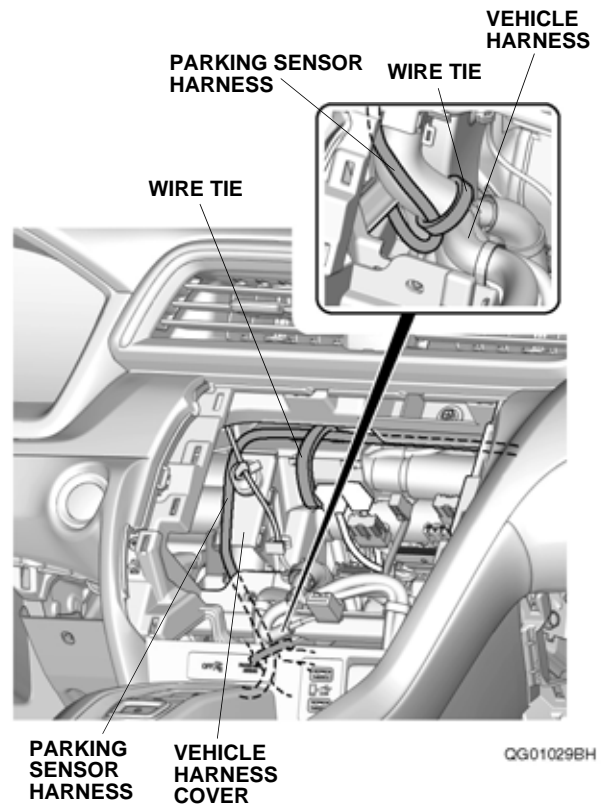

72. Plug the parking sensor harness 4-pin connector into the floor harness 4-pin connector.

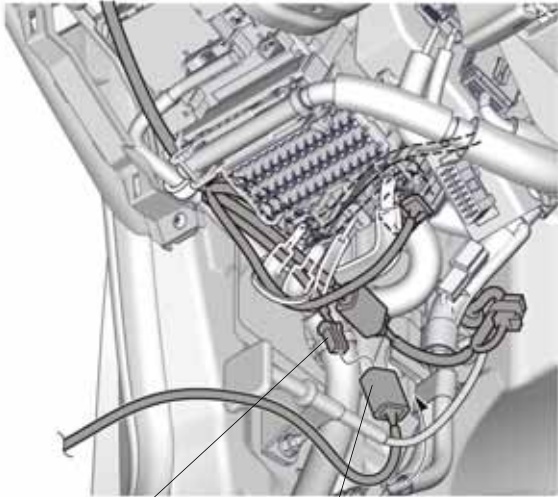

PARKING SENSOR HARNESS 4-PIN CONNECTOR  
 FLOOR HARNESS 4-PIN CONNECTOR QG01030BH

73. Secure the 4-pin connectors to the vehicle harness with one wire tie as shown.

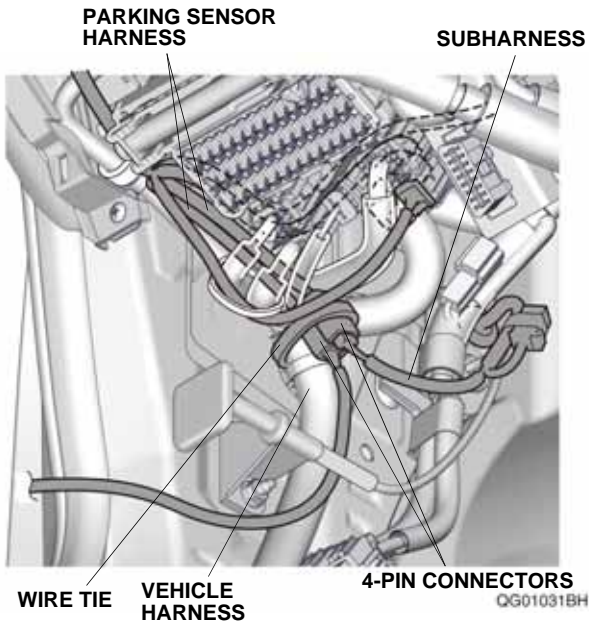

PARKING SENSOR HARNESS  
 SUBHARNESS  
 WIRE TIE  
 VEHICLE HARNESS  
 4-PIN CONNECTORS QG01031BH

74. Peel back the floor carpet. Route the floor harness as shown.

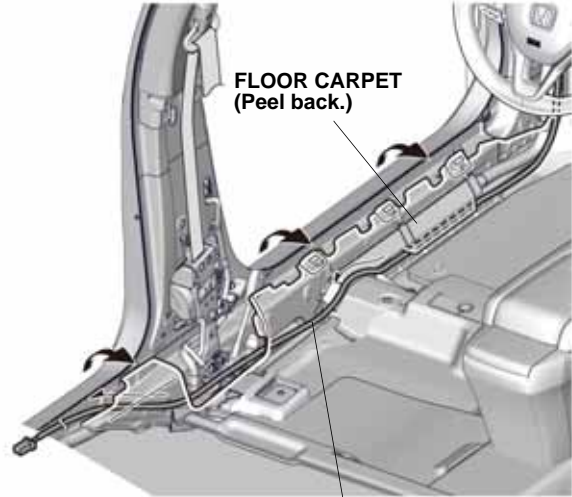

FLOOR CARPET (Peel back.)  
 FLOOR HARNESS QG01032AH

75. Secure the floor harness to the vehicle harness with three wire ties.

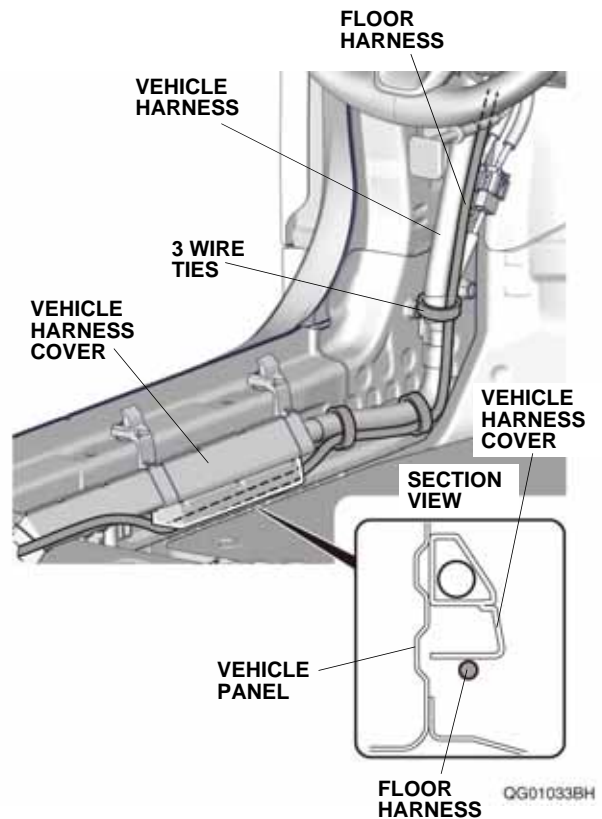

FLOOR HARNESS  
 VEHICLE HARNESS  
 3 WIRE TIES  
 VEHICLE HARNESS COVER  
 SECTION VIEW  
 VEHICLE PANEL  
 FLOOR HARNESS QG01033BH

76. Using isopropyl alcohol on a shop towel, thoroughly clean the vehicle panel and vehicle harness cover where the aluminum tape will attach.

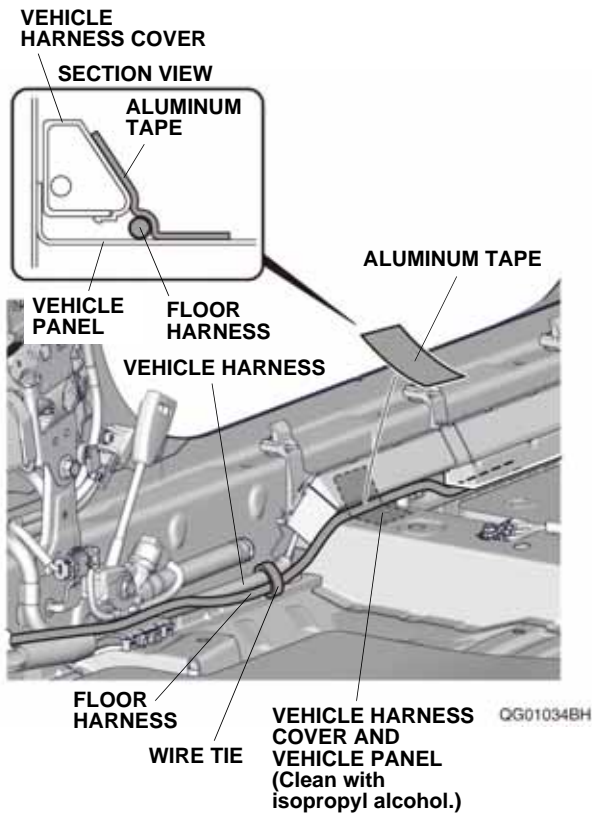

77. Secure the floor harness with one piece of aluminum tape as shown.
78. Secure the floor harness to the vehicle harness with one wire tie.

79. Line up the green tape on the floor harness with the vehicle clip, and secure the floor harness to the vehicle harness with one wire tie.

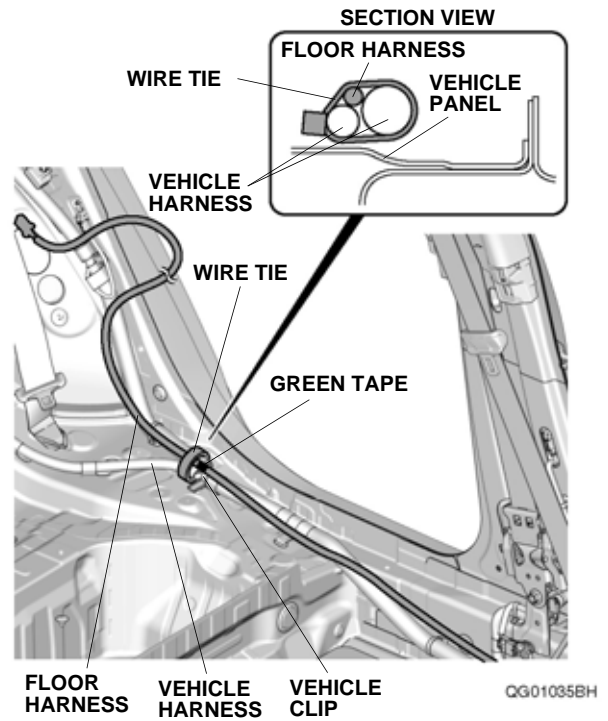

80. Secure the floor harness to the vehicle harness with two wire ties.

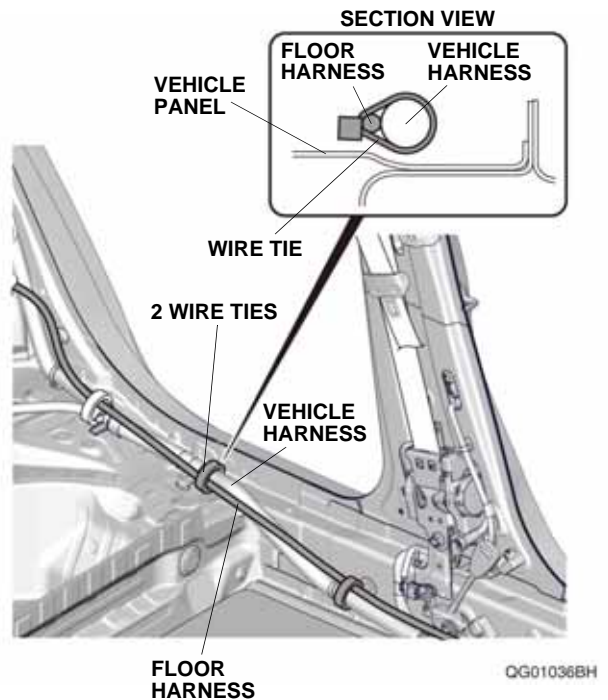

81. Secure the floor harness to the vehicle harness with four wire ties.

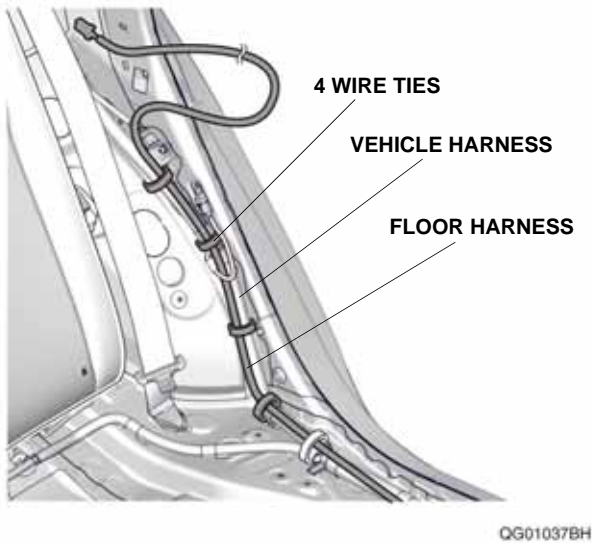

82. Route the floor harness as shown.

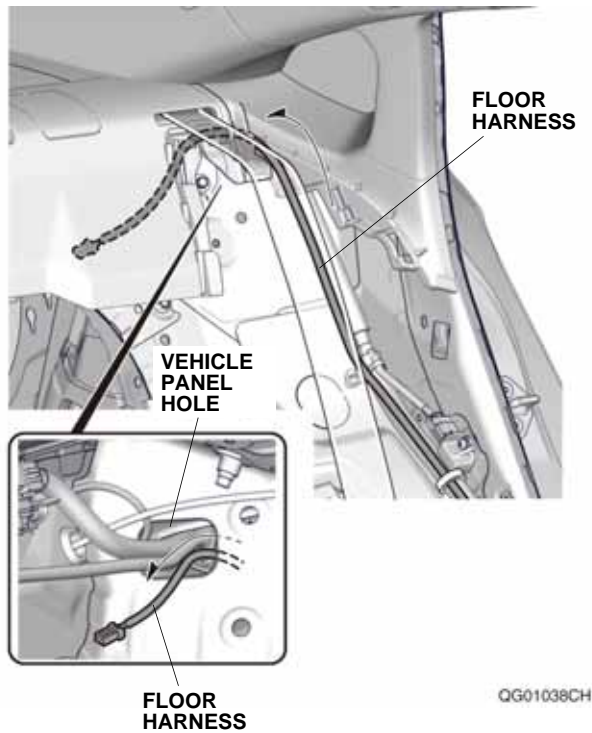

83. Remove the tape to free the vehicle 4-pin connector, and plug the floor harness 4-pin connector into it.

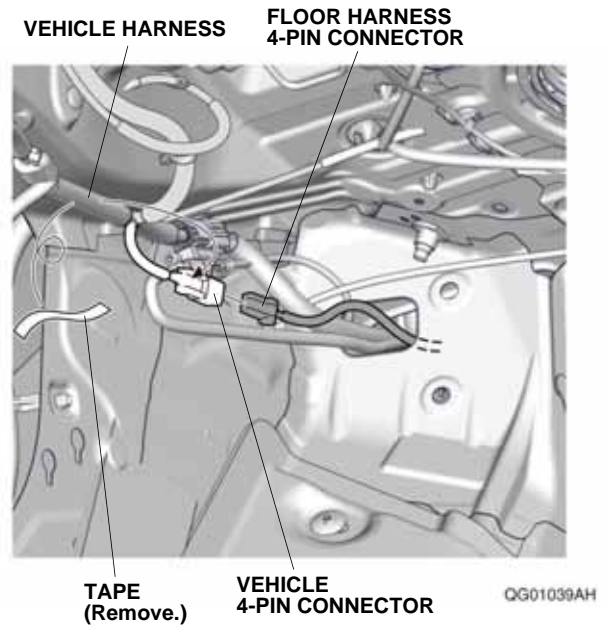

84. Secure the floor harness and 4-pin connectors to the vehicle harness with three wire ties.

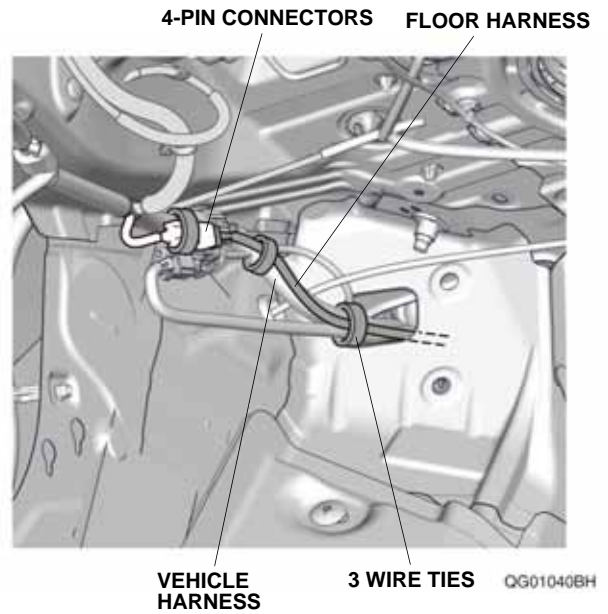

85. Secure the floor harness to the vehicle harness with three wire ties.

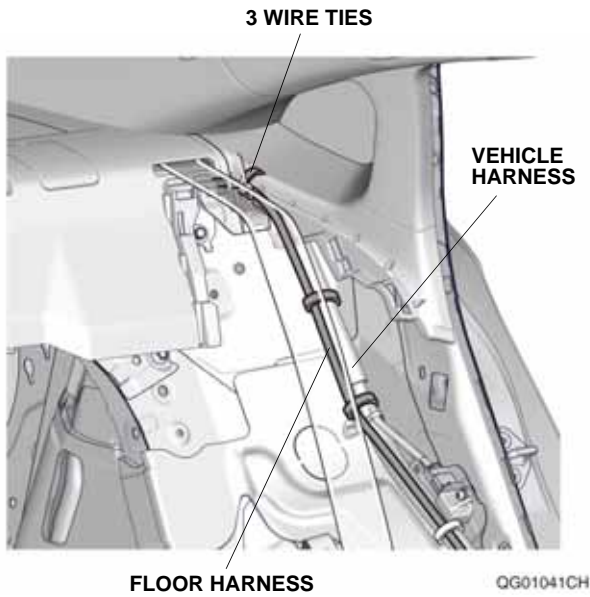

86. Remove the lid from the driver's dashboard lower cover.

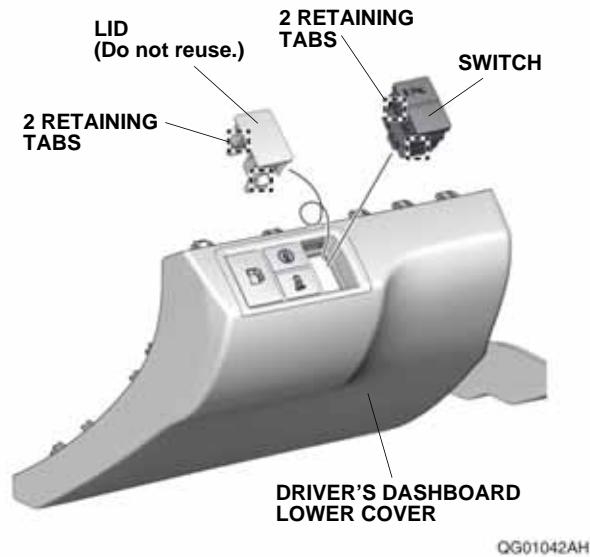

87. Install the switch to the driver's dashboard lower cover.

88. Install the driver's dashboard side lid. Plug the parking sensor harness 5-pin connector into the switch. Install the driver's dashboard lower cover.

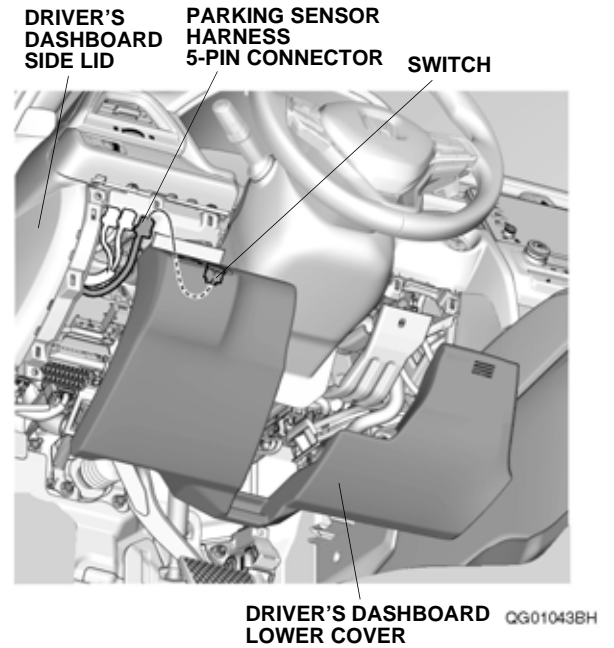

89. Route the front bumper harness as shown.

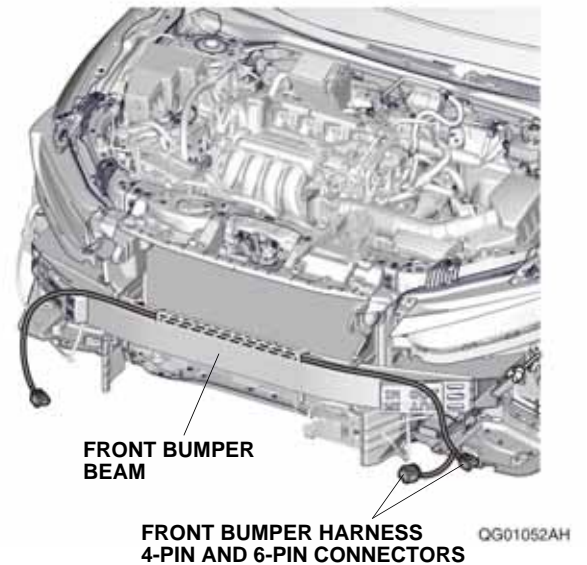

90. Plug the front bumper harness 4-pin connector into the subharness 4-pin connector.

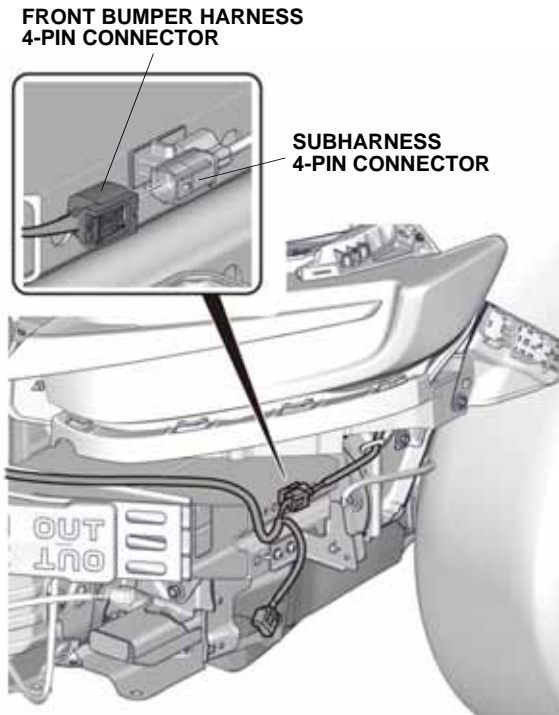

91. Secure the front bumper harness to the front bumper beam with one wire tie at the green tape on the front bumper harness as shown.

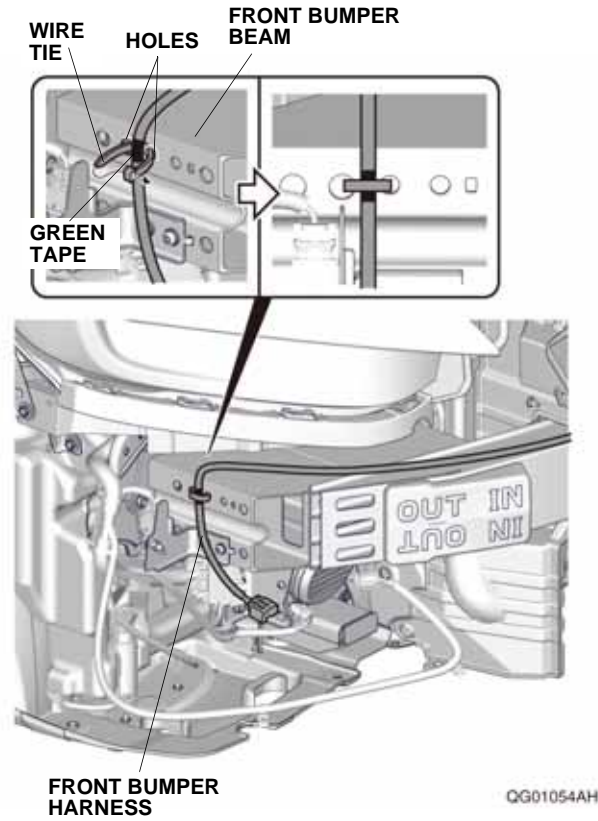

92. Using isopropyl alcohol on a shop towel, thoroughly clean the front bumper beam where the aluminum tape will attach.

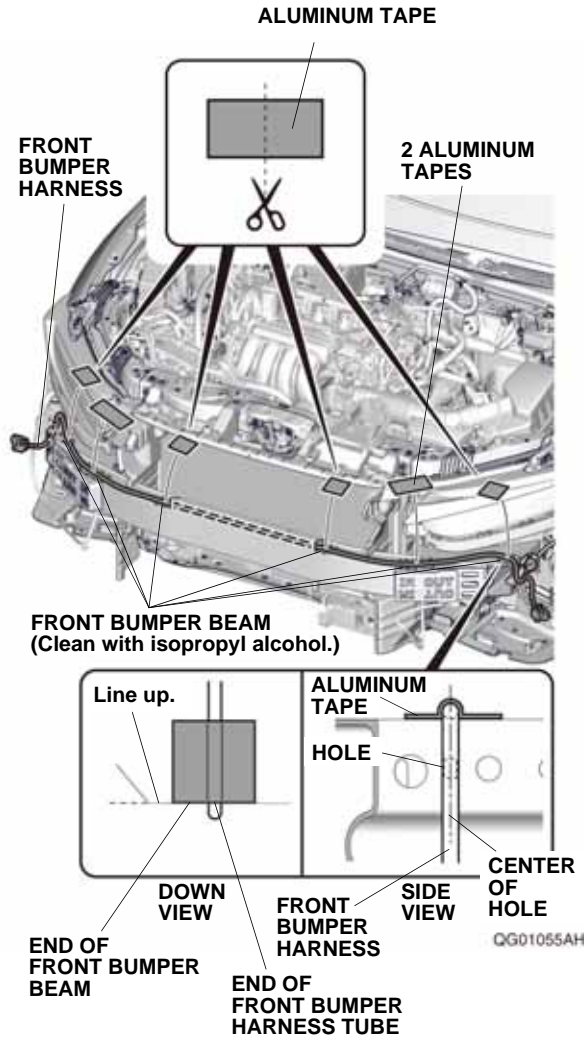

93. Using scissors, cut two pieces of aluminum tape in half, and secure the front bumper harness to the front bumper beam with the four pieces of aluminum tape as shown.
94. Secure the front bumper harness to the front bumper beam with the two pieces of aluminum tape as shown.

95. Mark the inside of the front bumper. Using a pushpin, pierce the front bumper at the center of the two scribe marks.
- NOTE: Pierce the scribe marks perpendicular to the front bumper.

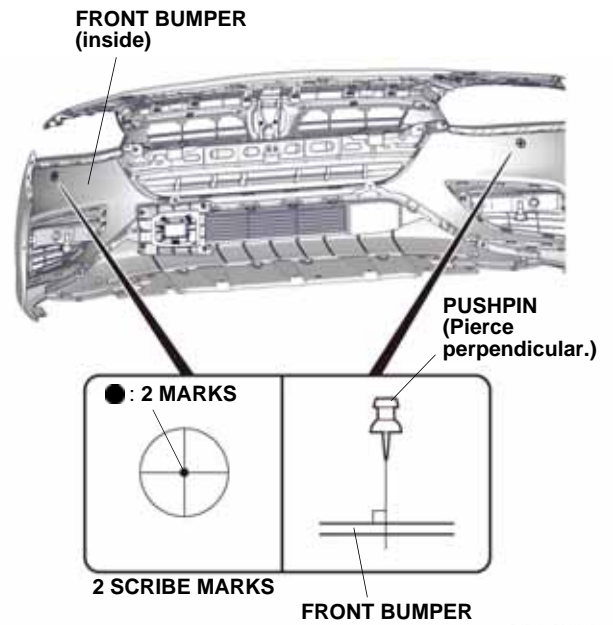

96. Using a felt-tip pen, mark the front bumper as shown.

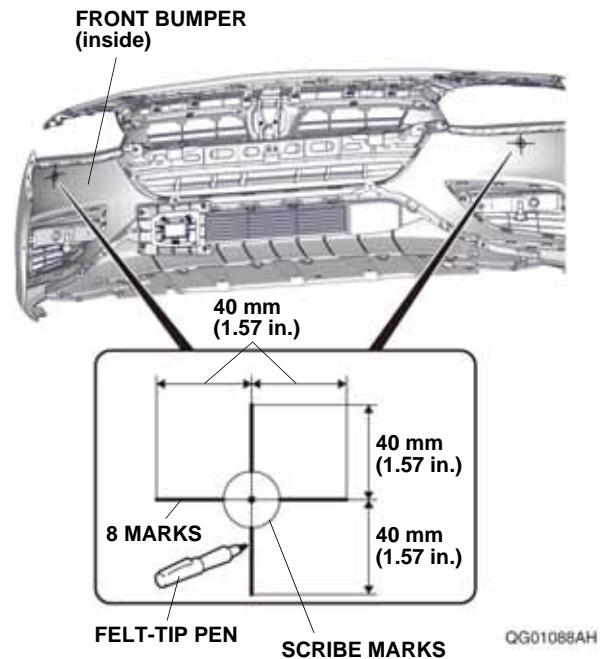

97. While wearing eye protection, drill the two pierced marks to 8.5 mm from the inside of the front bumper. First, drill with a 3 mm drill bit, then follow with a 6 mm drill bit, and finish with an 8.5 mm drill bit.  
NOTE: Make sure to drill perpendicular to the front bumper. Remove any burrs.

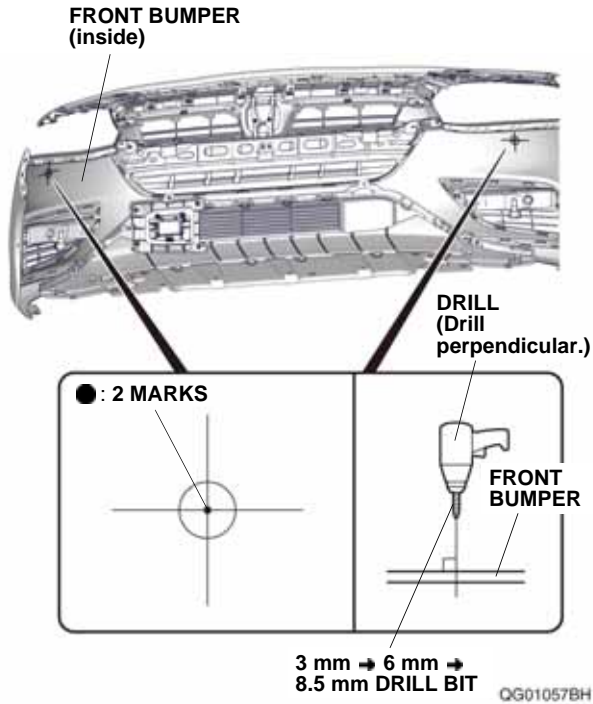

98. Using a 16 mm punch tool, punch out the two front bumper holes as shown.  
NOTE: Make sure to hold the punch perpendicular to the front bumper. Remove any burrs.

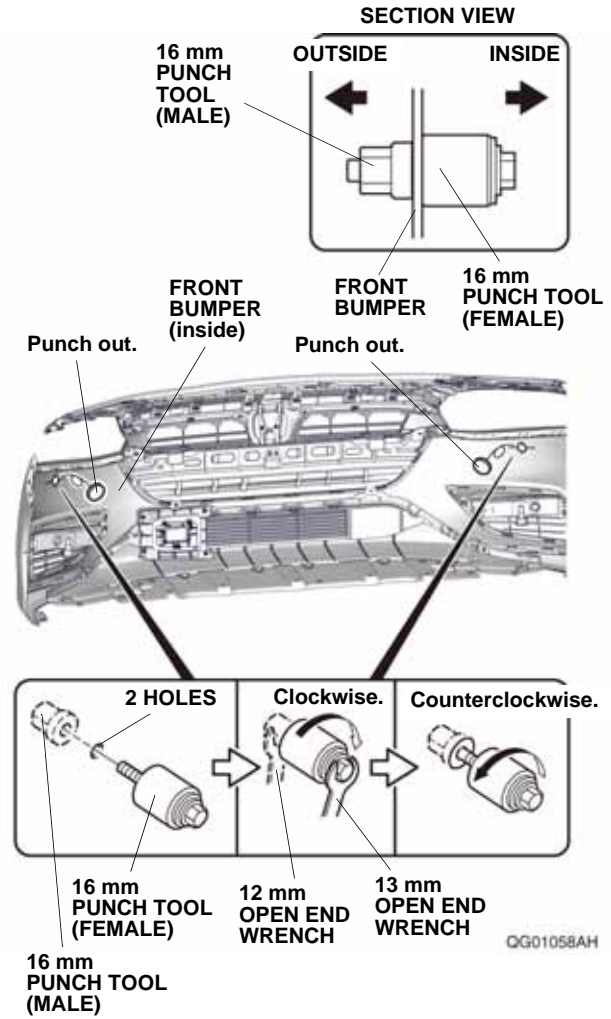



99. Install the two rubber spacers to the two sensors as shown.

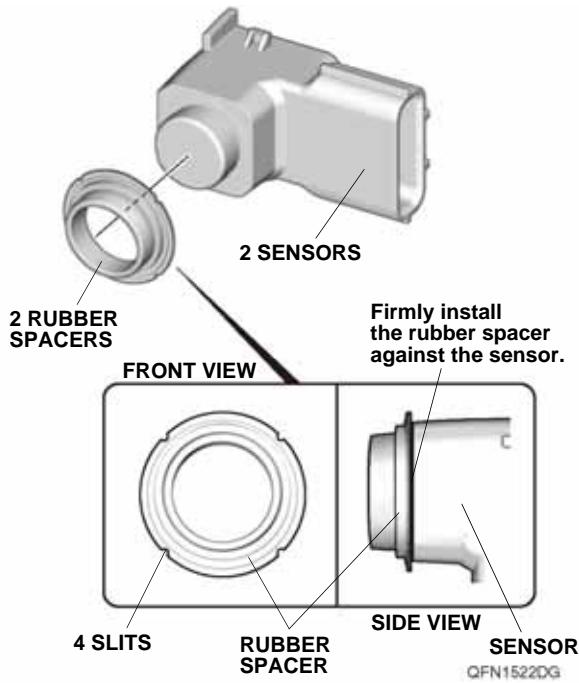

100. Using diagonal cutters, cut the two tabs off the retainers A as shown. Remove any burrs.

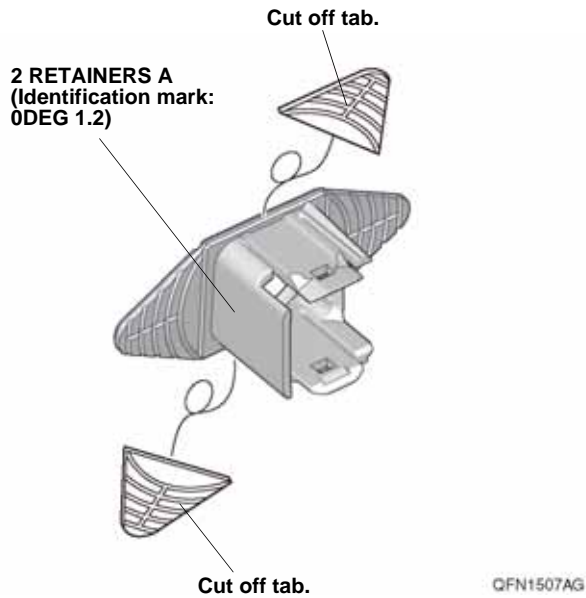

101. Install the two sensors to the two retainers A.

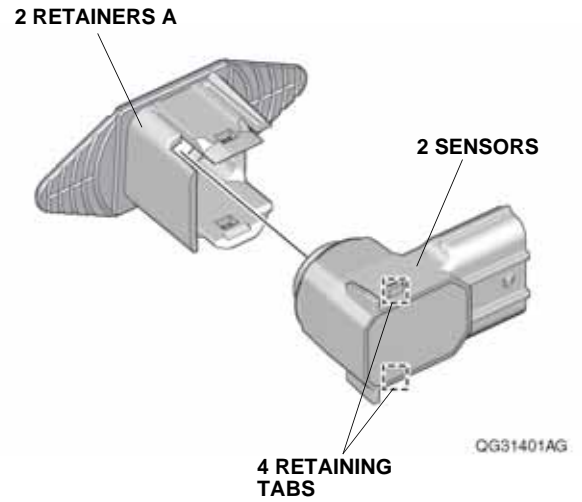

102. Line up the two sensors and two retainers A to the front bumper as shown.

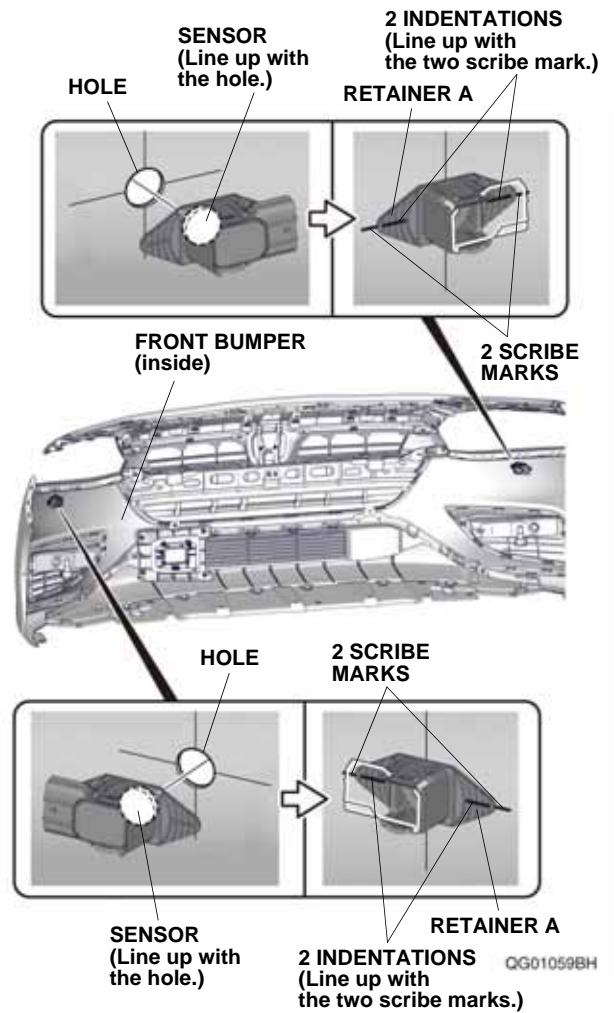

103. Make sure the two sensors are installed properly.

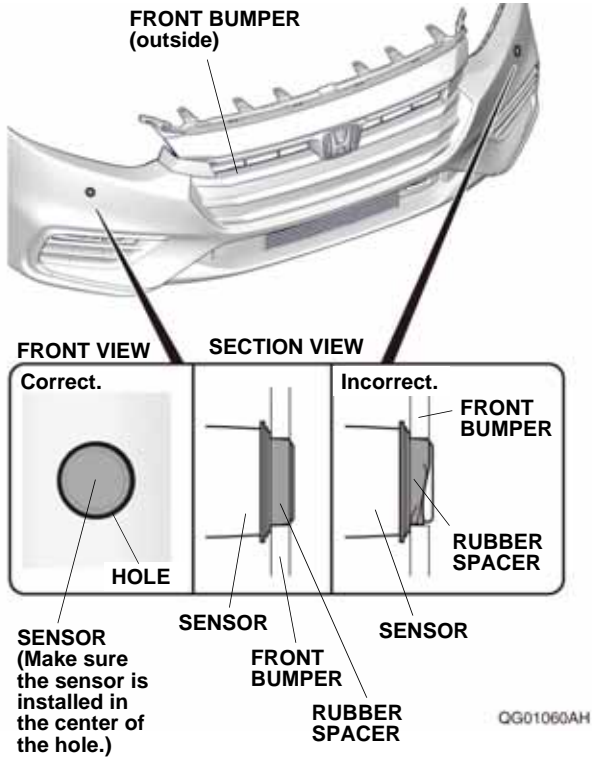

104. Using a felt-tip pen, mark the front bumper as shown.

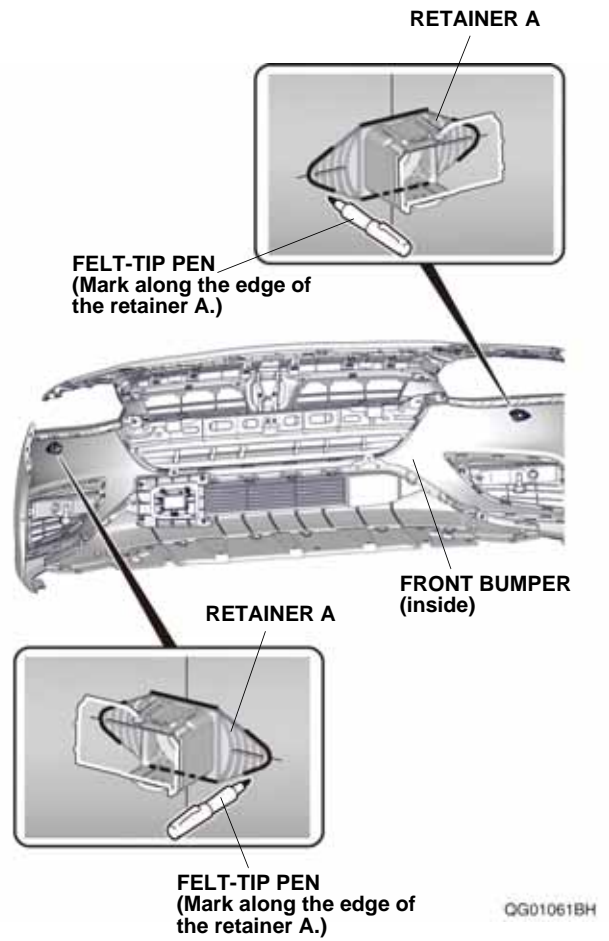

105. Using an alcohol wipe, thoroughly clean the front bumper where retainer A will attach.

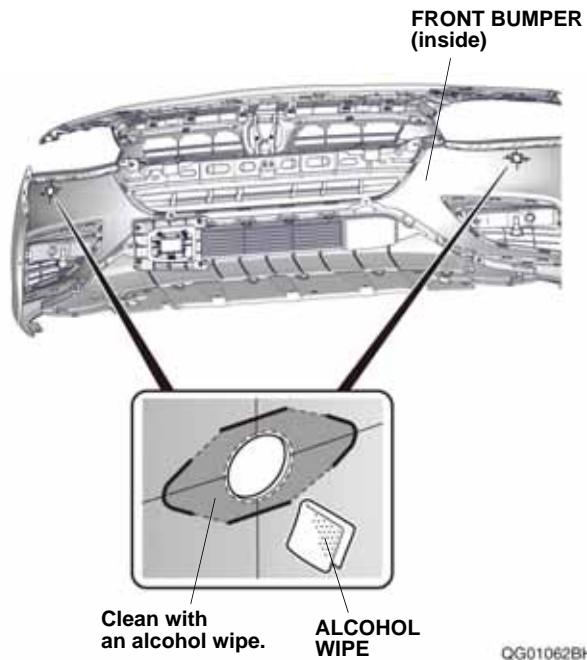

106. Apply the primer to the front bumper.

NOTE:

- Apply the primer evenly.
- Be careful not to apply the primer anywhere except the indicated area.
- Do not apply additional primer.
- Apply the primer, and let it dry for at least 10 minutes.
- Attach the front retainers within 24 hours after applying the primer.
- Do not use an expired primer.

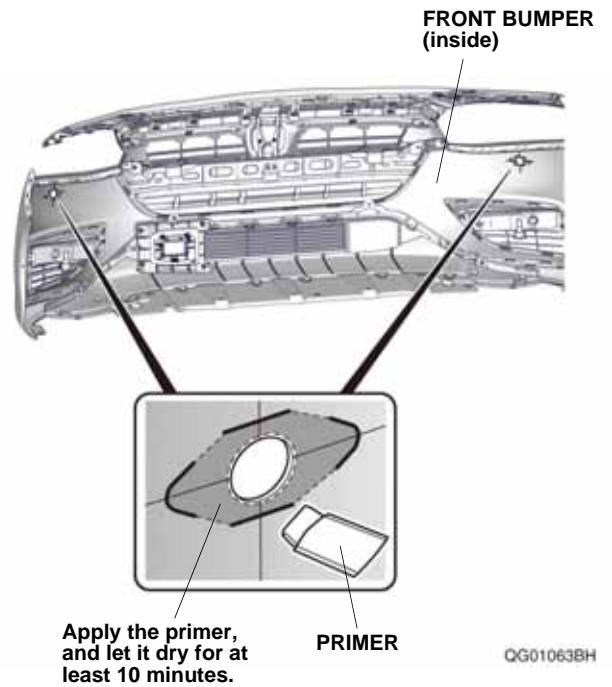

107. Remove the six adhesive backings from the two retainers A, and attach them to the front bumper as shown.

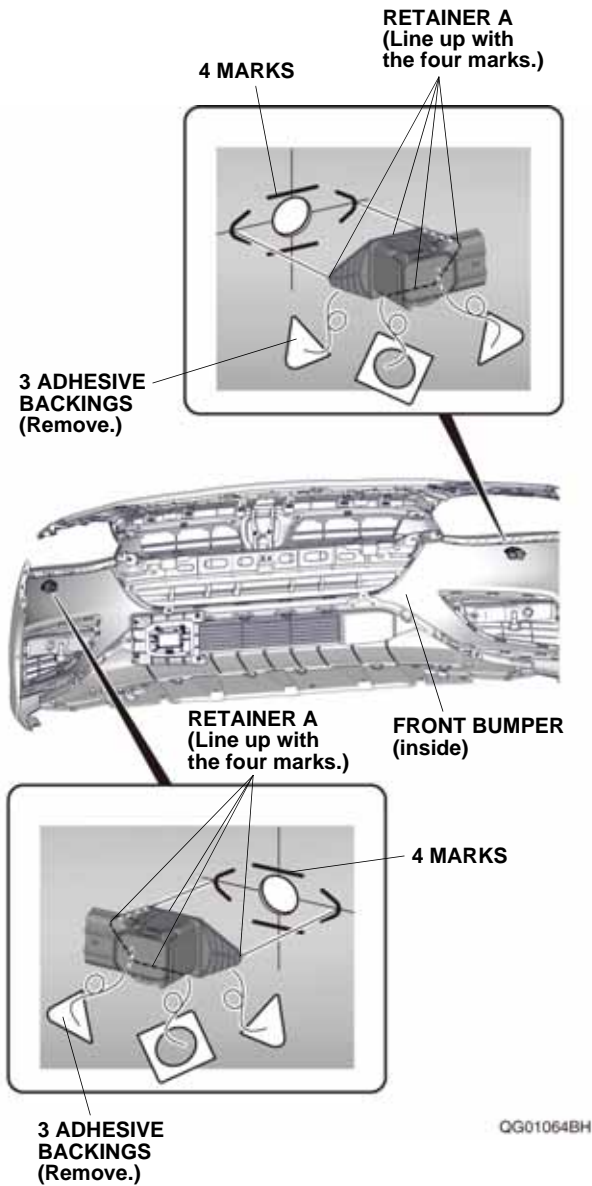

108. Remove the two sensors, and firmly press the two retainers A against the front bumper. Install the two sensors.

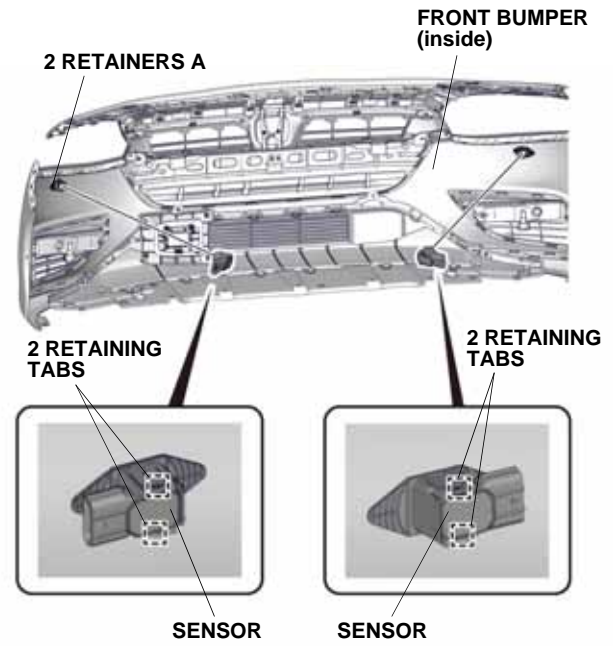

QG01065AH

109. Make sure the two sensors are installed properly.

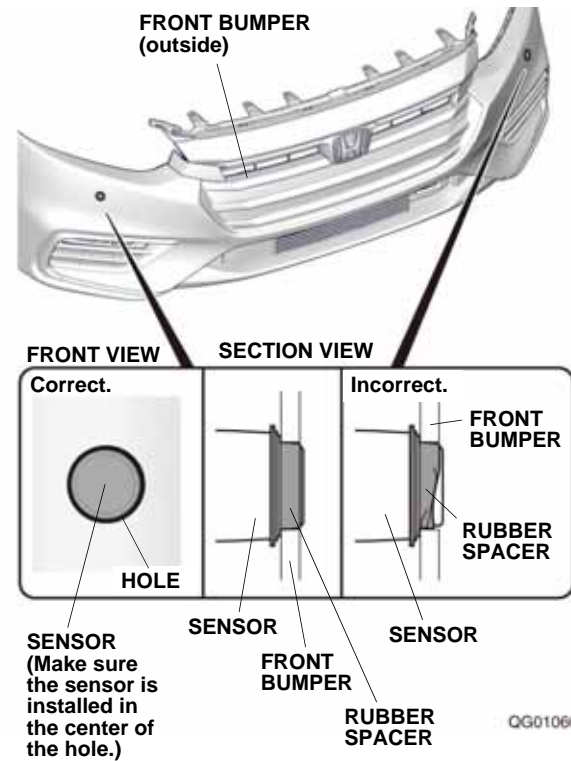

110. With the help of an assistant, bring the front bumper close to the vehicle, and plug the two front bumper harness 6-pin connectors into the two sensors as shown.

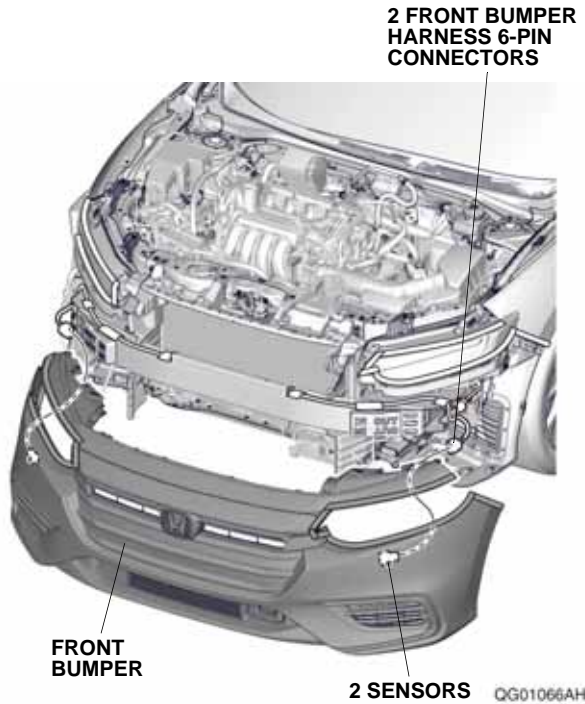

111. Mark the inside of the rear bumper. Using a pushpin, pierce the rear bumper at the center of the two scribe marks.  
NOTE: Pierce the scribe marks perpendicular to the rear bumper.

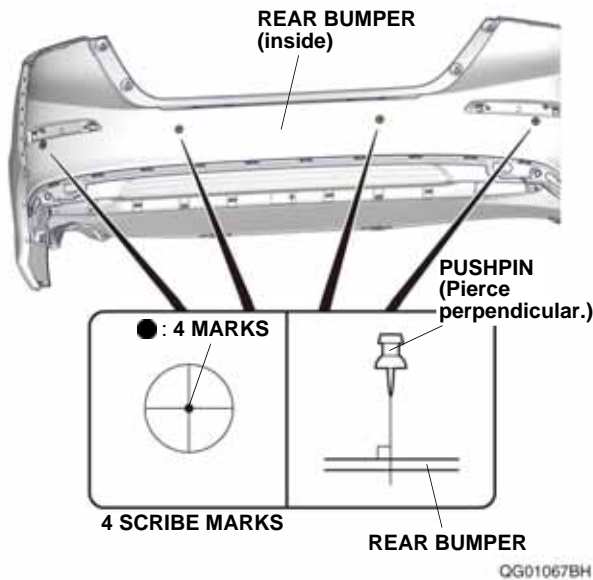

112. Using a felt-tip pen, mark the rear bumper as shown.

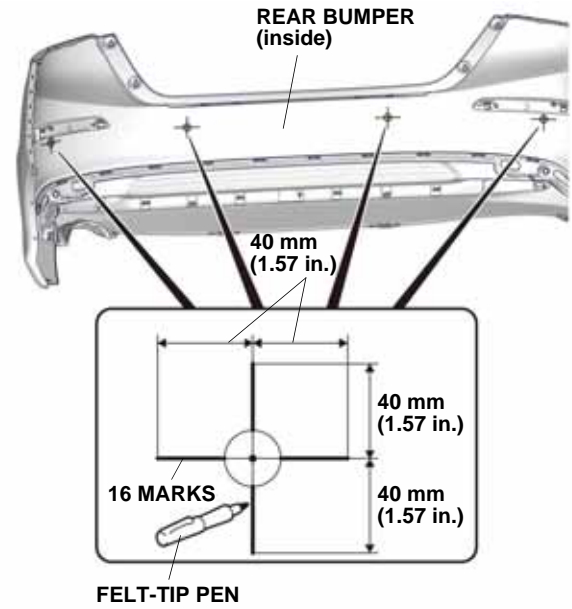

113. While wearing eye protection, drill the four pierced marks to 8.5 mm from the inside of the rear bumper. First, drill with a 3 mm drill bit, then follow with a 6 mm drill bit, and finish with an 8.5 mm drill bit.  
NOTE: Make sure to drill perpendicular to the rear bumper. Remove any burrs.

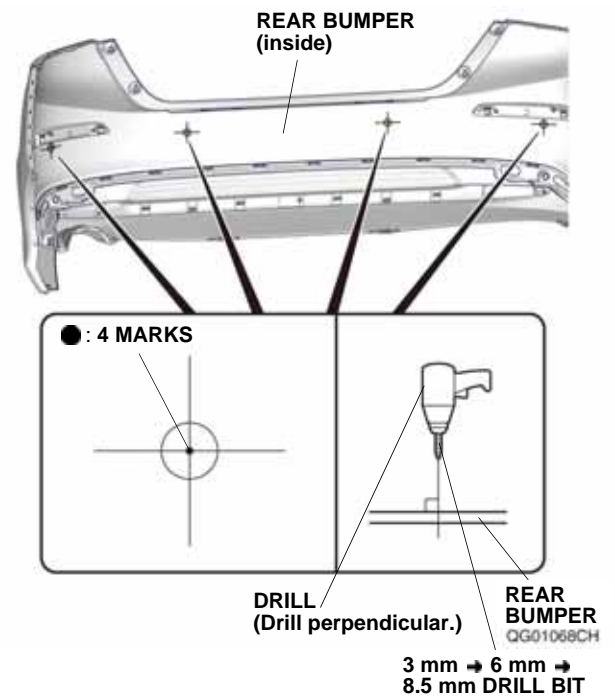

114. Using a 16 mm punch tool, punch out the four rear bumper holes as shown.  
 NOTE: Make sure to hold the punch perpendicular to the rear bumper. Remove any burrs.

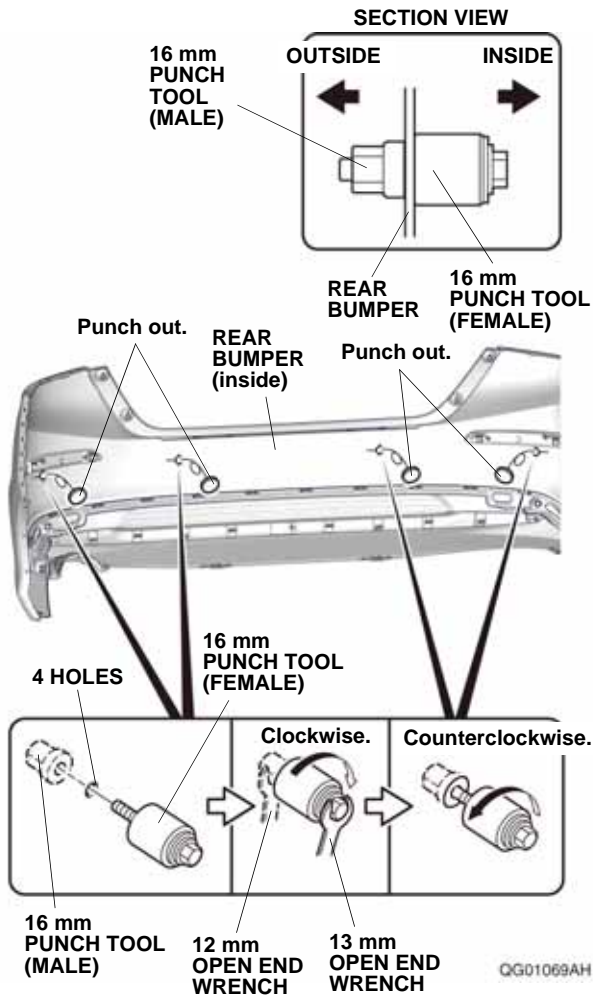

115. Install the four rubber spacers to the four sensors as shown.

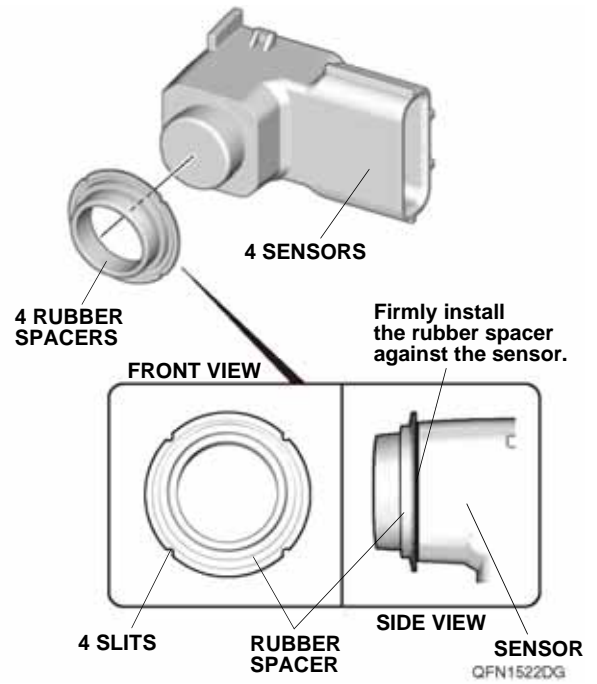

116. Using diagonal cutters, cut the two tabs off the retainers B as shown. Remove any burrs.

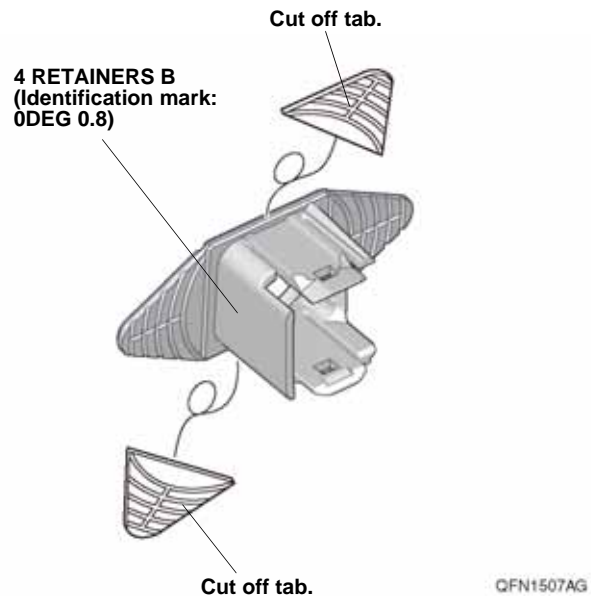

117. Install the four sensors to the four retainers B.

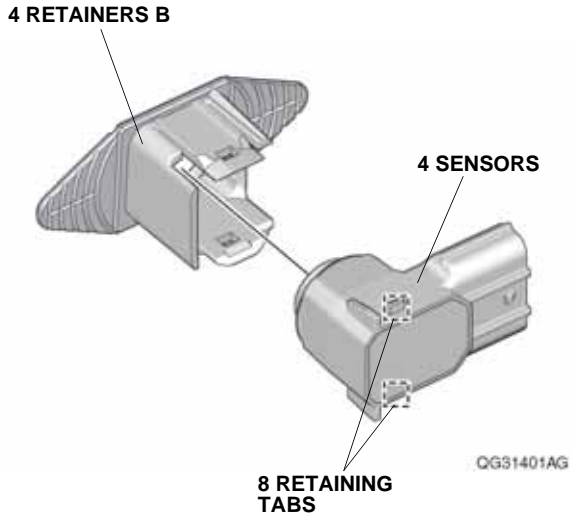

118. Line up the two sensors and two retainers B to the rear bumper as shown.

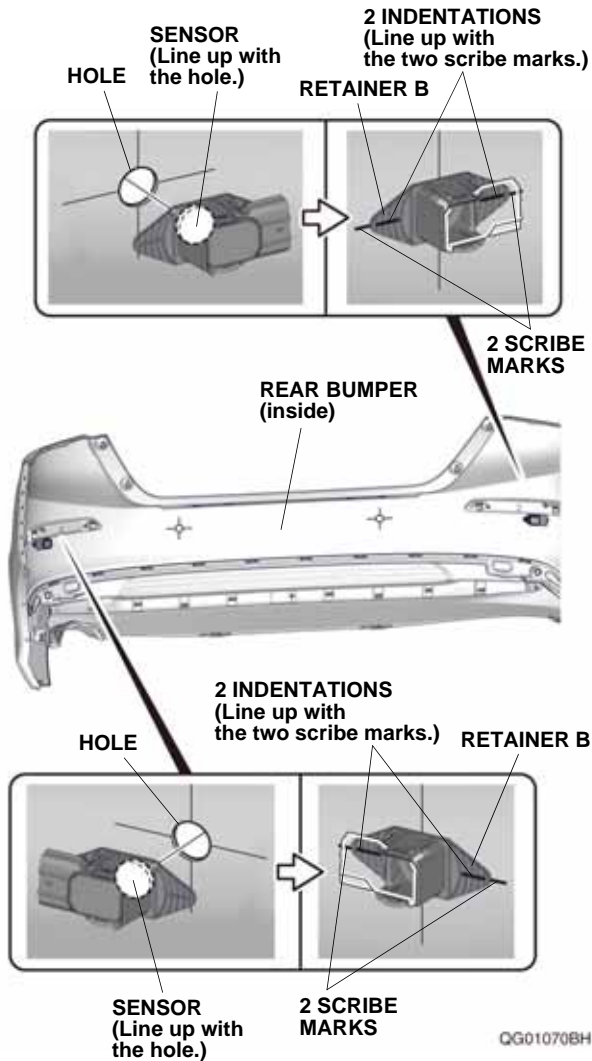

119. Line up the two sensors and two retainers B to the rear bumper as shown.

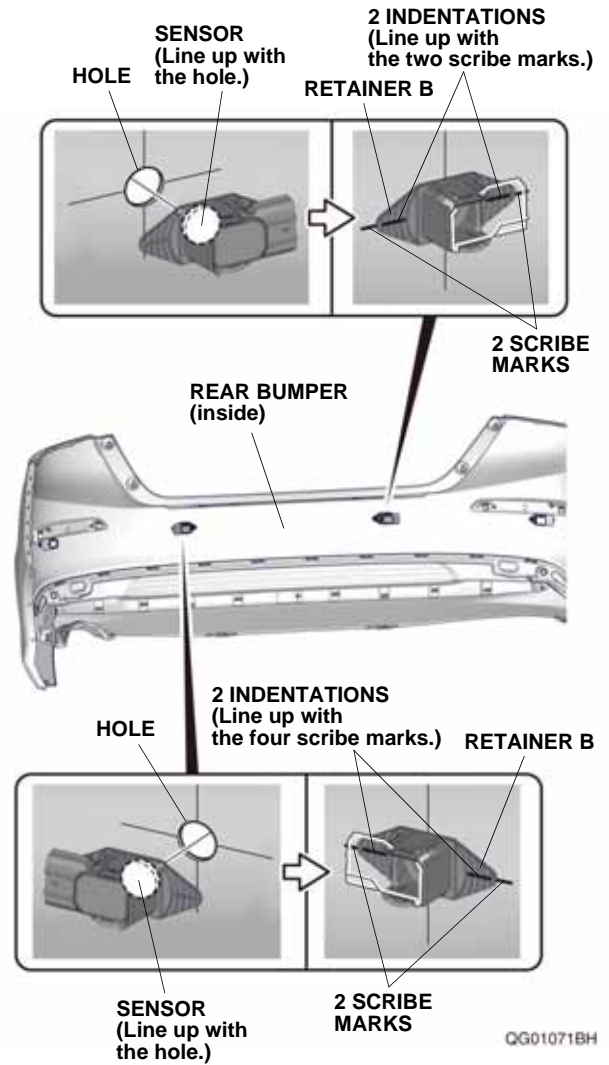

120. Make sure the four sensors are installed properly.

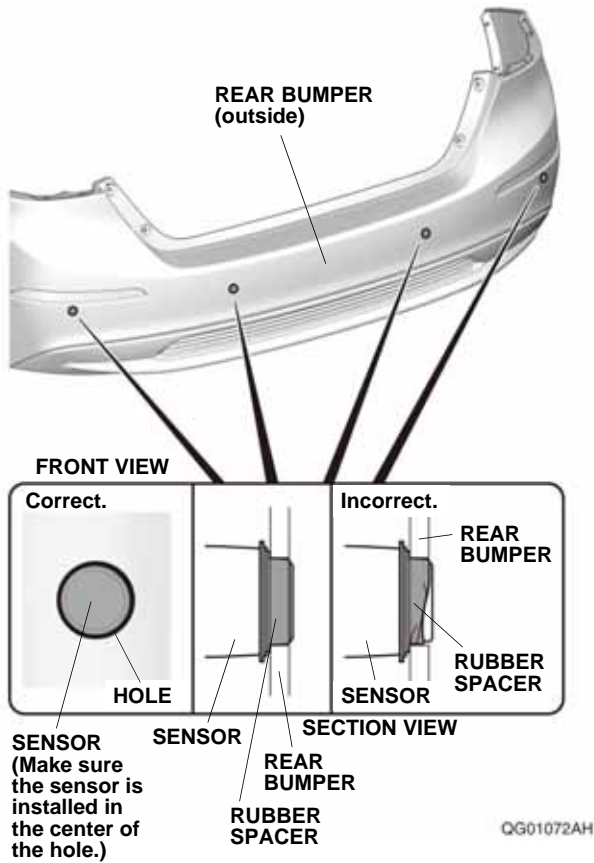

121. Using a felt-tip pen, mark the rear bumper as shown.

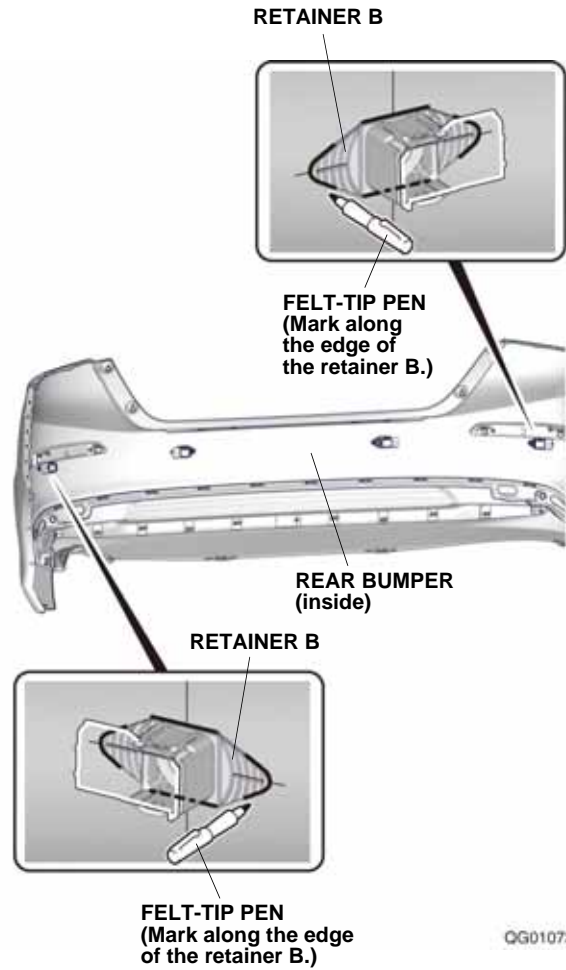



122. Using a felt-tip pen, mark the rear bumper as shown.

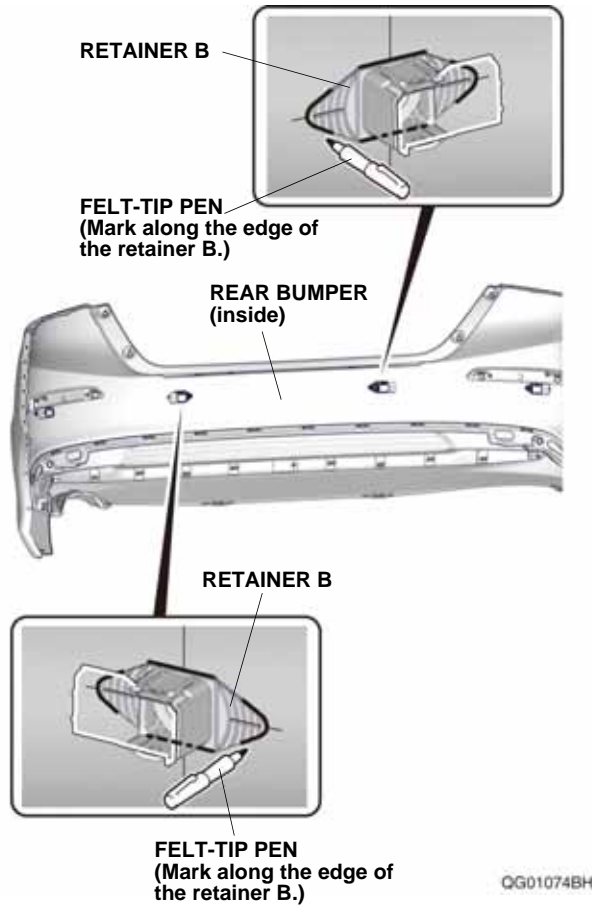

123. Using an alcohol wipe, thoroughly clean the rear bumper where the retainers B will attach.

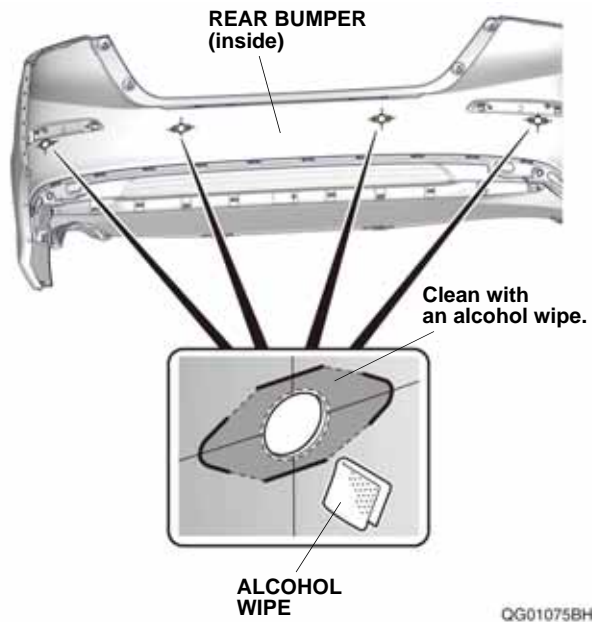

124. Apply the primer to the outer rear bumper holes.  
NOTE:

- Apply the primer evenly.
- Be careful not to apply the primer anywhere except the indicated area.
- Do not apply additional primer.
- Apply the primer, and let it dry for at least 10 minutes.
- Attach the rear retainers within 24 hours after applying the primer.
- Do not use an expired primer.

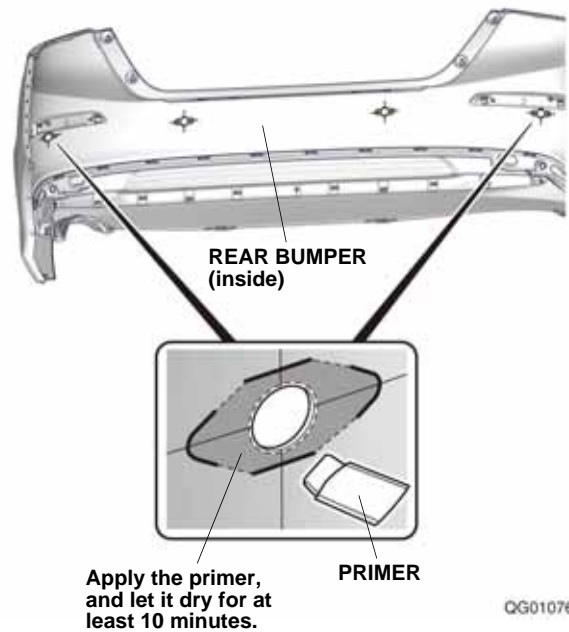

125. Apply the primer to the inner rear bumper holes.

NOTE:

- Apply the primer evenly.
- Be careful not to apply the primer anywhere except the indicated area.
- Do not apply additional primer.
- Apply the primer, and let it dry for at least 10 minutes.
- Attach the rear retainers within 24 hours after applying the primer.
- Do not use an expired primer.

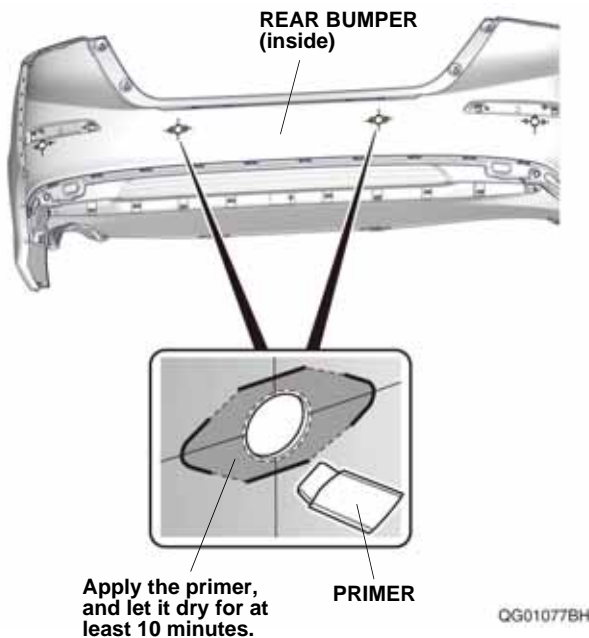

126. Remove the six adhesive backings from the two retainers B, and attach them to the rear bumper as shown.

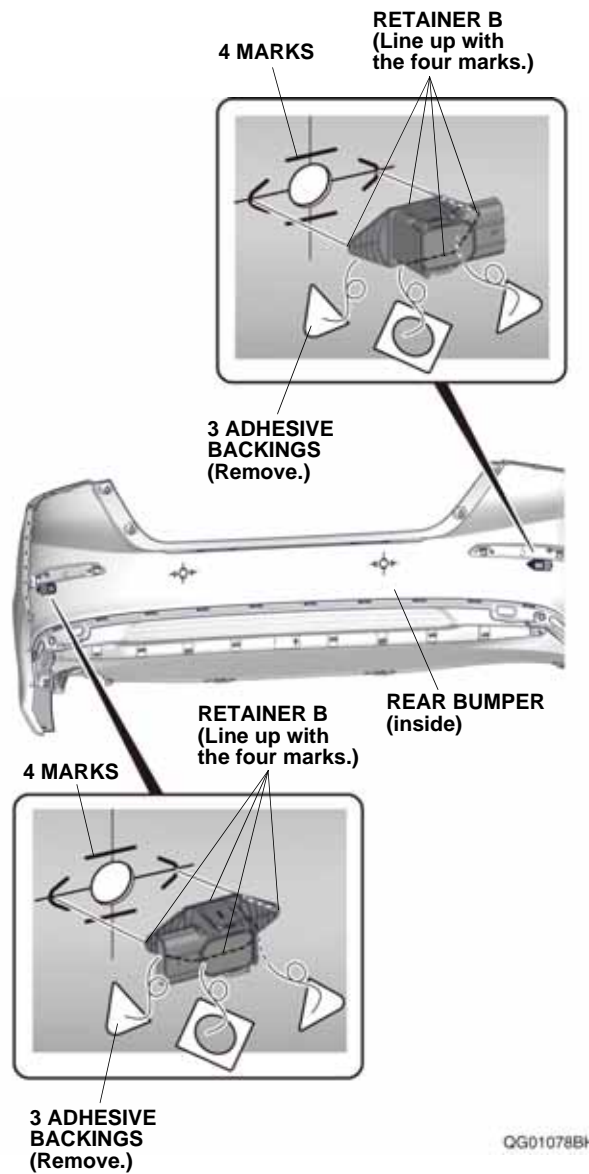

127. Remove the six adhesive backings from the two retainers B, and attach them to the rear bumper as shown.

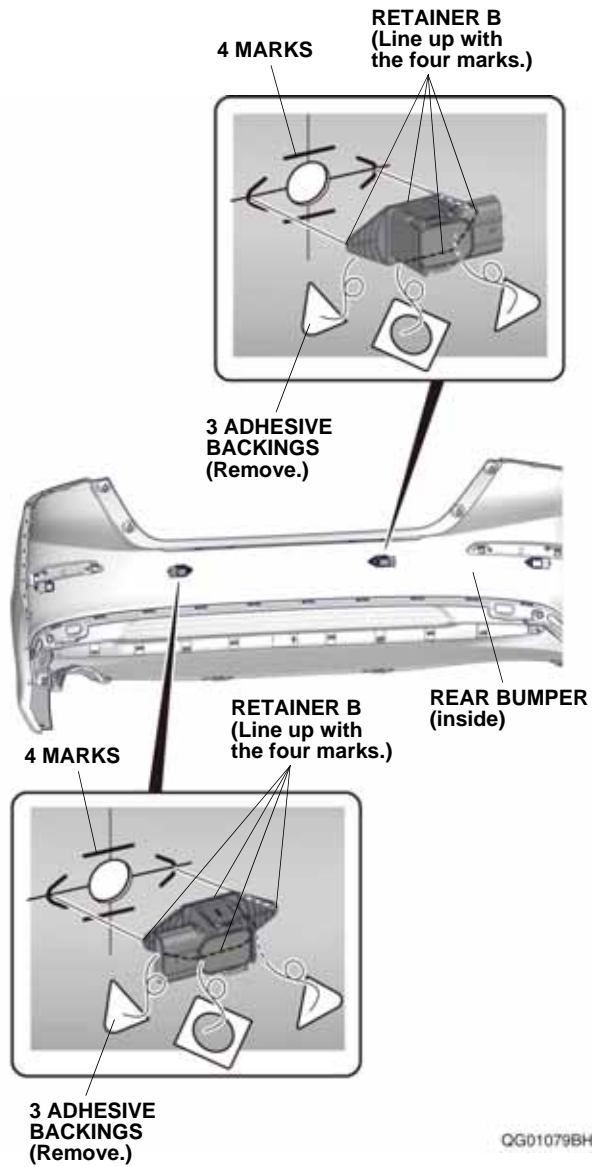

128. Remove the four sensors, and firmly press the four retainers B against the rear bumper. Install the four sensors.

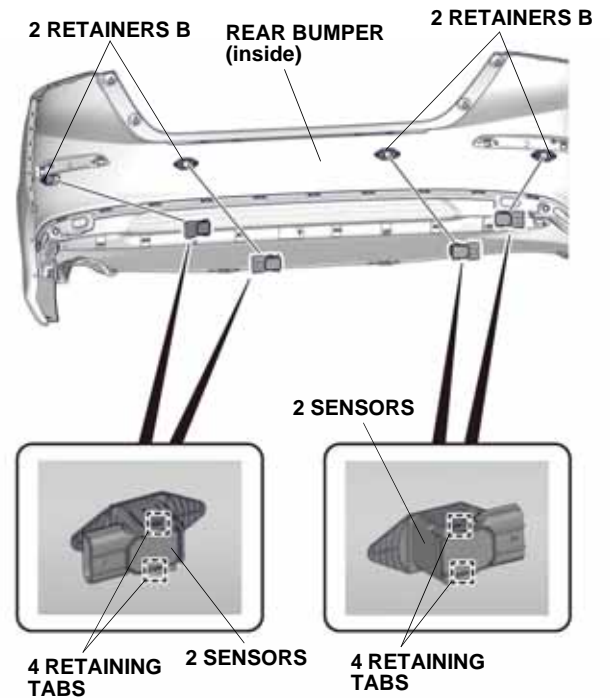

QG01080AH

129. Make sure the four sensors are installed properly.

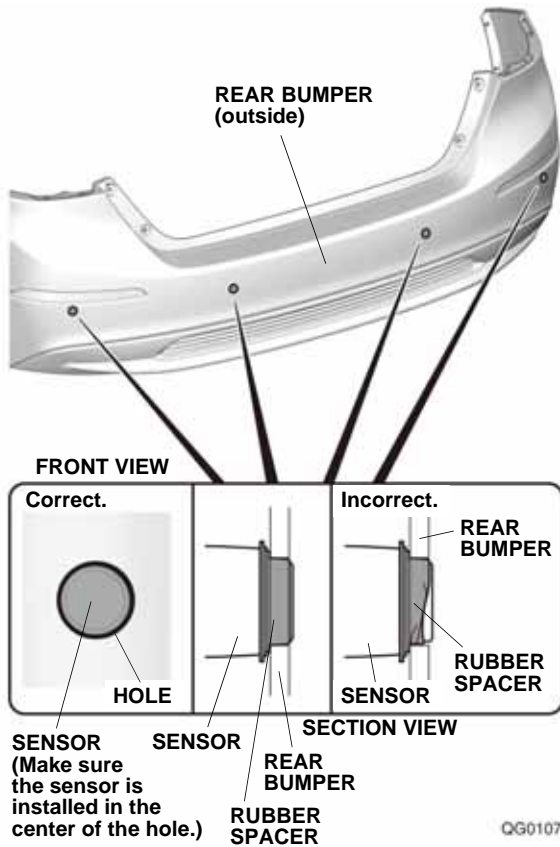

130. Plug the rear bumper harness 6-pin connectors into the four sensors.

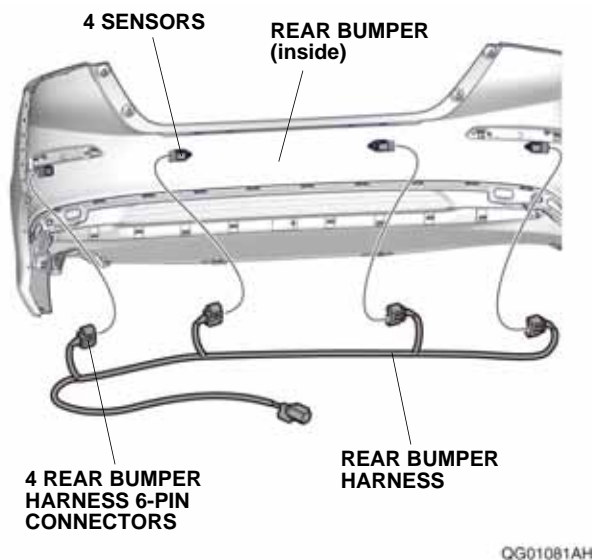

131. Using isopropyl alcohol on a shop towel, thoroughly clean the rear bumper where the aluminum tape will attach.

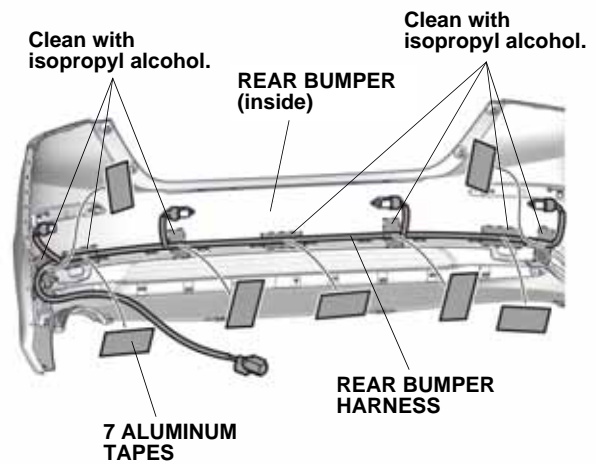

132. Secure the rear bumper harness to the rear bumper with pieces of aluminum tape as shown.

133. Remove the dummy connector from the vehicle 4-pin connector, and plug the rear bumper harness 4-pin connector into it.

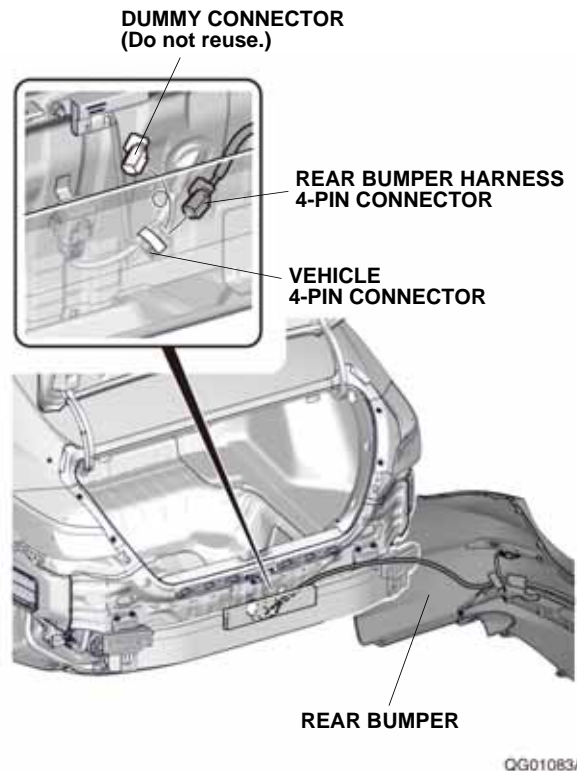

134. Using isopropyl alcohol on a shop towel, thoroughly clean the rear bumper beam where the aluminum tape will attach.

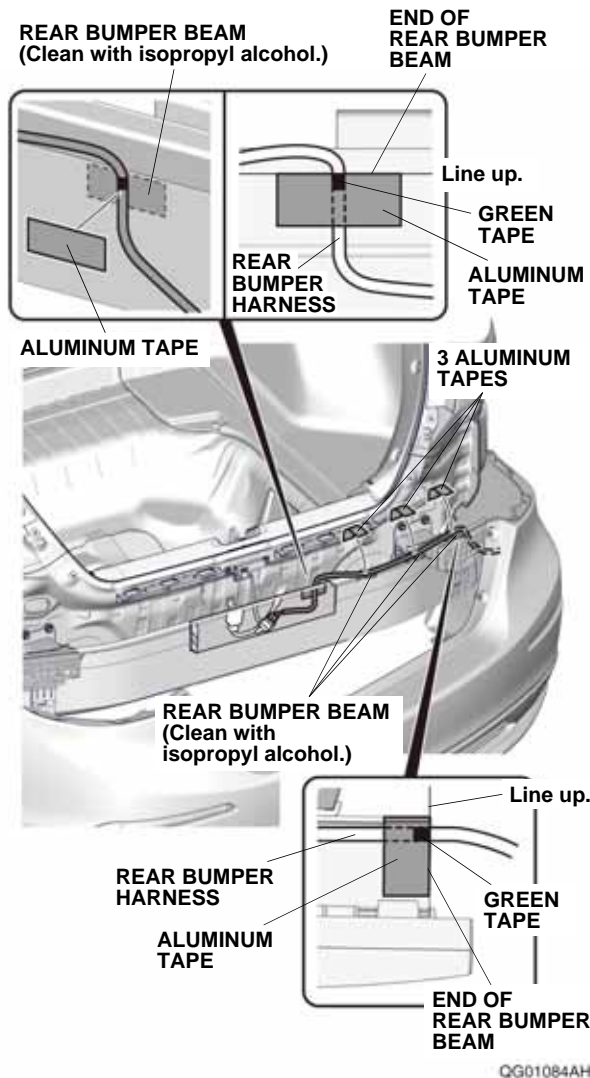

135. Secure the rear bumper harness to the rear bumper beam with the four pieces of aluminum tape as shown.
136. Install the rear bumper.

137. Check that all wire harnesses are routed properly and that all connectors are plugged in.
138. Install all removed parts except for the right side panel.
139. Connect the negative cable to the battery.
140. Install the right side panel.
141. Press and hold the audio unit power button for 2 seconds to restore the audio and navi (if equipped) system functions.
142. Set the clock on vehicles without navigation.
143. If necessary, restore the systems back to normal operation as described in the service information.

### Initial Settings of the Parking Sensors

144. Turn the power switch to ON.
145. Press the sensor switch 10 times in 10 seconds.
146. Make sure the indicator in the sensor switch blinks.
147. Turn the power switch to OFF.
148. Turn the power switch to ON while press the sensor switch. Hold the sensor switch for about 10 seconds, and check that the buzzer beeps for 2 seconds.

### Check the Operation of the Parking Sensors

149. Check that the parking sensors work properly as described in the accessory user's information manual in this kit.