

INSTALLATION INSTRUCTIONS	Accessory	Application	Publications No. VERSION 1
	PREMIUM CABIN AIR FILTER	MULTIPLE MODELS	Issue Date APR 2023

GENERAL VIEW

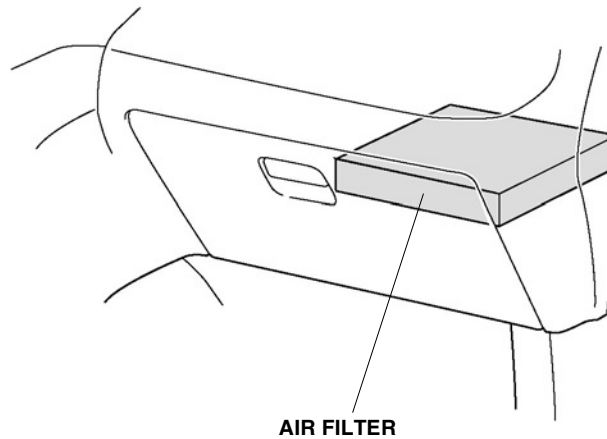

QM00201AT

FOR YOUR SAFETY (Read carefully.)

Warning Symbols

Safety: Your safety, and the safety of others, is important. To help you make informed decisions about service procedures, we have provided safety messages where appropriate. Of course, it is not practical or possible to warn you about all the hazards associated with servicing a vehicle - you must use your own good judgment.

You will find important safety messages preceded by one of the following symbols:

*All symbols are not used in all installation instructions.

⚠ DANGER

You will be killed or seriously hurt if you do not follow the instructions.

⚠ WARNING

You can be killed or seriously hurt if you do not follow the instructions.

⚠ CAUTION

You can be hurt if you do not follow the instructions.

NOTICE

Gives advice to prevent damage to the product, vehicle, the environment or other property.

NOTE

Gives helpful information or instructions to be followed when installing this product.



Indicates a prohibited action.

Procedure and Location Icons

These icons indicate the work location and the worker's point of view.

*All icons are not used in all installation instructions.

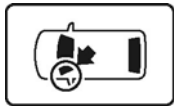

The location on the vehicle.

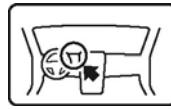

The location in the vehicle.
(Instrument panel.)



Wear eye protection.



Wear heavy gloves.



Use an assistant.



Place the part on a blanket.



Work perpendicular.



Remove any burrs.



Use touch-up paint and allow to dry.



Tighten to the specified torque.



Apply firm pressure while rolling, especially at the ends, to set the adhesive.



Press firmly.



Clean with isopropyl alcohol.



Return the original part to the customer.
(Do not reuse.)

Safety: General

- Observe all safety notes and precautions described in the service information, in addition to those described in this Installation Instruction. Be extremely careful for your safety and the safety of others.
- Be careful not to damage the vehicle or the parts.
- The illustrations may differ slightly from the actual accessory.

Safety: Accessory

Always use the parts and tools specified in the installation instructions.

PARTS LIST

Premium Cabin Air Filter Kit
(P/N 08R79-PS8-100A)
(P/N 08R79-PS8-100B)

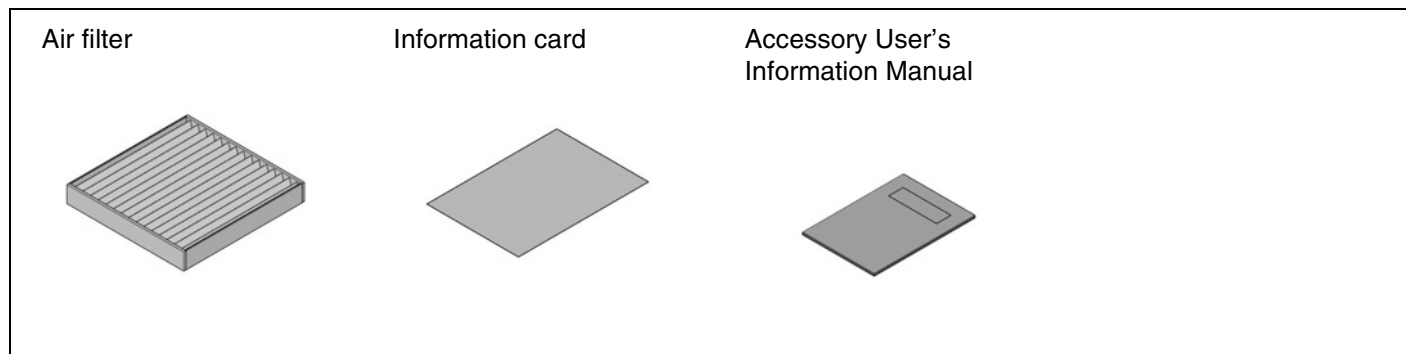

REQUIRED TOOLS AND SUPPLIES

Felt-tip pen

INSTALLATION

1. For the air filter installation, refer to the Service Manual for each applicable model.
2. Fill in due date for the next service due on the information card. The recommended replacement timing is one year or 12,500 miles (20,117 km) under normal conditions. Refer to the Accessory User's Information Manual for all conditions to consider when replacing the air filter.

INFORMATION CARD

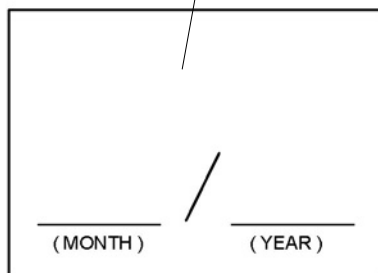

QM00202CT

3. Store the information card inside the vehicle.
4. Give the Accessory User's Information Manual to the customer.