



## INSTALLATION INSTRUCTIONS

Accessory

FRONT UNDER SPOILER

Application

2007 ODYSSEY

Publications No.

All 33173

Issue Date

JULY 2006

### PART LIST

Front under spoiler

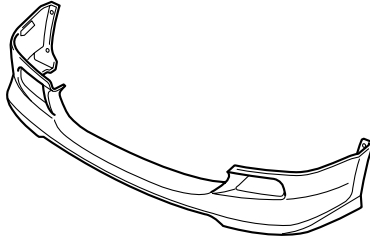

5 Stepped bolts

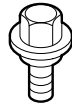

2 Square head bolts



2 Washer-nuts



4 Self-tapping screws



4 Spring nuts



### TOOLS AND SUPPLIES REQUIRED

Phillips screwdriver

Flat-tip screwdriver

Ratchet

10 mm Socket

Drill

3 mm, 6 mm, 8 mm and 10 mm Drill bits

Center punch

File

Blanket

Masking tape

Isopropyl alcohol

Shop towel

Eye protection (face shield, safety goggles, etc.)

### INSTALLATION

**Customer Information:** The information in this installation instruction is intended for use only by skilled technicians who have the proper tools, equipment, and training to correctly and safely add equipment to your vehicle. These procedures should not be attempted by "do-it-yourselfers."

#### NOTE:

- Be careful not to damage the front bumper and body paint finish.
- This front under spoiler kit should be installed only if the ambient air temperature is 60°F (15°C) or above.
- To allow the adhesive to "cure", do not wash the vehicle for 24 hours.

1. Remove the front bulkhead cover (ten clips).

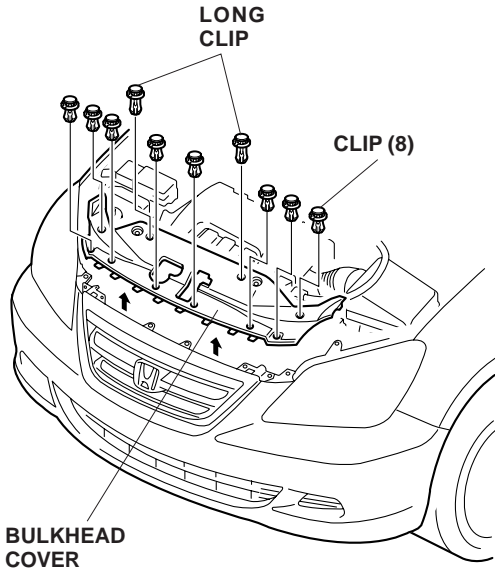

2. Remove the front bumper (two bolts, eight clips, and two self-tapping screws and pull the bumper out towards you). If equipped, unplug the fog light connectors. If equipped, unplug the front corner sensor connectors. Place the front bumper on a blanket to install the front under spoiler.

## Without Fog Lights and Front Corner Sensors:

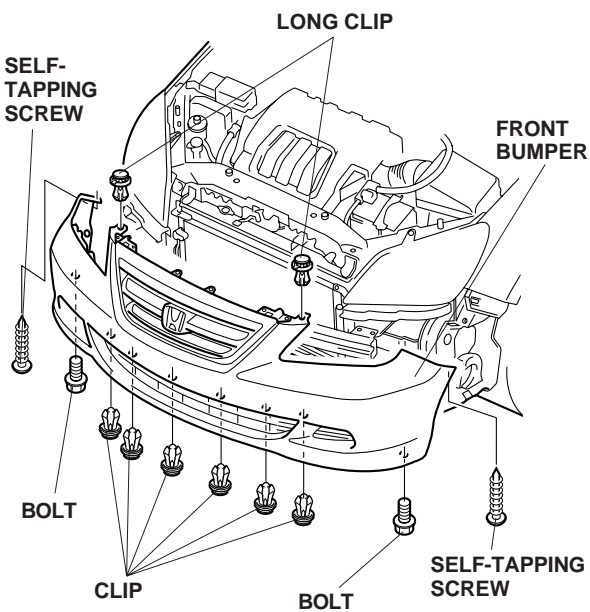

## With Fog Lights:

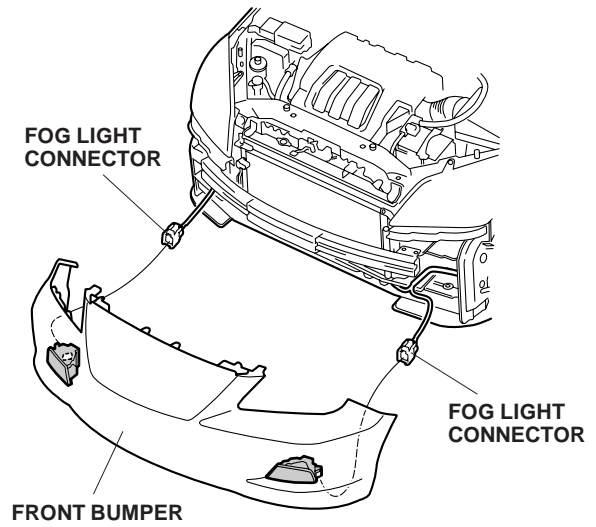

## With Front Corner Sensors:

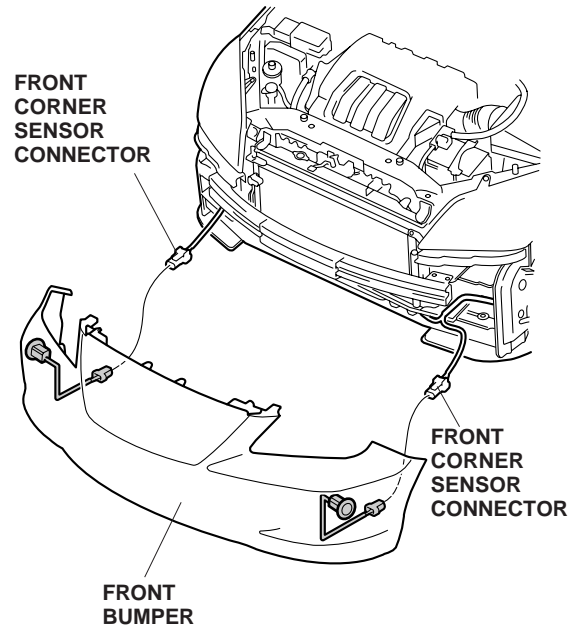

3. Locate the four dimples at the fenderwell area of the front bumper. While wearing eye protection, drill a 6 mm hole through each dimple. Start with a 3 mm drill bit and finish with a 6 mm drill.

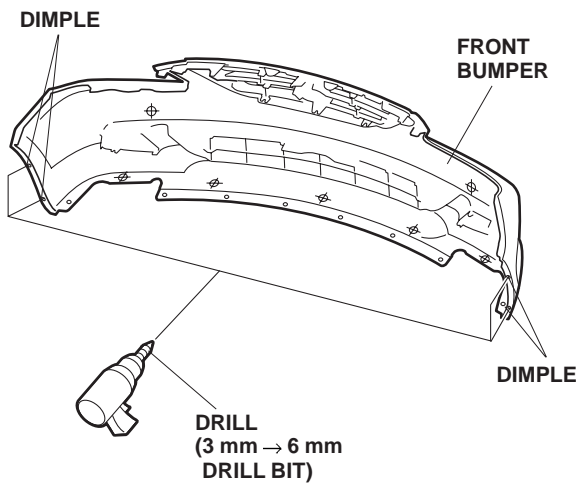

4. On the inside of the bumper, locate the seven scribed marks. Center punch each scribed mark.

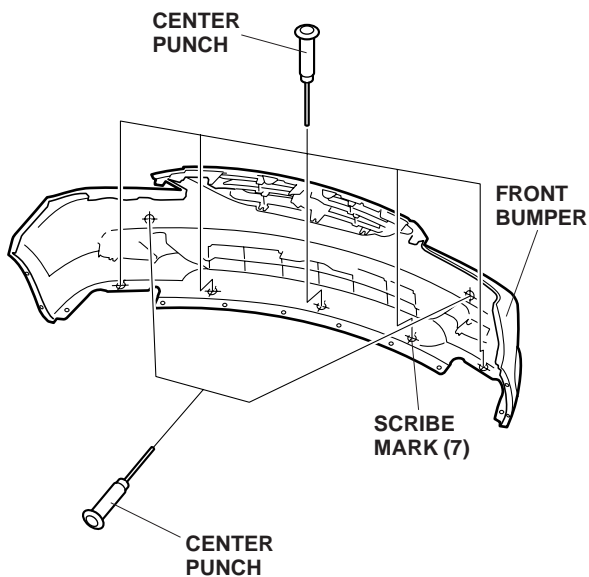

5. While wearing eye protection, drill two 8 mm holes through the front bumper. First drill with a 3 mm drill bit, then finish with an 8 mm drill bit.

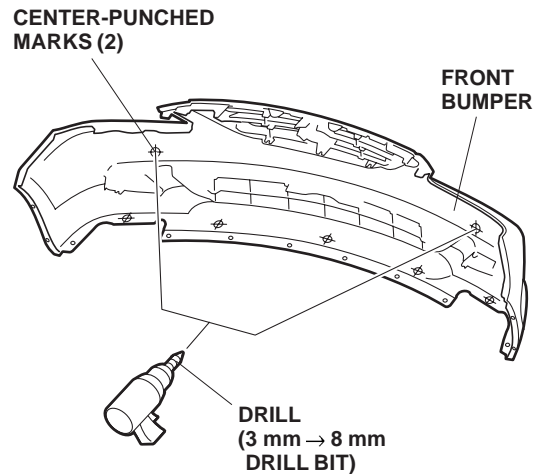

6. While wearing eye protection, drill five 10 mm holes through the five center-punched marks along the bottom of the bumper. First drill with a 3 mm drill bit, then with a 6 mm drill bit, and finish with a 10 mm drill bit.

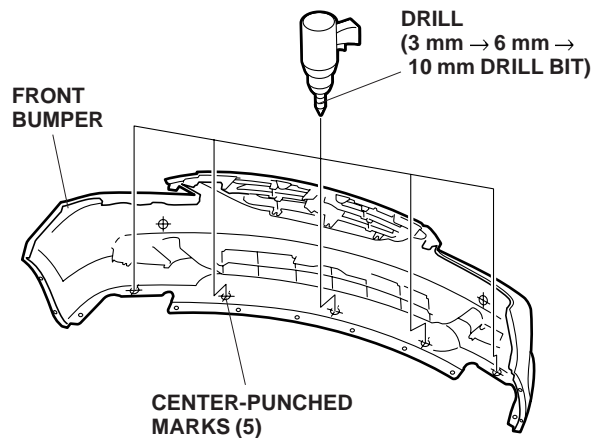

7. Using a file, remove any burrs from the drilled holes.

8. Slide one spring nut over each of the four holes you drilled at the fenderwell area of the bumper.

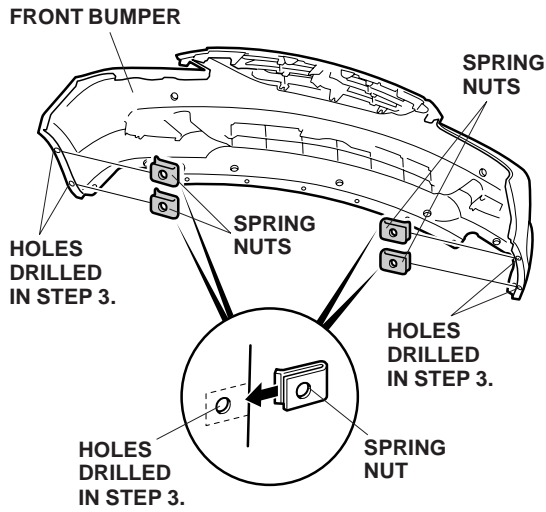

9. Slide one square head bolt into each bracket on the front under spoiler.

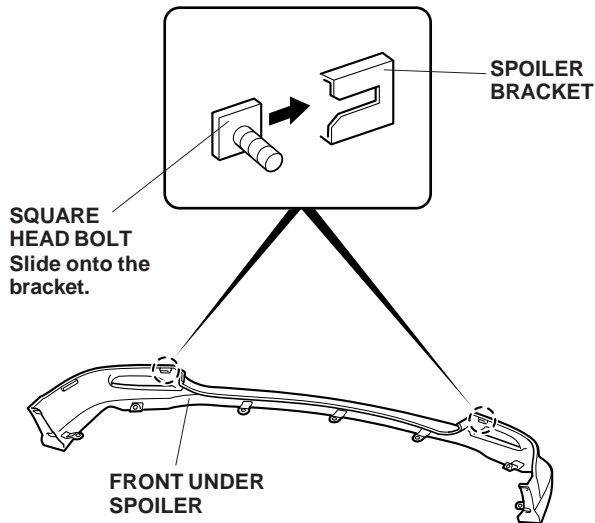

10. Attach a strip of masking tape to the end of each adhesive backing, then pull back 1½ to 2 inches of the adhesive backing. Fold the ends back, and tape them to the front of the spoiler.

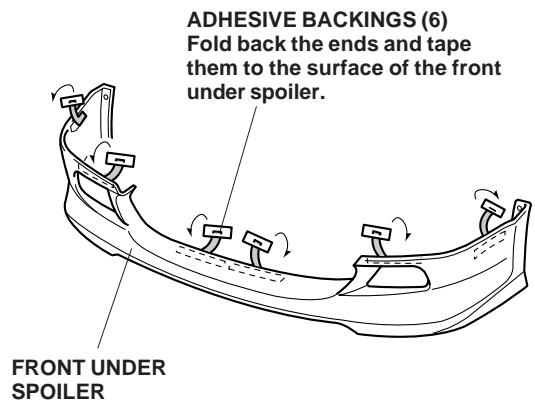

11. Using isopropyl alcohol on a shop towel, clean the front bumper where the under spoiler will attach.
12. Position the under spoiler on the front bumper, and install a washer-nut to each square-head bolt.

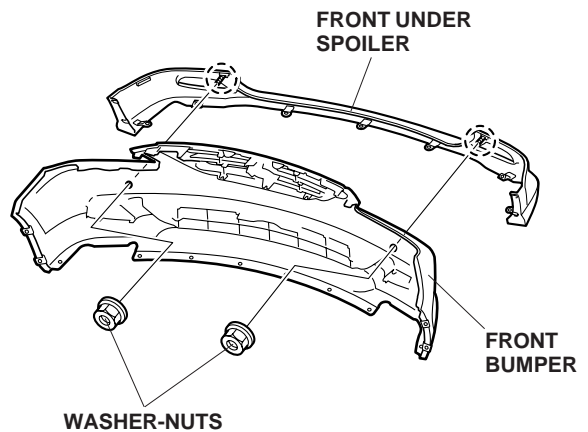

- Secure the front bumper to the front under spoiler using the five stepped bolts.

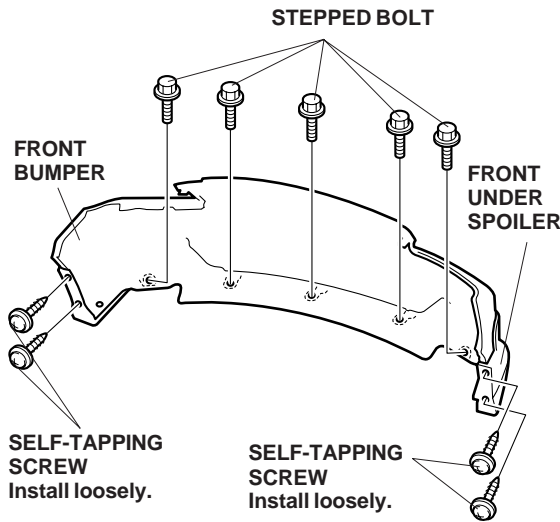

- At the edge of the spoiler/bumper, loosely install the four self-tapping screws.
- With the help of an assistant, gently pull the sides of the bumper around the fenderwell and install the front bumper. If equipped, plug in the fog light connectors. If equipped, plug in the front corner sensor connectors. Make sure the center rubber splash protector is above the bottom bumper edge. Reinstall the six clips, two bolts, and two self-tapping screws to secure the bumper.

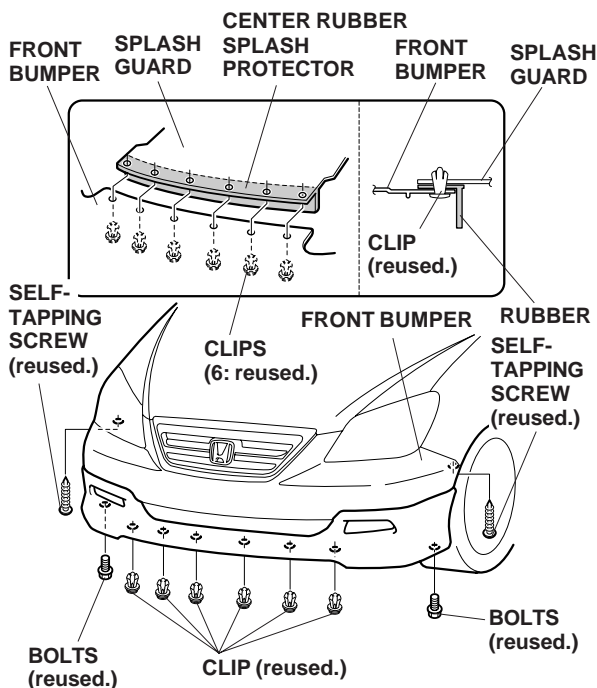

- While holding light pressure on the spoiler, carefully remove the adhesive backings. Hold the spoiler firmly against the front bumper with the palm of your hand for 30 seconds, particularly at the edges.

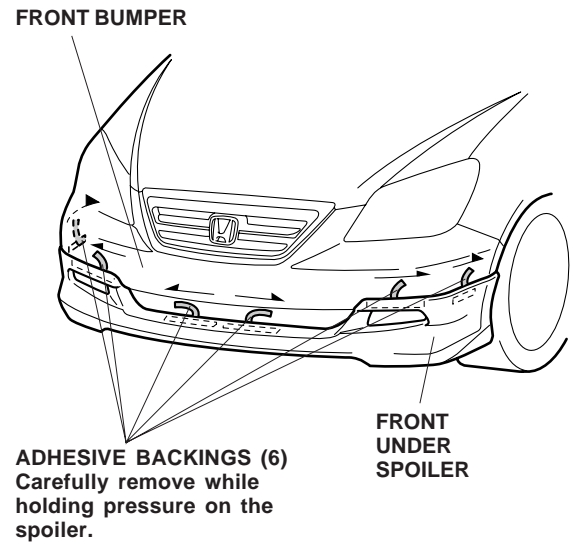

- While holding the edge of the spoiler against the bumper, tighten the four self-tapping screws installed in step 14.

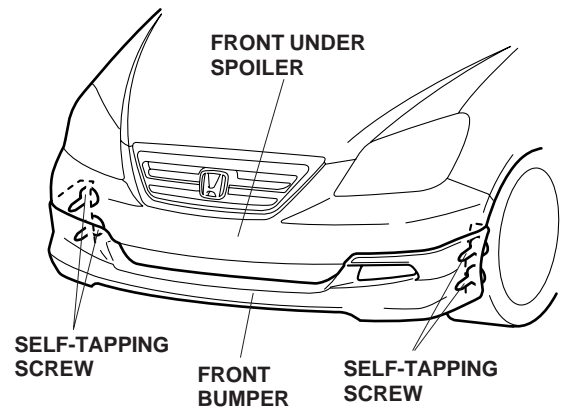

- Reinstall the front bulkhead cover.

**Give a copy this page to your customer.**

- When towing Odyssey, follow the instructions described in the vehicle Owner's Manual.
- When using the front towing hook, make sure to remove the front bumper with front under spoiler. Failure to follow this precaution could damage the vehicle, the front bumper, and the front spoiler.

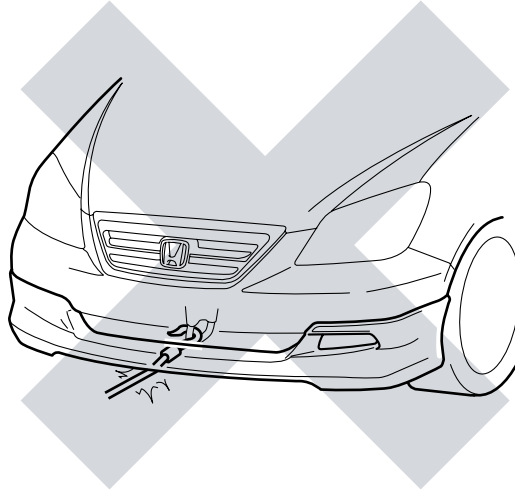



## INSTALLATION INSTRUCTIONS

Accessory

SIDE UNDER SPOILER

Application

2007 ODYSSEY

Publications No.

All 33187

Issue Date

JULY 2006

### PARTS LIST

Left side under spoiler

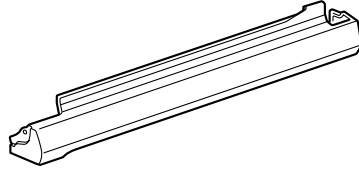

Right side under spoiler

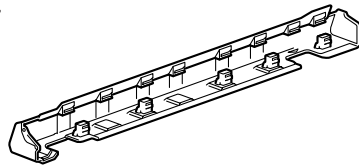

26 Seals

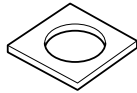

### TOOLS AND SUPPLIES REQUIRED

Phillips screwdriver

Blanket

### INSTALLATION

#### NOTE:

- To prevent damage, place a blanket under the side under spoilers during installation.
- These instructions show the left side under spoiler being installed. The same procedure applies to installing the right side under spoiler.
- Optional splash guards cannot be used with the side under spoilers.

1. Open the front and rear doors. Remove the self-tapping screw that fasten the left side sill panel to the left front inner fender. Slide the side sill panel forward, then remove it by pulling it out toward you.

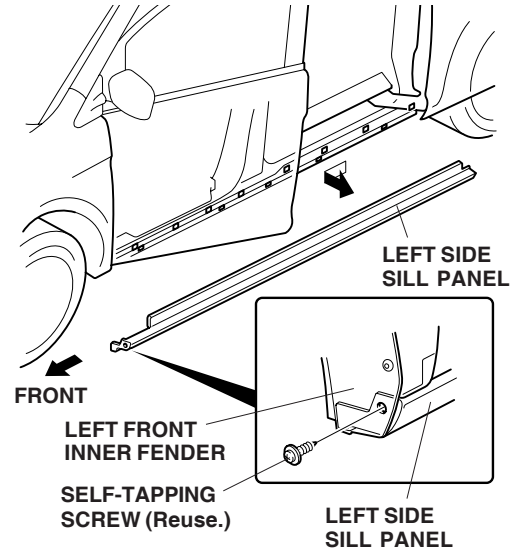

2. Remove the 13 clips from the side sill by turning them 45°.

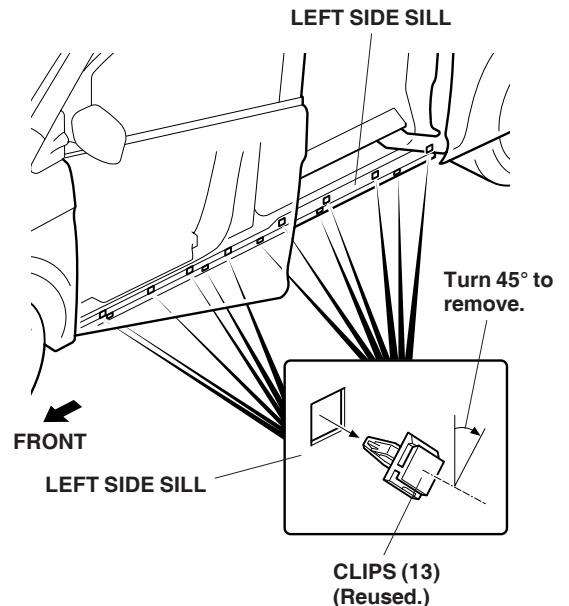

- On the inside of the new under spoiler, install the 13 clips you removed to the holders through the cutout as shown. Make sure the clips fit properly in the cutouts.

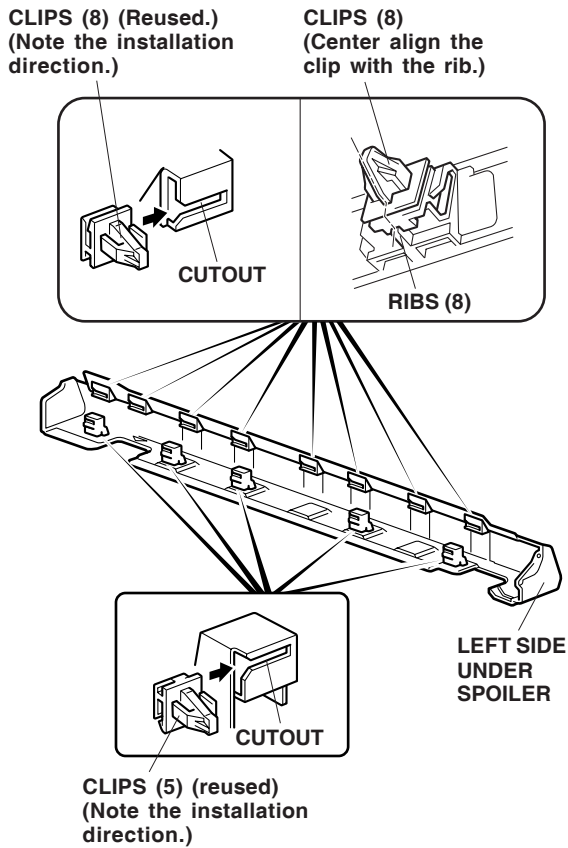

- Remove the old seals from the 13 clips, and install the new seals from the kit.

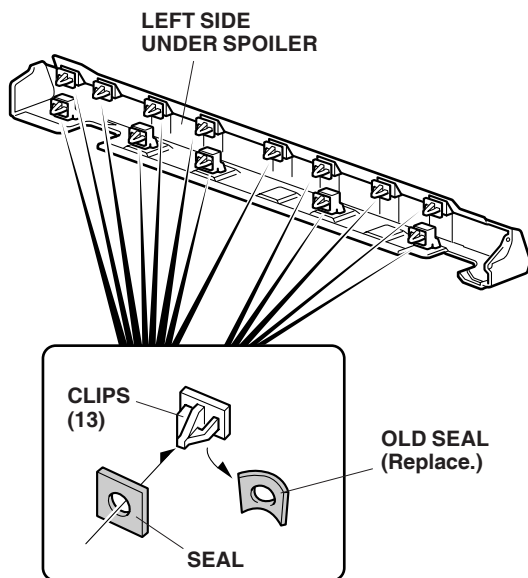

- Position the left side under spoiler on the body under the front inner fender, and push the clips you just installed into the square holes in the body. Use the palm of your hand to click all 13 clips into place.

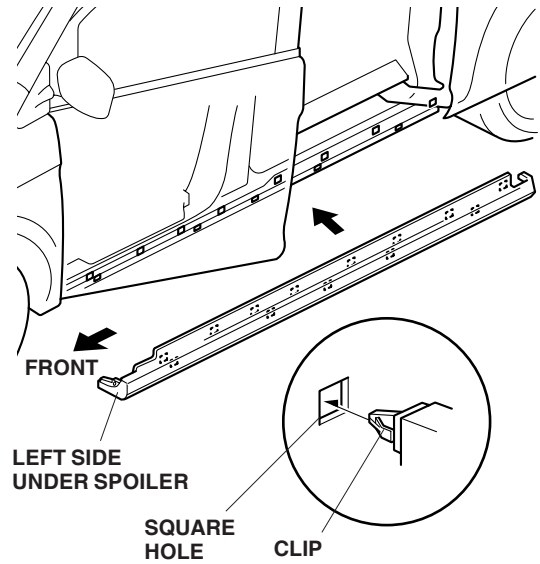

- Reinstall the self-tapping screw removed in step 1.

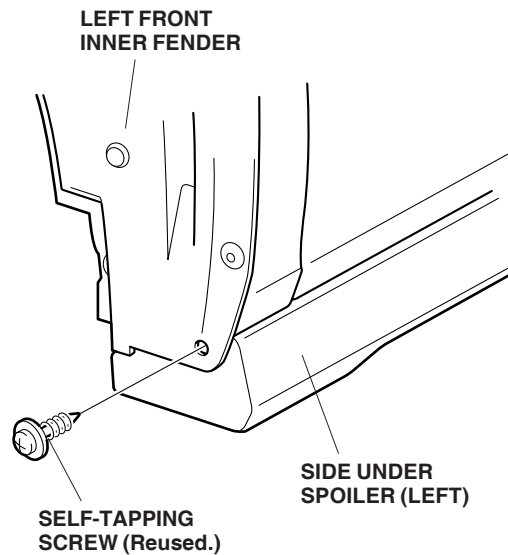

- Repeat steps 1 thru 6 to install the right side under spoiler.



## INSTALLATION INSTRUCTIONS

Accessory

REAR UNDER SPOILER

Application

2007 ODYSSEY

Publications No.

All 33181

Issue Date

JULY 2006

**NOTE:** Optional splash guards cannot be used with this rear with this rear under spoiler.

### PARTS LIST

Rear under spoiler

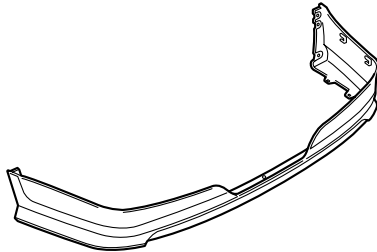

5 Long Stepped bolts

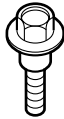

4 Short Stepped bolts



6 Square head bolts

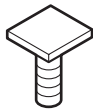

2 Self-tapping screws

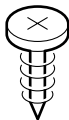

15 Washer-nuts



2 Spring nuts



4 Adhesive Collars



### TOOLS AND SUPPLIES REQUIRED

Phillips screwdriver

Flat-tip screwdriver

Ratchet

10 mm Socket

Drill

3 mm, 8 mm, and 10 mm Drill bits

Clip remover

Felt-tip pen

File

Isopropyl alcohol

Shop towel

Masking tape

Blanket

Pushpin

Eye protection (face shield, safety goggles, etc.)

### INSTALLATION

**Customer Information:** The information in this installation instruction is intended for use only by skilled technicians who have the proper tools, equipment, and training to correctly and safely add equipment to your vehicle. These procedures should not be attempted by "do-it-yourselfers."

#### NOTE:

- Be careful not to damage the rear bumper and body paint finish.
- To prevent damage, rest the rear bumper on the blanket during the installation.
- This rear under spoiler kit should be installed only if the ambient air temperature is 60°F (15°C) or above.
- To allow the adhesive to "cure", do not wash the vehicle for 24 hours.

- Remove the rear bumper:
  - If equipped, remove two screws and three clips that secure the inner fender.
  - Remove the four self-tapping screws (two on each side) at the fenderwell.
  - Using a clip remover, pry out and remove the three clips along the bottom of the bumper.
  - Using a flat-tip screwdriver, pry out and remove the bumper bolt cover covers, then remove the four bumper bolts.
  - With the help of an assistant, release the bumper from the fenderwell, and slide the bumper away from the vehicle.
  - If equipped, unplug the backup sensor connectors.
  - Set the bumper on a blanket.

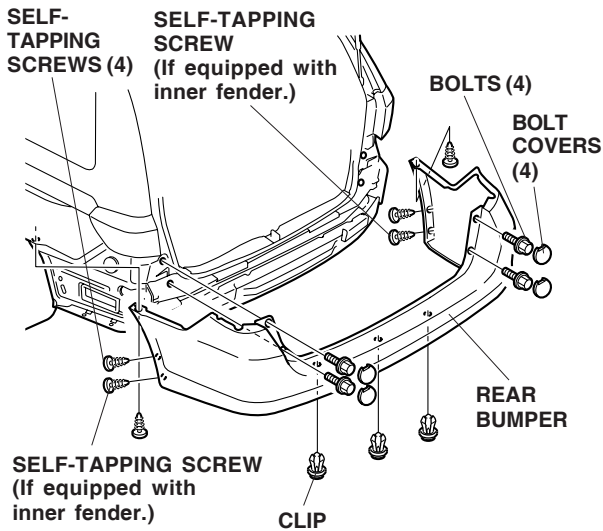

- On the inside of the bumper, locate the 13 marked areas. Using a pushpin, pierce the bumper at the 13 locations identified below. Double-check your marks before piercing through the bumper.
  - MARK NOT USED (Do not pierce through this mark.)
  - MARK NOT USED (Do not pierce through this mark.)
  - REAR UNDER SPOILER MARK (Mark in the same position on the other side.)

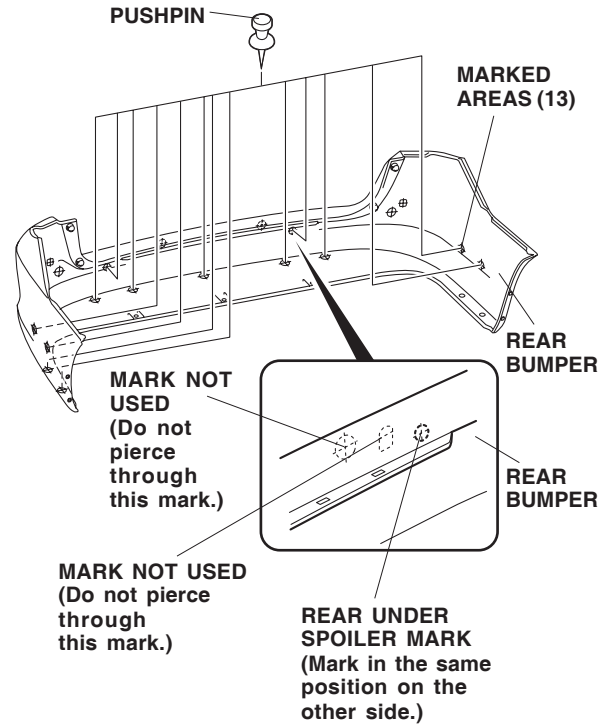

- While wearing eye protection, drill an 8 mm hole through the two rear marks and the four side marks.
  - First drill with a 3 mm drill bit, then finish with an 8 mm drill bit.
  - Remove any burrs from the edges of the holes with a file.

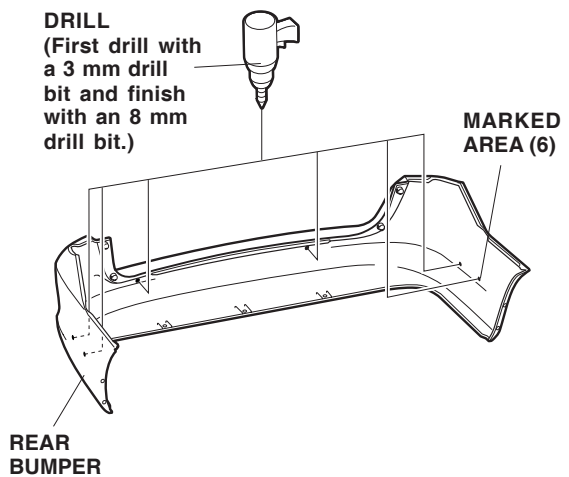

- Turn the bumper upside down. While wearing eye protection, drill a 10 mm hole through each of the seven marks and two slots:
  - First drill with a 3 mm drill bit, then finish with a 10 mm drill bit.
  - Remove any burrs from the edges of the holes with a file.

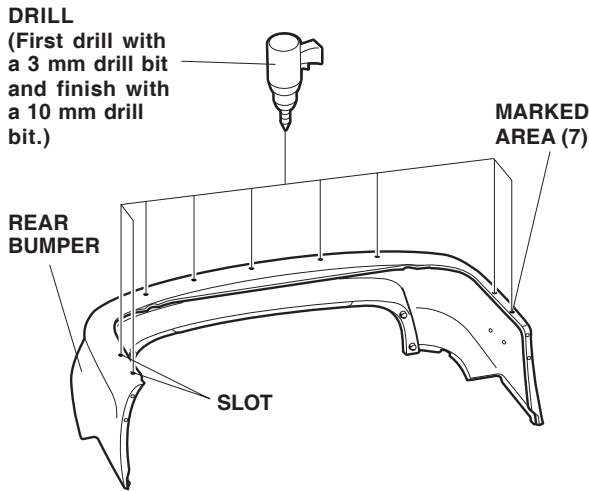

- On the inside of the rear under spoiler, locate the six brackets (three on each side). Slide one square head bolt into each bracket on the rear under spoiler.

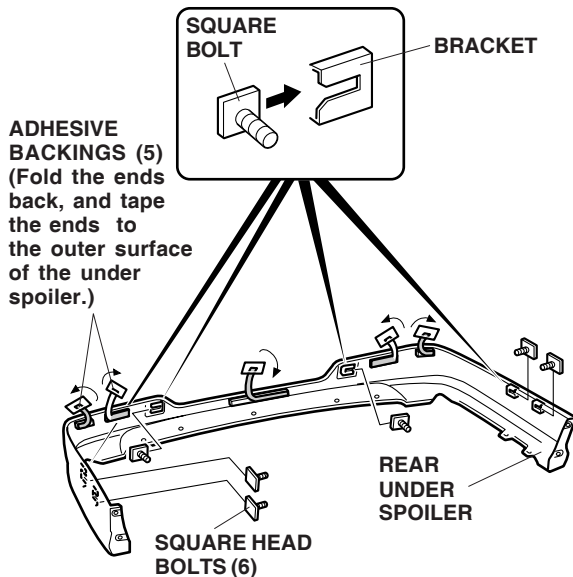

- Attach a strip of masking tape to the end of each adhesive backing, then pull back 1½ to 2 inches of adhesive backing. Fold the ends back, and tape them to the outer surface of the spoiler with masking tape.

- Using isopropyl alcohol on a shop towel, clean the rear spoiler areas where the adhesive collars will attach. Remove the adhesive backing from each adhesive collar, and attach the collar to the inside of the rear spoiler in the areas shown.

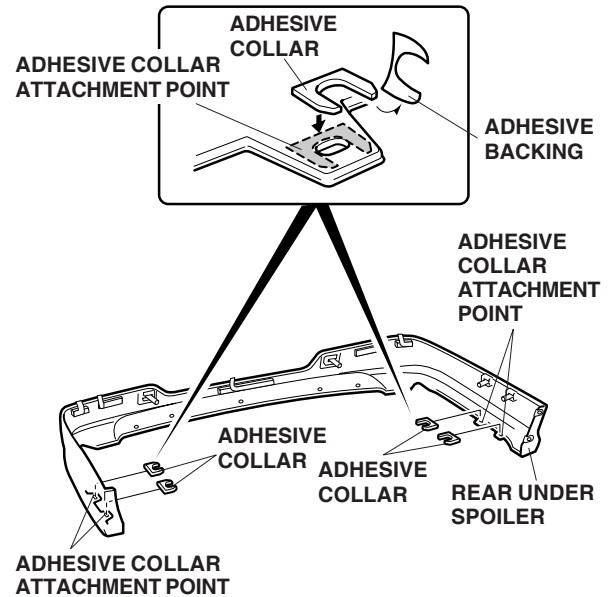

- LX model only: Install one spring nut to the lower bumper hole on each side at the fenderwell.

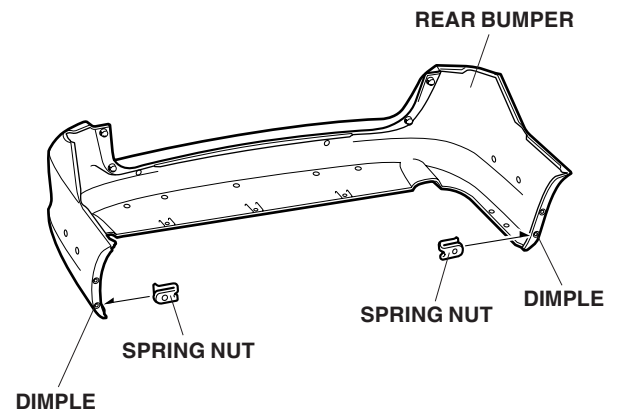

- Using isopropyl alcohol on a shop towel, clean the rear bumper where the rear under spoiler will attach.

10. Position the rear under spoiler on the rear bumper, and install a washer nut to each square-head bolt. Tighten the washer-nuts in the order shown.

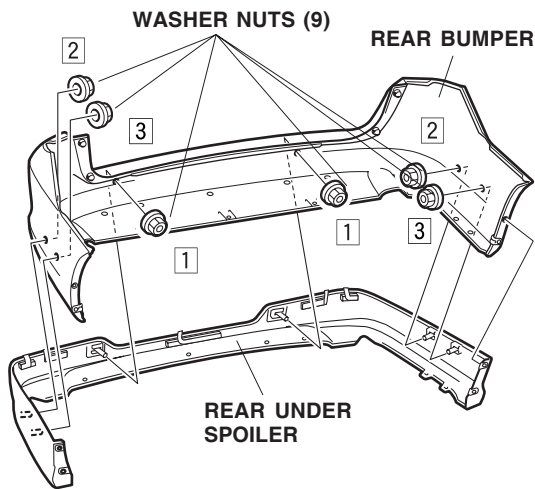

11. Install the five long stepped bolts through the inboard holes in the under spoiler, and install the four short stepped bolts through the outboard holes in the under spoiler. Install a washer-nut on each stepped bolt. Tighten the washer-nuts in the order shown.

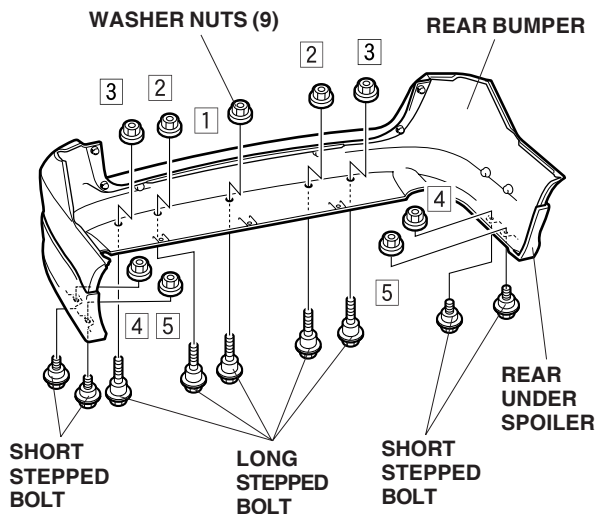

12. While holding light pressure on the under spoiler, carefully remove the adhesive backings from the under spoiler. After attaching, hold the under spoiler firmly against the rear bumper with the palm of your hand for 30 seconds, particularly at the edges.

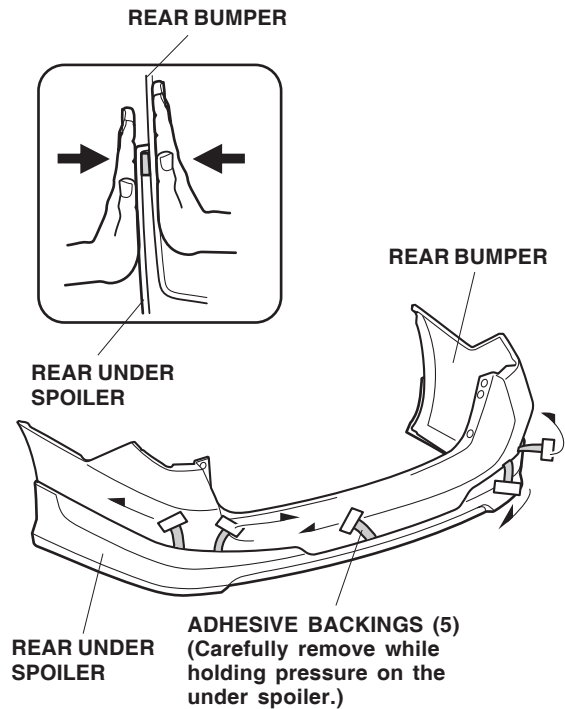

13. Reinstall the rear bumper.

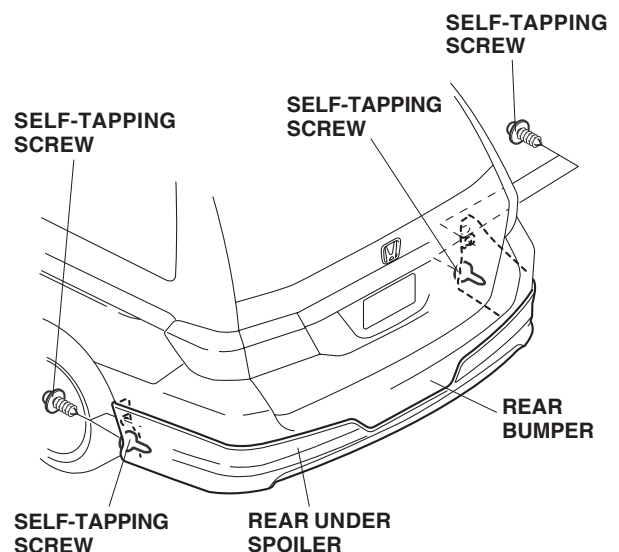

14. Install the self-tapping screws at the fenderwell.

**Give a copy of this page to your customer.**

- When towing the Odyssey, follow the instructions described in the vehicle Owner's Manual.
- When using the rear towing hook, make sure to remove the rear bumper with rear under spoiler. Failure to follow this precaution could damage the vehicle, the rear bumper, and the rear spoiler.

