



INSTALLATION INSTRUCTIONS

Accessory

SPLASH GUARDS
P/N 08P00-SHJ-100

Application

2006 ODYSSEY

Publications No.

All 30408

Issue Date

AUG 2005

PARTS LIST

Right front splash guard

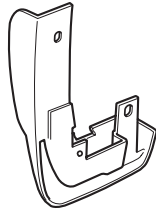

Left front splash guard

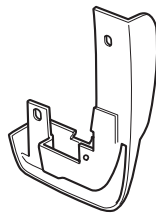

Right rear splash guard

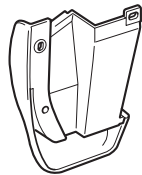

Left rear splash guard

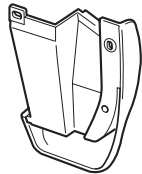

6 Self-tapping screws



2 Spring nuts



2 Round head grommets



2 Square head grommets

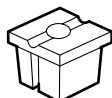

TOOL REQUIRED

Stubby Phillips screwdriver

Diagonal cutters

Pushpin

INSTALLATION

NOTE:

- These instructions show the left splash guards being installed. The same procedure applies to installing the right splash guards.
- Clean and wax the areas to be covered with a high-quality paste wax.

Installing the Front Splash Guards

1. Turn the steering wheel all the way counter-clockwise to provide access to the left front fenderwell.
2. Remove the two self-tapping screws from the left front inner fender.

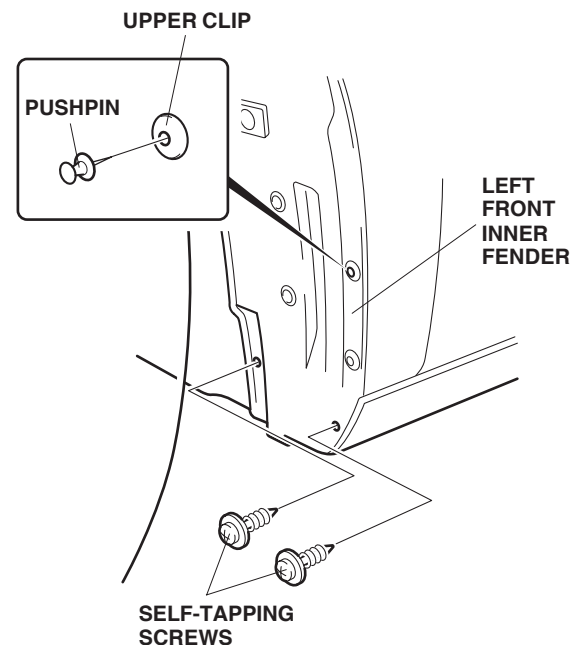

3. Using a pushpin, make a small hole through the center of the upper clip.

- Install the left front splash guard using the two self-tapping screws removed in step 2, and one self-tapping screw supplied with the kit. Do not tighten the self-tapping screws yet.

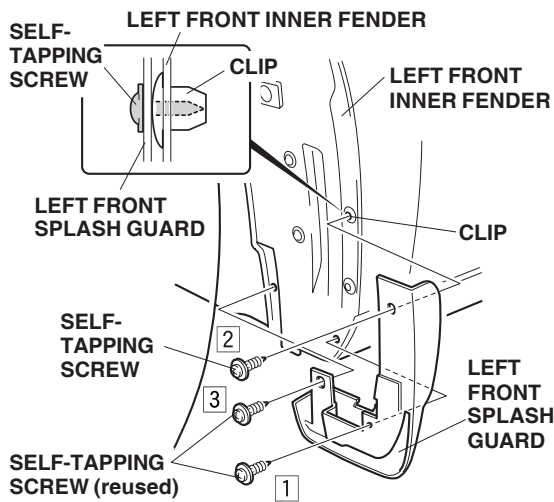

- While holding the left splash guard against the fender, tighten the self-tapping screws in the order shown.
- Turn the steering wheel all the way clockwise and repeat steps 2 through 4 to install the right front splash guard.

Installing the Rear Splash Guard

If the vehicle is not equipped with a rear inner fender, go to step 13; otherwise, continue with step 7.

- Using a stubby screwdriver, remove the left rear inner fender (three self-tapping screws).

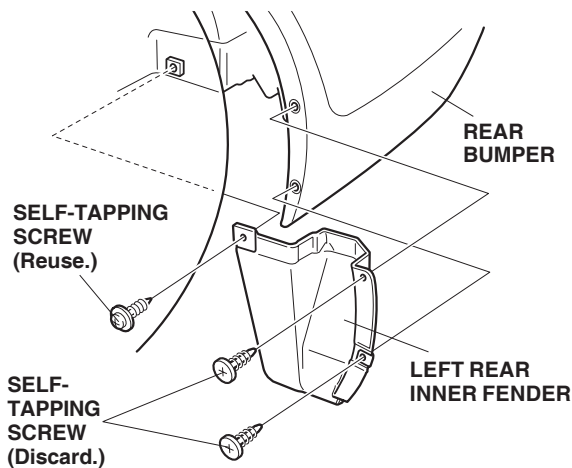

- Using diagonal cutters, cut out the vehicle grommet secured to the vehicle panel.

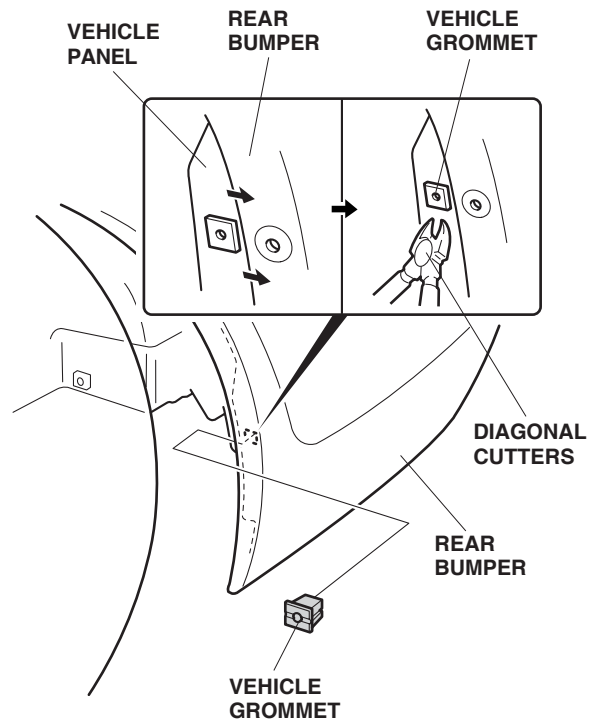

- Install one round head grommet into the hole in the vehicle panel. Slide one spring nut over the lower hole in the rear bumper.

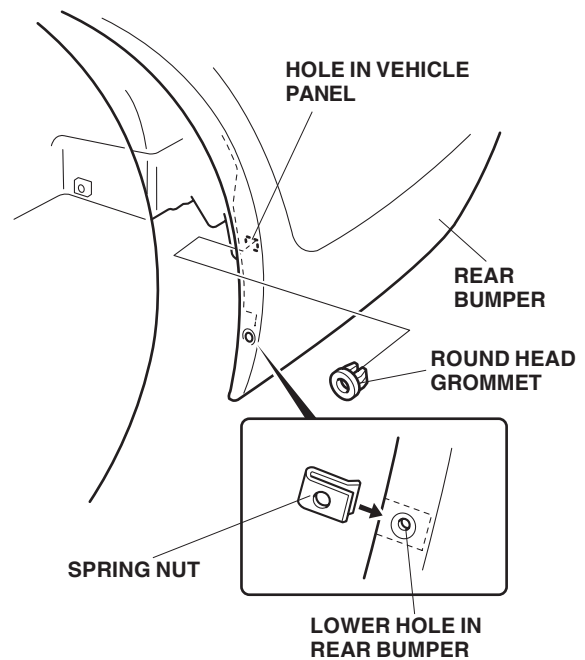

- Position the left rear splash guard on the left rear fenderwell and rear bumper, then loosely install the two self-tapping screws supplied with the kit, and the one self-tapping screw you removed.

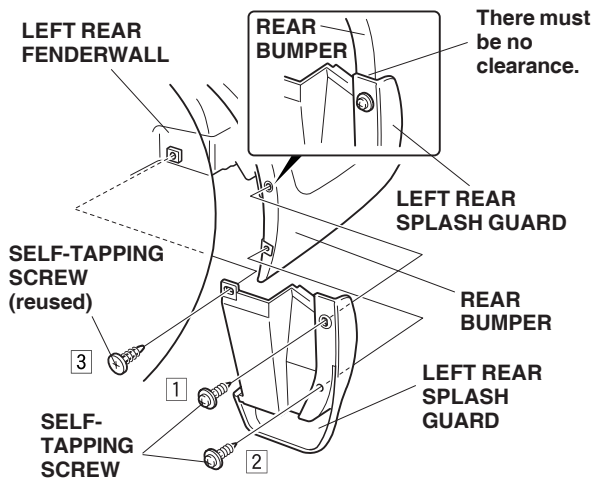

- Hold the left rear splash guard against the fenderwell and check that there is no clearance between the splash guard and rear bumper. Tighten the three self-tapping screws in the sequence shown.
- Repeat steps 7 thru 11 to install the right rear splash guard.

Without an Inner Fender:

- Remove the self-tapping screw from the rear bumper.

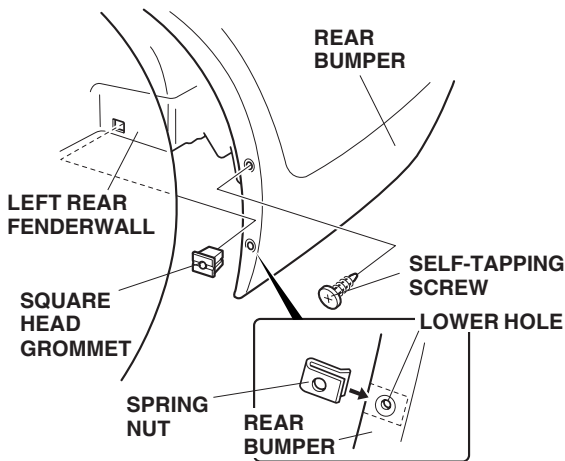

- Install one square head grommet into the hole in the left rear fenderwell. Slide one spring nut over the lower hole in the rear bumper.

- Position the left rear splash guard on the left rear fenderwell and rear bumper, then loosely install the two self-tapping screws supplied with the kit, and one self-tapping screw you removed.

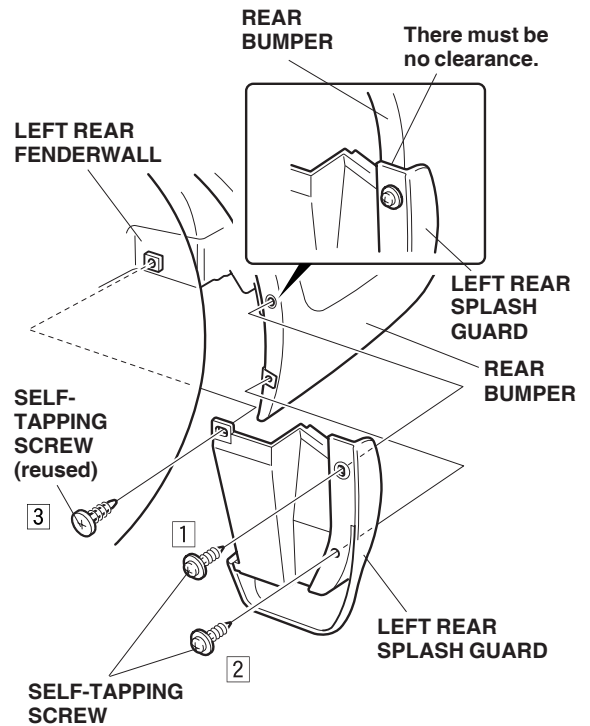

- Hold the left rear splash guard against the fenderwell and check that there is no clearance between the splash guard and rear bumper. Tighten the three self-tapping screws in the sequence shown.
- Repeat steps 13 thru 16 to install the right rear splash guard.