



INSTALLATION INSTRUCTIONS

Accessory
OUTLET PANEL TRIM
 P/N 08Z03-TK6-100C

Application
2009 FIT

Publications No.
All 39874
 Issue Date
AUG 2008

PARTS LIST

Right outlet panel trim

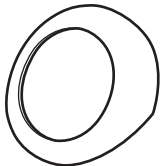

Left outlet panel trim

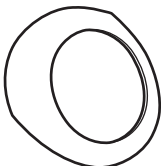

Alcohol swab

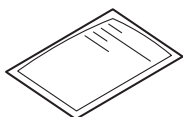

TOOLS AND SUPPLIES REQUIRED

Masking tape

INSTALLATION

NOTE:

- The outlet panel trim kit should only be installed if the ambient air temperature is 15°C (60°F) or above.
- These installation instructions show the right outlet panel trim being installed. The same procedure applies to installing the left outlet panel trim.

Installing the Outlet Panel Trims

1. Remove the three inner adhesive backings from the back of right outlet panel trim.

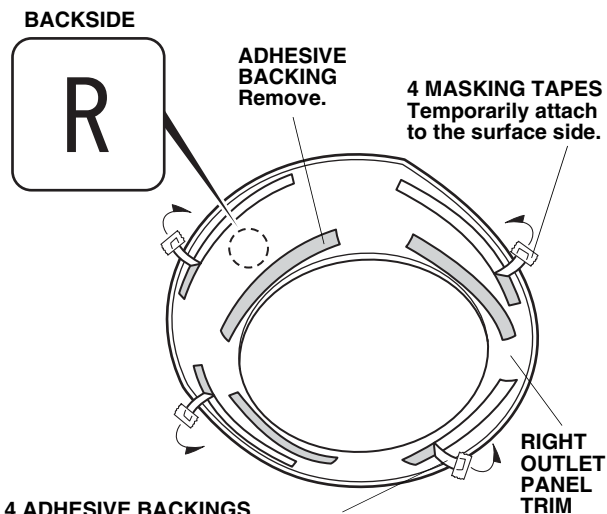

4 ADHESIVE BACKINGS
 Peel back 1½ inches and tape it to the front surface of the outlet panel trim.

2. Peel back 1½ inches of adhesive backing from each of the outer adhesive tapes, and tape the ends to the front surface of the outlet panel trim.
3. Clean the surface where the right outlet panel will attach using the alcohol swab.

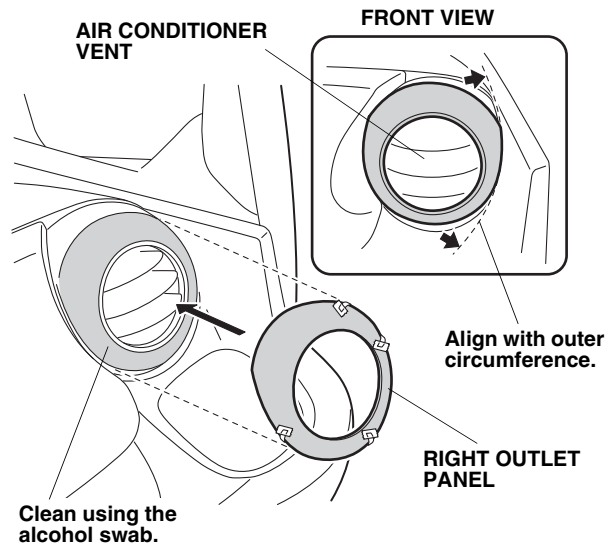

4. Align the right outlet panel trim with the outer circumference of the vent, and attach it to the right outlet panel.

5. While applying light pressure, remove the four adhesive backings from the right outlet panel trim. Press and hold the outlet panel in place with the palm of your hand for 30 seconds.

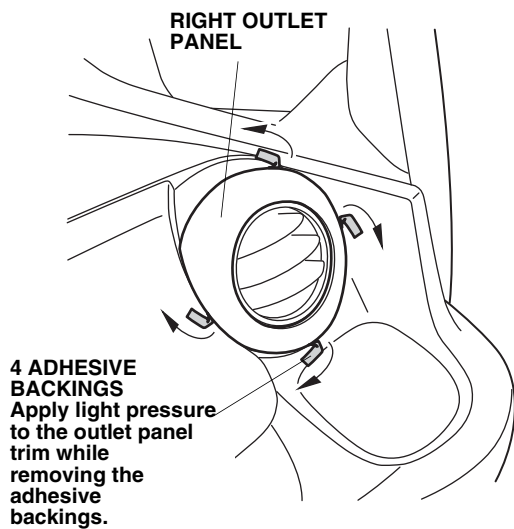

6. Repeat steps 1 thru 5 to install the left outlet panel trim.