



INSTALLATION INSTRUCTIONS

Accessory
REAR UNDER SPOILER

Application
2009 FIT MUGEN

Publications No.
All 40159
Issue Date
APRIL 2009

NOTE: The rear under spoiler cannot be installed on a vehicle equipped with splash guards.

PARTS LIST

Rear under spoiler

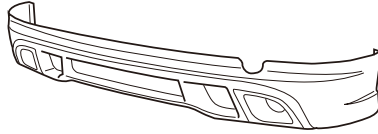

4 Washer bolts (6 x 15 mm)



6 Rubber washers



6 Flange nuts



4 Self-tapping screws



4 Spring nuts



Right exhaust finisher



Left exhaust finisher



Template A

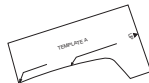

Template B

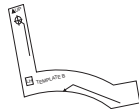

Template C

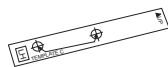

Template D



TOOLS REQUIRED

- Phillips screwdriver
- Flat-tip screwdriver
- Hex wrench
- Drill
- 5 mm Allen wrench
- 3 mm, 6 mm and 10 mm Drill bits
- Clip remover
- Center punch
- Pushpin
- Airsaw
- Utility knife
- Felt-tip pen
- Scale
- Masking tape
- Isopropyl alcohol
- Shop towel
- Eye protection
- Blanket

INSTALLATION

Customer Information: The information in this installation instruction is intended for use only by skilled technicians who have the proper tools, equipment, and training to correctly and safely add equipment to your vehicle. These procedures should not be attempted by “do-it-yourselfers.”

NOTE:

- Allow the exhaust pipe to cool down before installing this accessory.
- Be careful not to damage the rear bumper and the paint finish.
- This rear under spoiler kit should be installed only if the ambient temperature is 60°F (15°) or above.
- To allow the adhesive to cure, do not wash the vehicle for 24 hours.

1. Remove the stock exhaust tip (one bolt). Set the exhaust tip aside; it will not be reused.
2. With the vehicle on a rack, remove the rear bumper.
 - At each rear fenderwell, remove the two self-tapping screws.
 - Under the bumper remove two additional self-tapping screws, and 5 clips (4 long clips and one short clip).

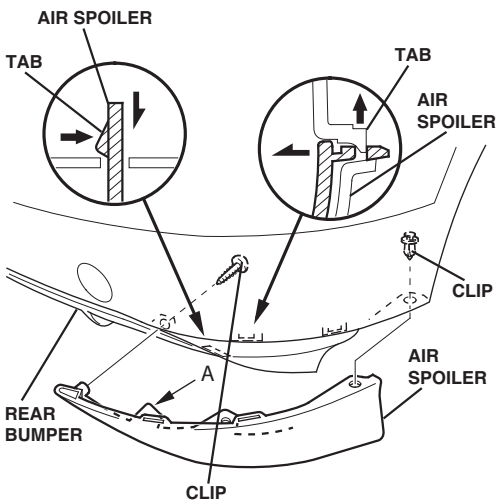

- At the rear hatch opening, remove the four bolts (two on each side).
- On each side, push down on the tabs to release the bottom hooks, then pull out on each side of the bumper to release the hooks.

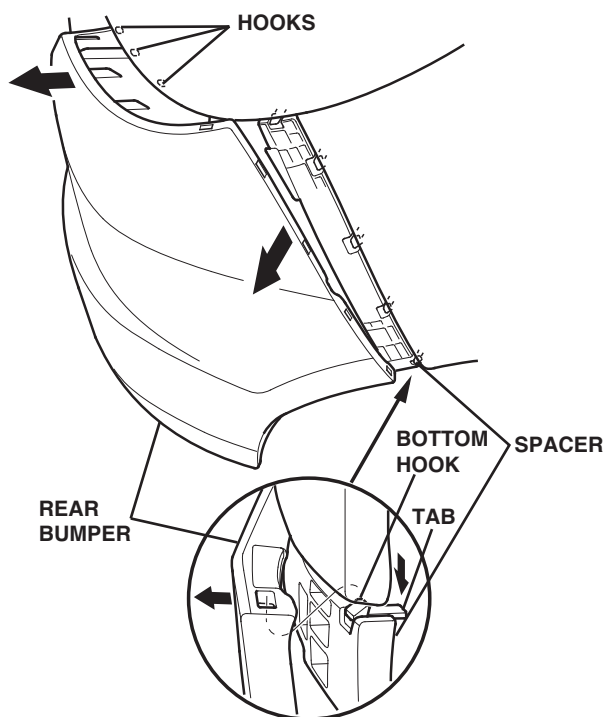

- With the help of an assistant, pull the rear bumper out to release the top two hooks.
- Set the bumper on a blanket.

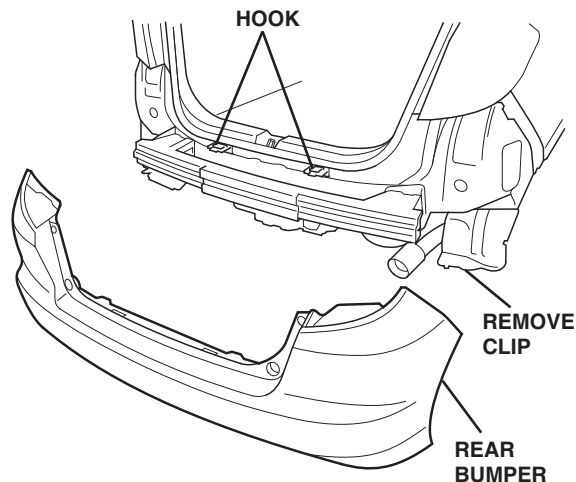

3. Remove the rear bumper air spoilers (one screw, one clip and three tabs).

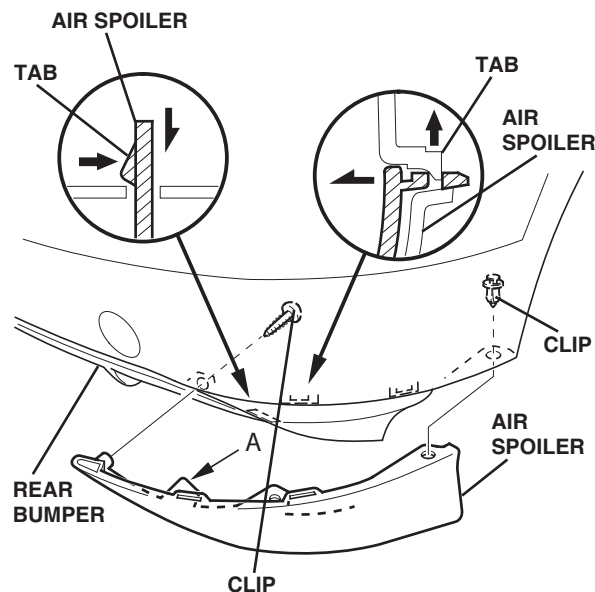

- Place template A on the rear bumper as shown, and mark the height of the rear under spoiler with a white marker.

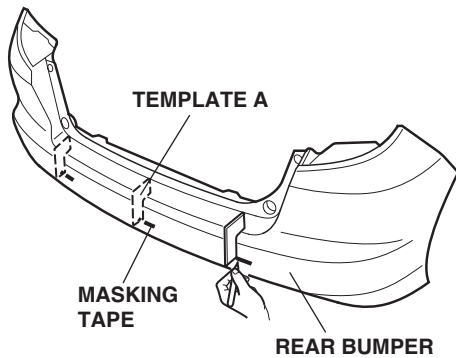

- On the bottom of the rear bumper, place template B on the left side of the bumper. Using a pushpin, pierce the bumper as indicated on the template.

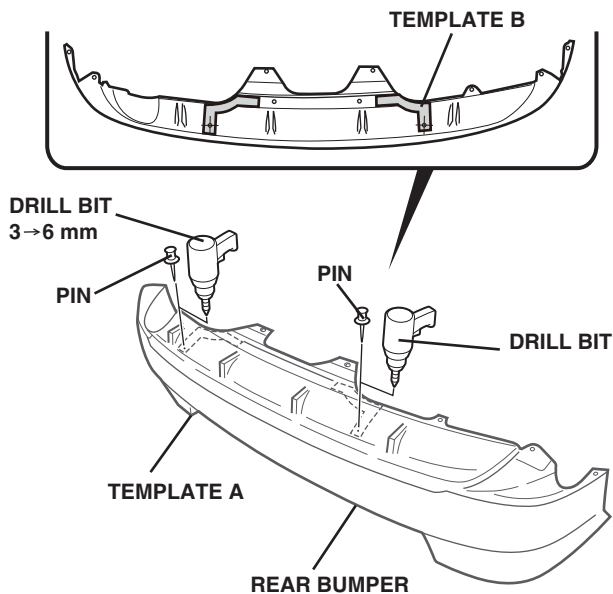

- Turn the template over and mark the right side of the bumper the same way.
- While wearing eye protection, drill the pierced marks on the bumper 6 mm.
 - First drill with a 3 mm drill bit, and finish with a 6 mm drill bit.
 - Remove all burrs from each drilled hole.

- Place template D on the bottom left side of the rear bumper and tape it in position. Using a felt-tip pen, mark around the template. Remove the template.

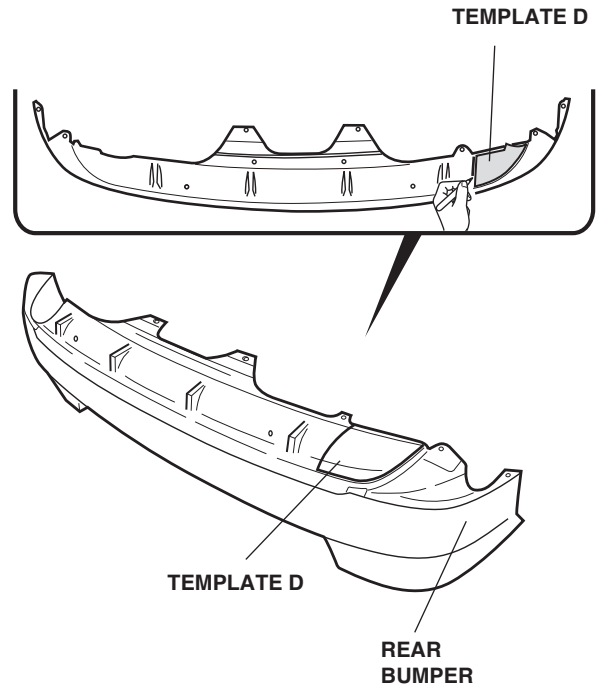

- Using an air saw, cut the rear bumper along the line. Use a file to remove any burrs from the edges.

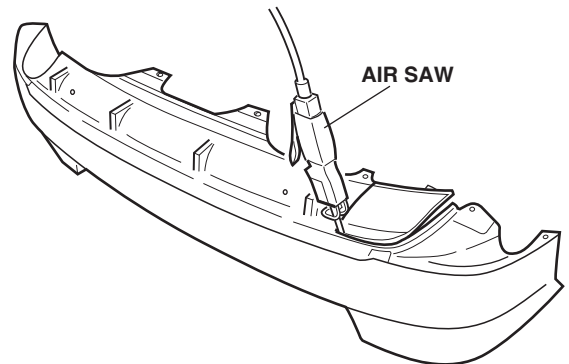

- Turn the template over, and mark and cut the other side of the rear bumper the same way.

11. Place template C on the left rear fenderwell and tape it in place. Using a pushpin, pierce the bumper in two places as indicated on the template.

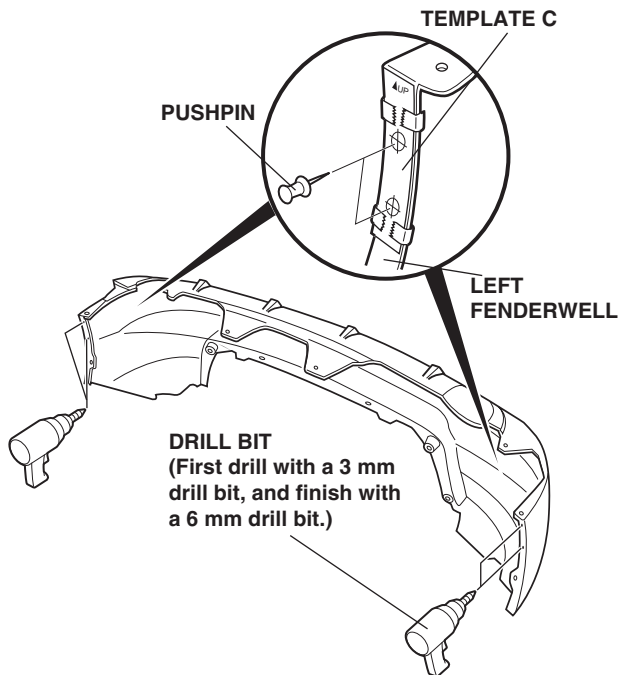

12. While wearing eye protection, drill the pierced marks on the bumper.
- First drill with a 3 mm drill bit, and finish with a 6 mm drill bit.
 - Remove all burrs from each drilled hole.
 - Install one spring nut over each drilled hole.
13. Turn the template over and repeat steps 11 and 12 to mark and drill the right fenderwell.
14. Reinstall the rear bumper, but do not install the outboard clips yet.

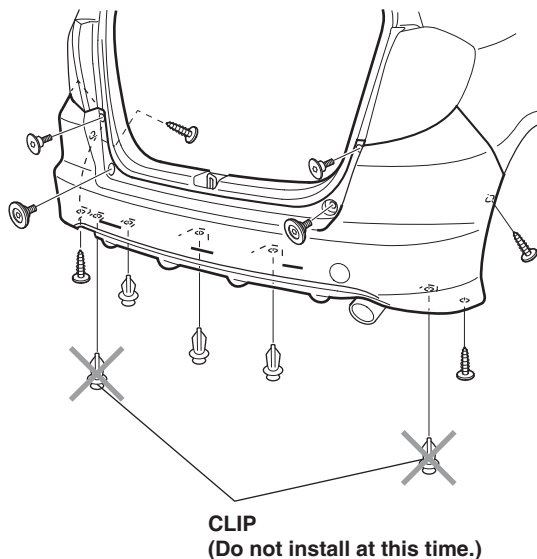

15. Using isopropyl alcohol on a shop towel, clean the rear bumper where the rear under spoiler will attach. Do not erase the white mark made in step 4. Allow the alcohol to dry.

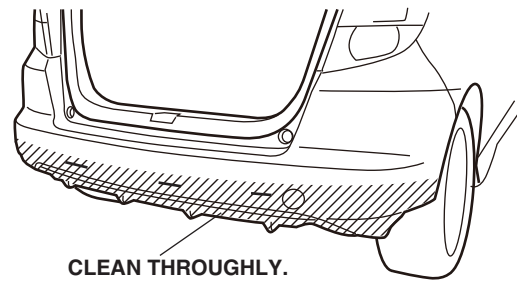

16. Attach a strip of masking tape to the end of each adhesive backing, and peel back 1½ to 2 inches of adhesive backing. Fold the ends back, and tape them to the front of the rear under spoiler.

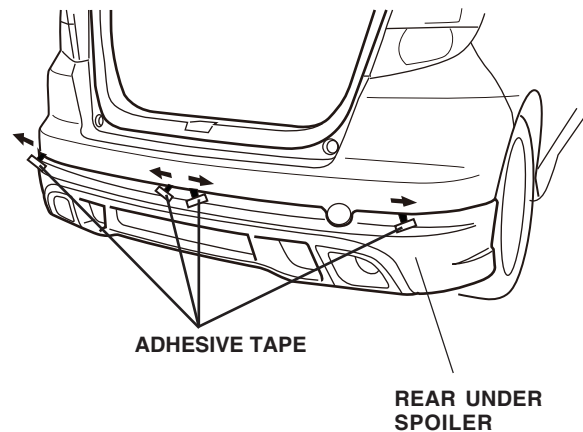

17. With the help of an assistant, place the rear under spoiler on the rear bumper. Bring the edge of the rear under spoiler up to the white marks made in step 4, and align the cutout in the under spoiler with the tow hook access cover.

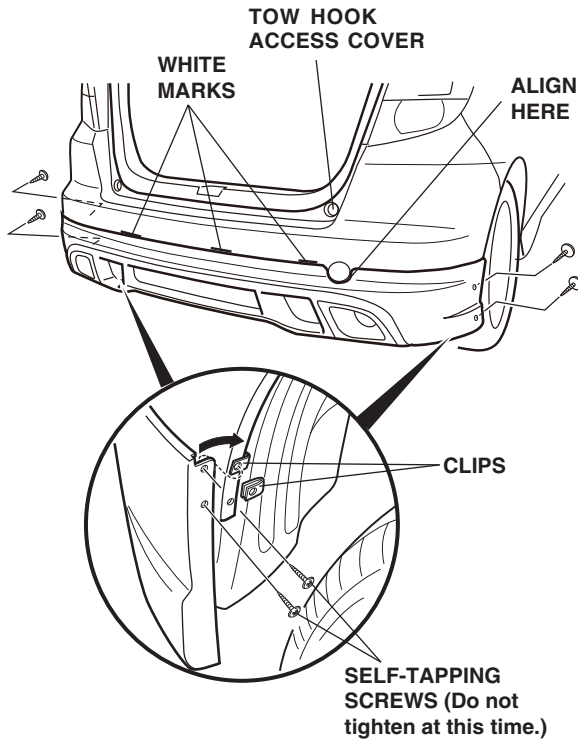

18. Install the four self-tapping screws, and the four clips (two on each side). Do not tighten the self-tapping screws at this time.
19. When you are satisfied that the rear under spoiler is centered around the tow hook access cover, and is up to the white line, slowly and carefully remove the adhesive tape. Start in the center and work outward around the bumper.

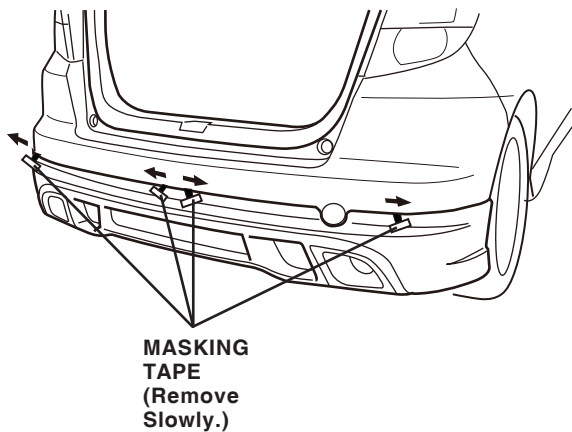

20. Using the palm of your hand, hold the spoiler firmly against the bumper for 30 seconds. Using a rubber roller, apply firm pressure while rolling to set the adhesive.

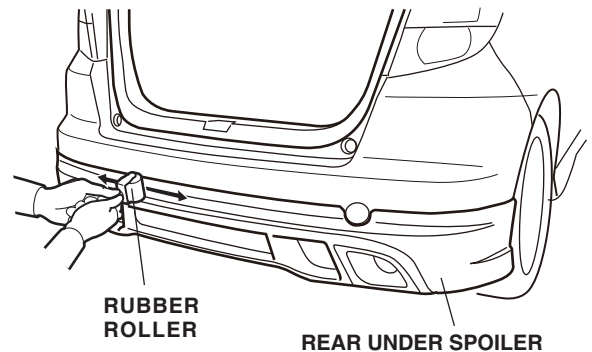

21. Tighten the self-tapping screws installed in step 18.
22. Under the rear spoiler, locate the two tabs protruding from the under spoiler. Using a pushpin, pierce the center of each hole.

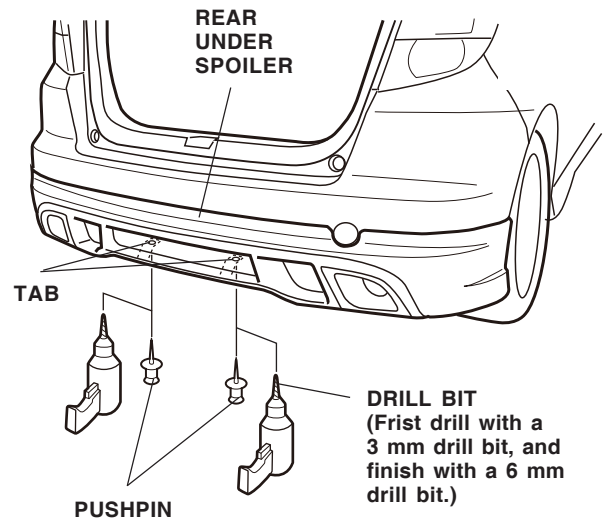

23. While wearing eye protection, drill the pierced marks.
- First drill with the 3 mm drill bit, and finish with a 6 mm drill bit.
 - Remove all burrs from each drilled hole.

24. Under the bumper, install four flange bolts through each hole and install the flange nuts. Tighten the nuts and bolts securely.

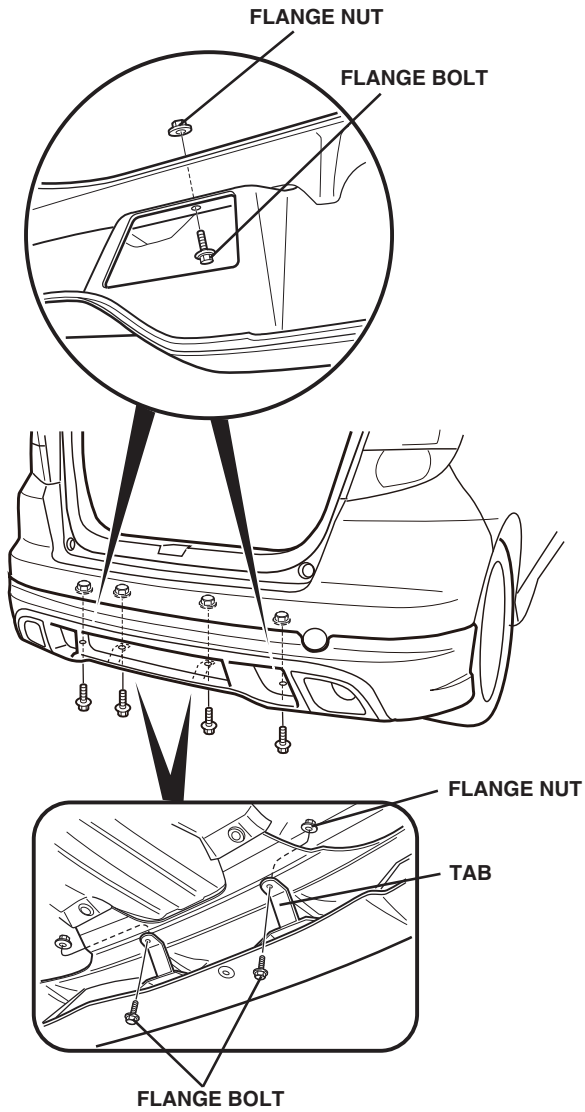

25. Install the outboard bumper clips through the under spoiler brackets. Be sure to install the rubber washer between the bracket and the splash shield on the driver's side of the vehicle.

