



INSTALLATION INSTRUCTIONS

Accessory
BACK-UP SENSORS

Application
2012 CROSSTOUR

Publications No.
All 46173
Issue Date
JULY 2011

PARTS LIST

**Rear Back-up Sensor Attachment Kit
P/N 08V67-TP6-100A**

Control unit

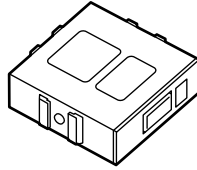

Buzzer

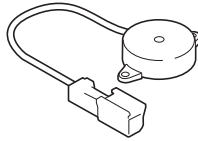

Switch

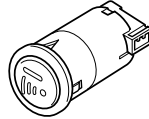

Back-up sensor harness

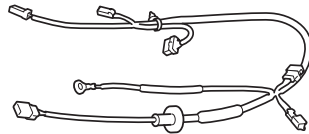

Back-up sensor subharness

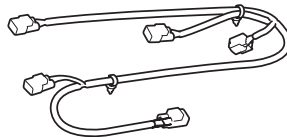

Control unit bracket

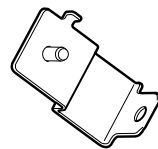

Wire tie with clip A

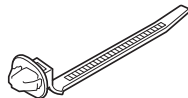

5 Aluminum tapes



7 Wire ties

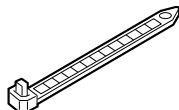

Fuse label

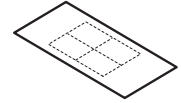

Wire tie with clip B

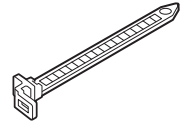

2 Sensor clips (Black)

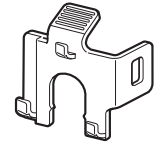

2 Sensor clips (White)

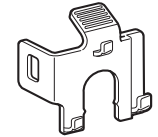

Switch bracket

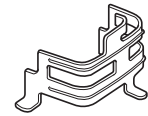

Flange nut



Small wire tie

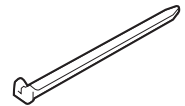

Ground bolt

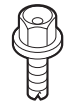

2 Urethane tapes



Subbracket



Accessory User's Information Manual

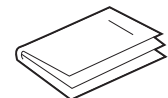

Back-up Sensor Kit

Right corner sensor

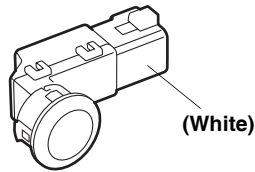

Left corner sensor

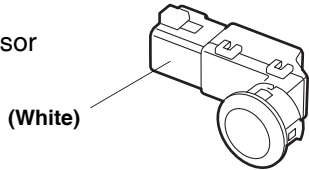

Right center sensor

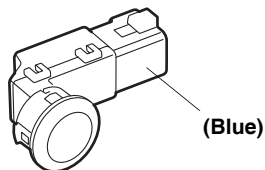

Left center sensor

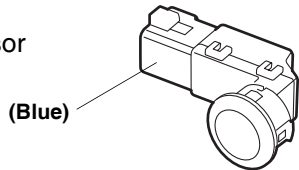

TOOLS AND SUPPLIES REQUIRED

- Phillips screwdriver
- Flat-tip screwdriver
- Ratchet
- 10 mm Socket
- Isopropyl alcohol
- Shop towel
- Pushpin
- Drill
- 3 mm Drill bit
- 24 mm and 26 mm Hole saws
- Tape measure
- Blanket
- Eye protection (safety goggles, face shield, etc.)
- 10 mm Combination wrench
- File
- Scissors
- Clip remover
- Plastic Trim Tool (T/N SILTRIMTL10)

Illustration of the Back-up Sensors Installed on the Vehicle

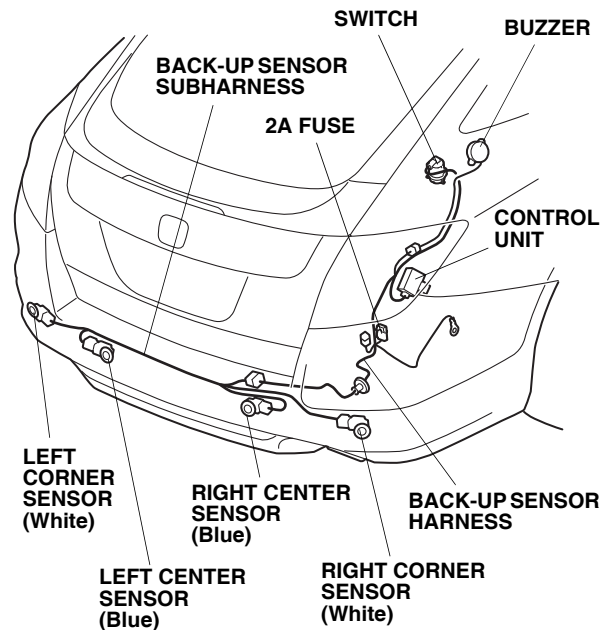

INSTALLATION

Customer Information: The information in this installation instruction is intended for use only by skilled technicians who have the proper tools, equipment, and training to correctly and safely add equipment to your vehicle. These procedures should not be attempted by “do-it-yourselfers.”

NOTE: If you are also installing a trailer hitch, install the back-up sensor kit first.

1. Make sure you have the anti-theft codes for the audio and navigation system (if equipped), then write down the radio station presets.
2. Disconnect the negative cable from the battery.

3. If equipped, remove the rear shelf.

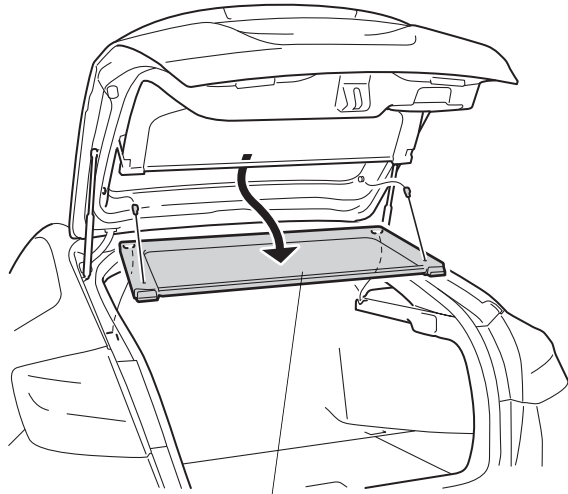

REAR SHELF
If equipped.

4. Remove the cargo floor rear lid, cargo floor left lid, and cargo floor right lid.

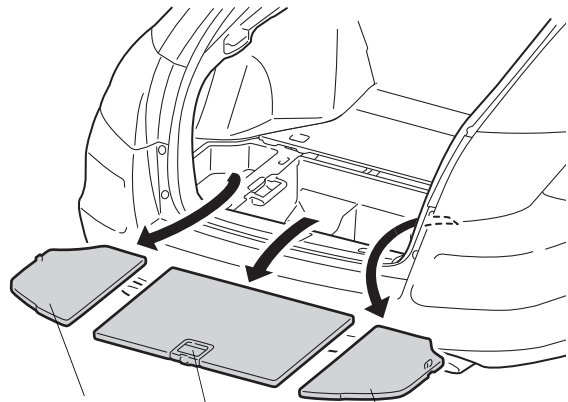

**CARGO FLOOR
LEFT LID**

**CARGO FLOOR
REAR LID**

**CARGO FLOOR
RIGHT LID**

5. Using a plastic trim tool, pry open the screw cover. Remove the tie down hook (one screw). Remove the other tie down hook the same way.

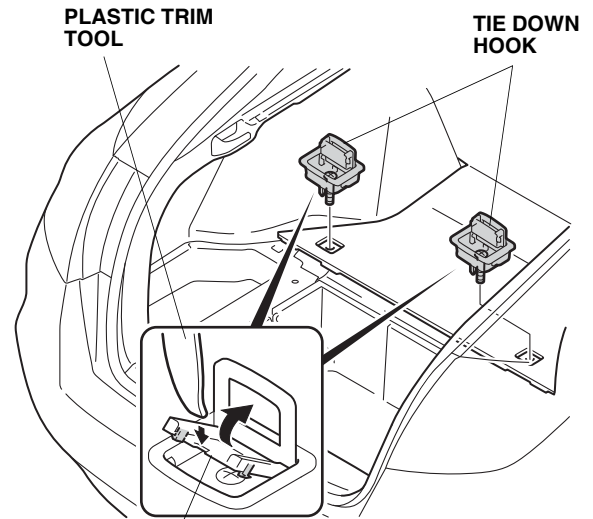

**PLASTIC TRIM
TOOL**

**TIE DOWN
HOOK**

SCREW COVER
Pry open.

6. Fold down the rear seat back. Remove the cargo floor front lid (three clips).

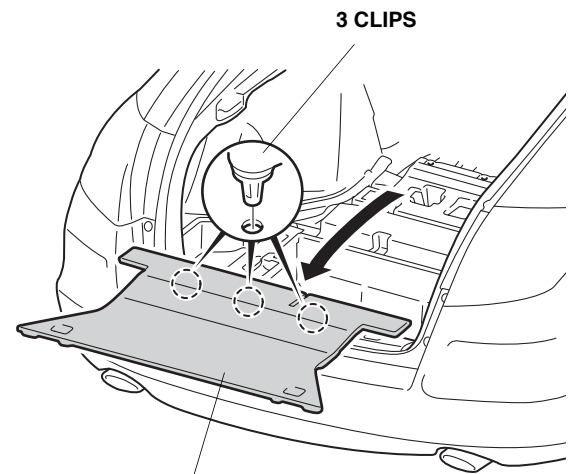

3 CLIPS

**CARGO FLOOR
FRONT LID**

7. Remove the cargo box.

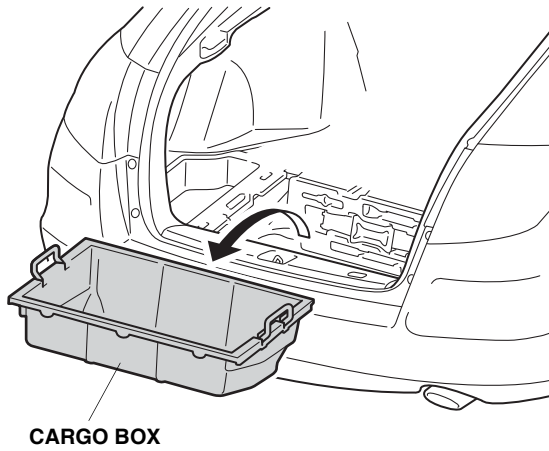

8. Pry open the bolt cover, and remove the right cargo tray bolt.

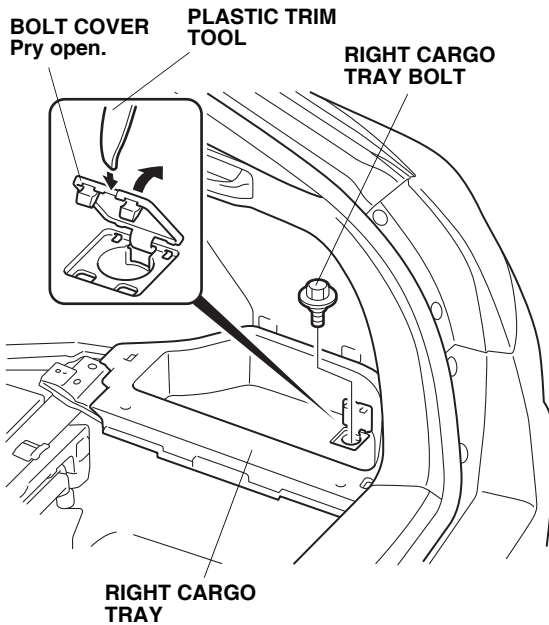

9. Remove the right cargo tray (two clips).

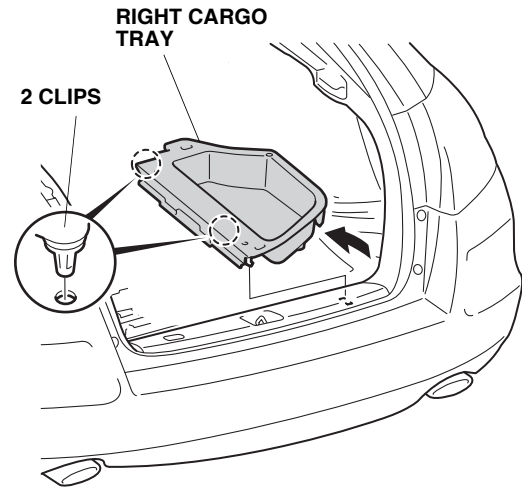

10. Pull away the weatherstrip in the area shown. Remove the rear trim panel (two push clips, four clips, and four tabs).

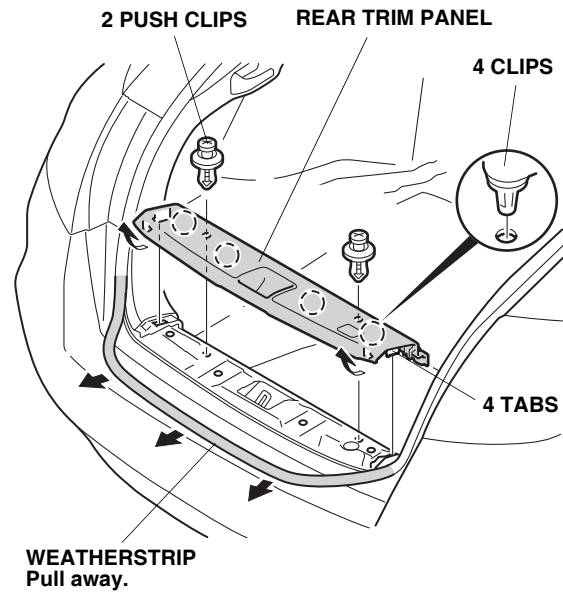

11. Remove the rear seat cushion bolt(s).

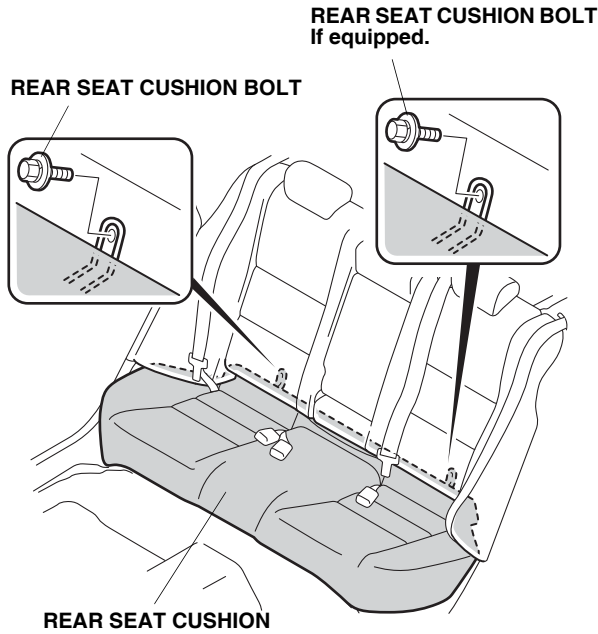

12. Pull out on the two knobs to release the two hooks, and remove the rear seat cushion.

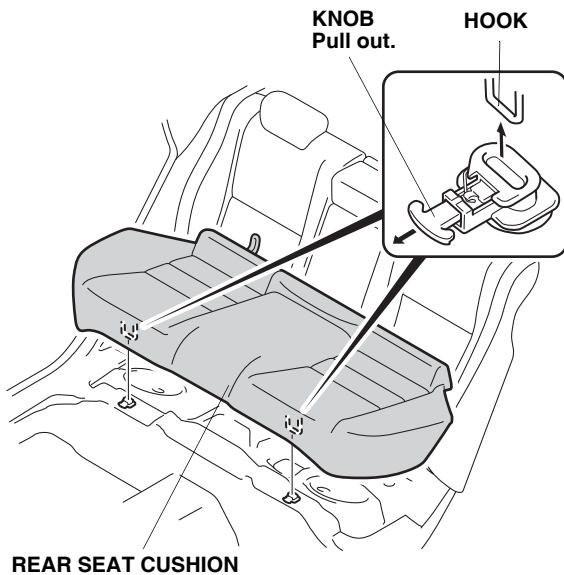

13. Remove the right rear seat side bolster (one bolt and two hooks).

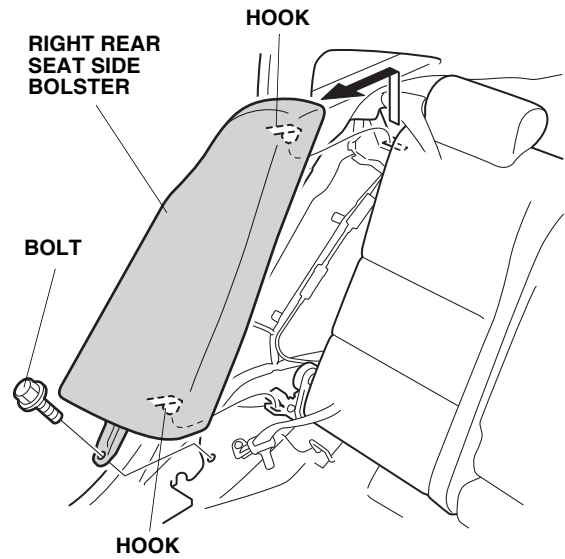

14. Fold down the right rear seat back. Remove the one clip from the right rear side liner.

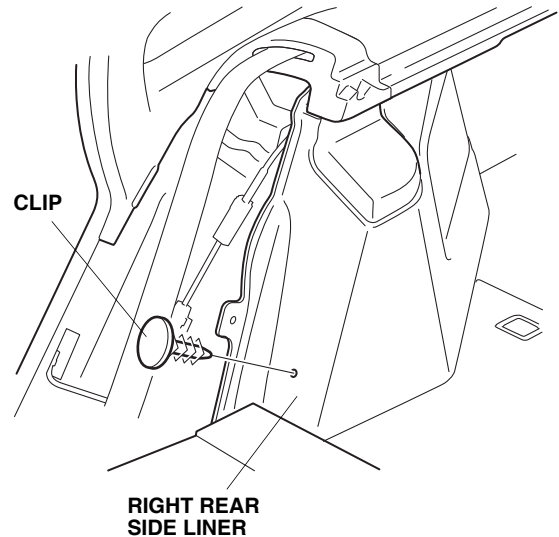

15. Remove the right cover (three clips and four tabs).

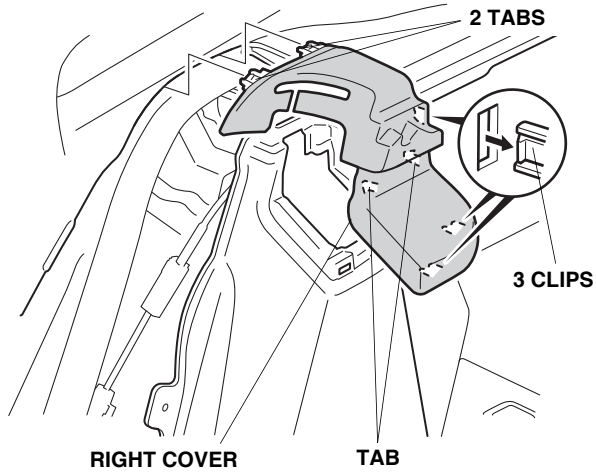

16. Using a plastic trim tool, remove the tie down hook cover. Remove the tie down hook (one bolt).

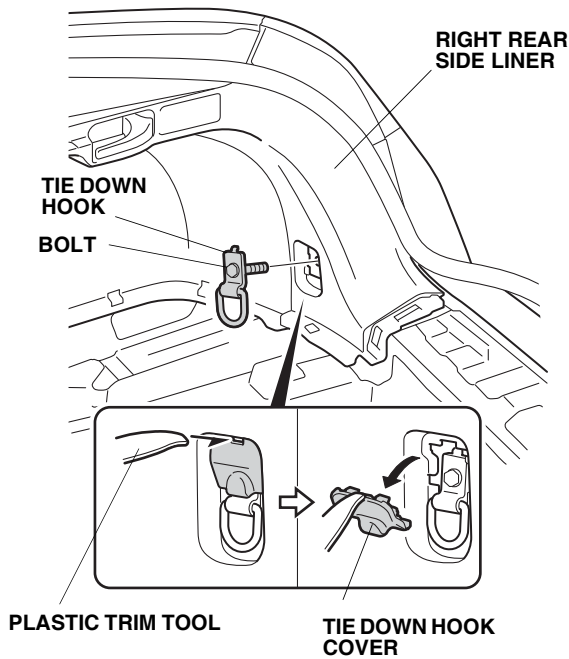

17. Using a plastic trim tool, remove the right side liner plastic cover. Remove the two screws under the cover.

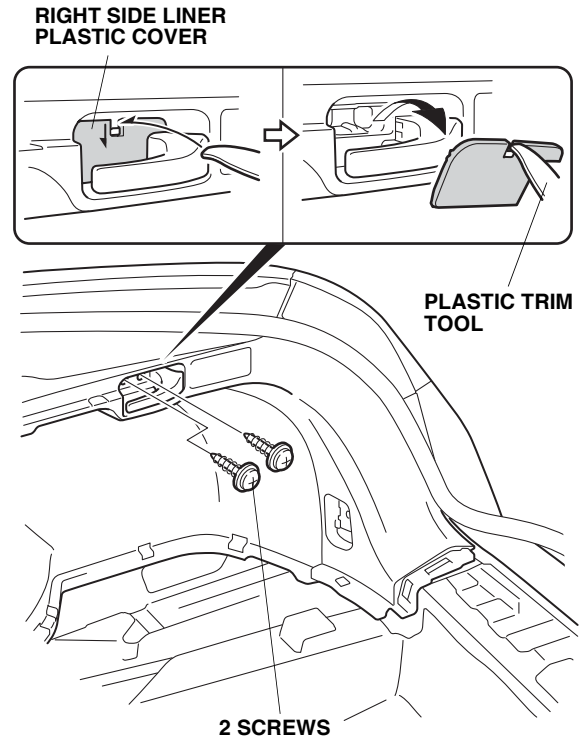

18. Pull away the weatherstrip around the right rear side liner. Remove the six clips and unplug the vehicle connectors, then pull the right rear side liner out of the way.

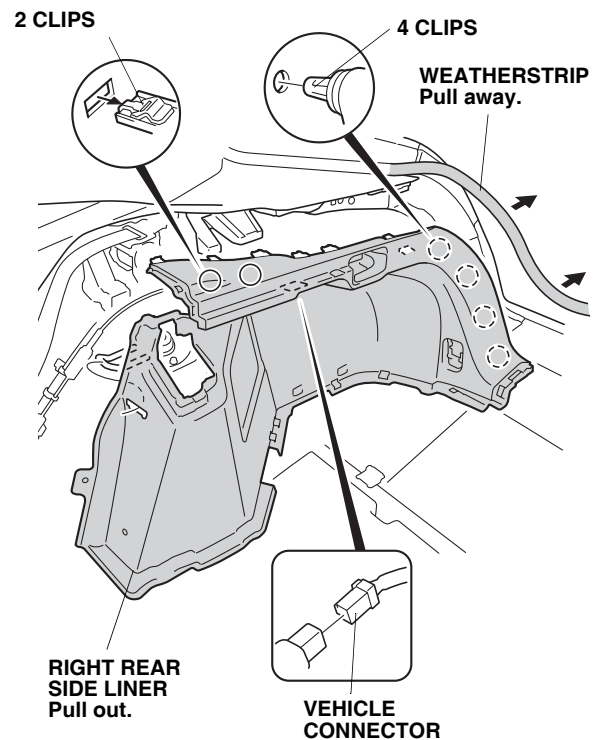

19. Pull away the weatherstrip and door seal from around the right rear quarter pillar lining. Remove the right rear quarter pillar lining (one self-tapping screw and seven clips). Be careful not to crease the headliner.

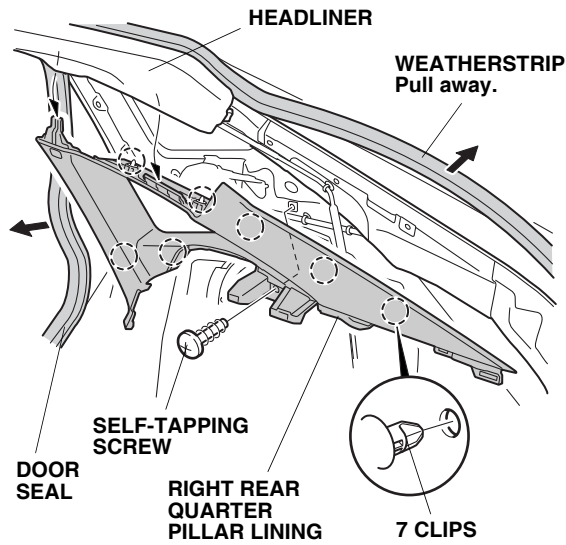

20. Remove the rear bumper:

- Remove the four bolt covers, four bolts, and two clips.

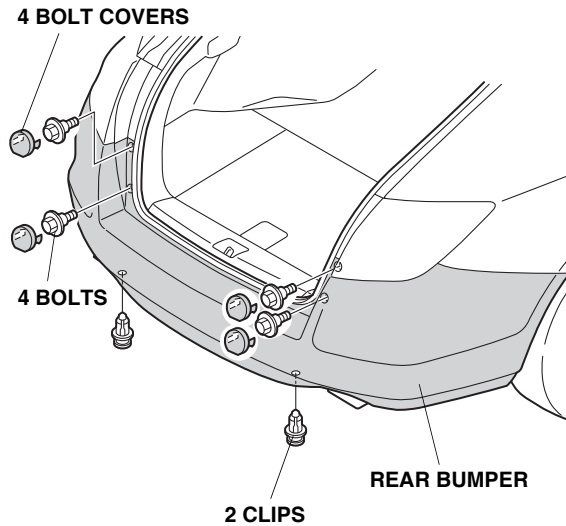

- On each side, remove the three self-tapping screws at the fenderwell.

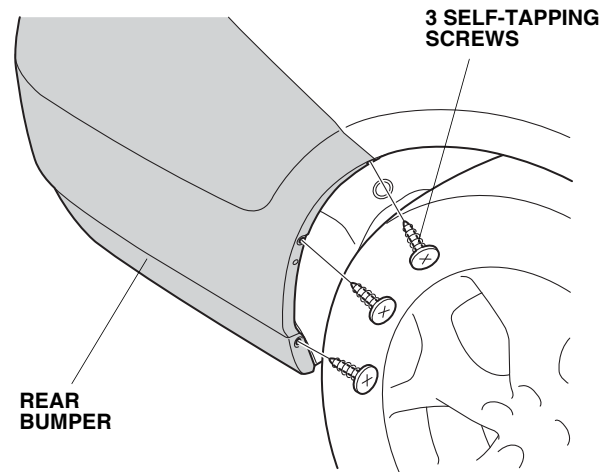

- Under the rear bumper, remove the two clips and one self-tapping screw on each side.

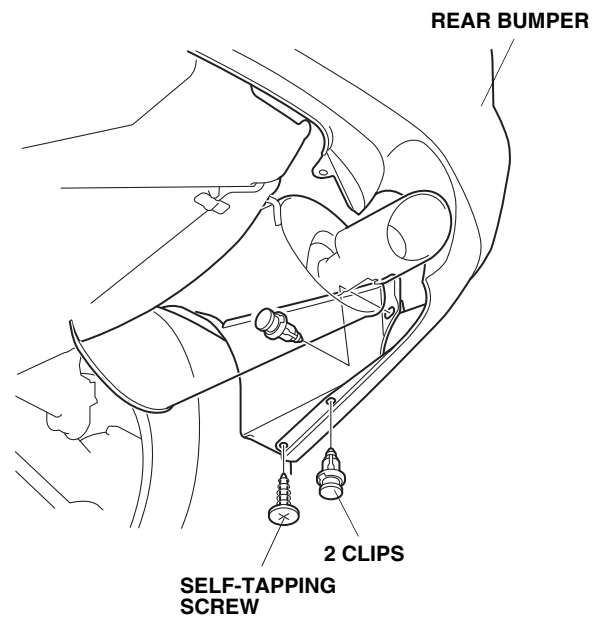

- With the help of an assistant, remove the rear bumper. Place the rear bumper on a blanket to prevent damage.

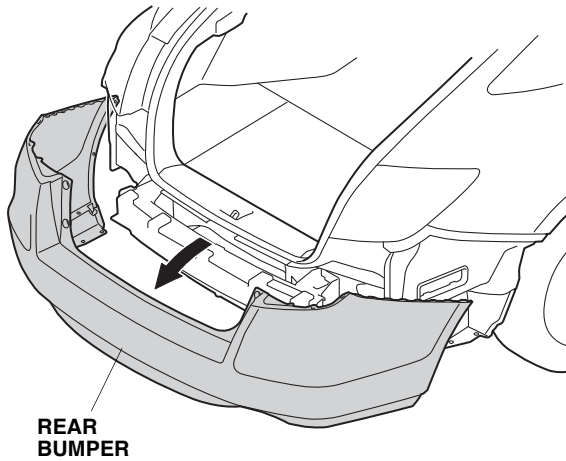

Installing the Control Unit

21. Using scissors, cut two urethane tapes to the measurements shown.

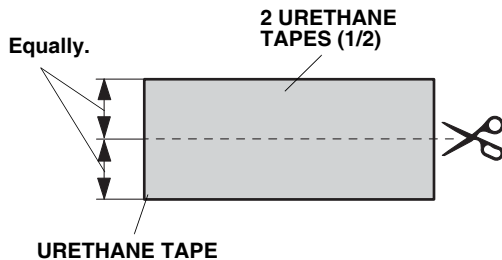
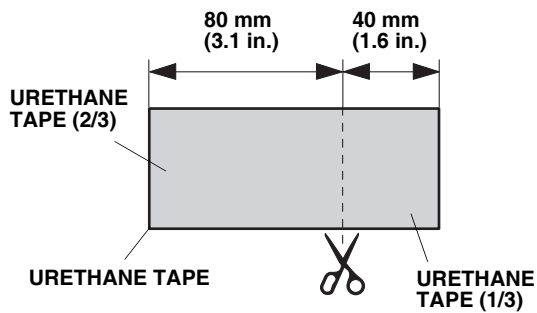

22. Install the control unit bracket and subbracket to the control unit.

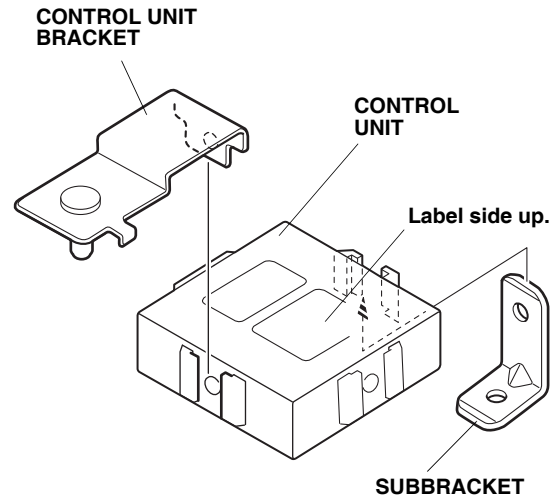

23. Using isopropyl alcohol on a shop towel, clean the area where the urethane tape will attach. Attach the 80 mm piece of urethane tape to the control unit.

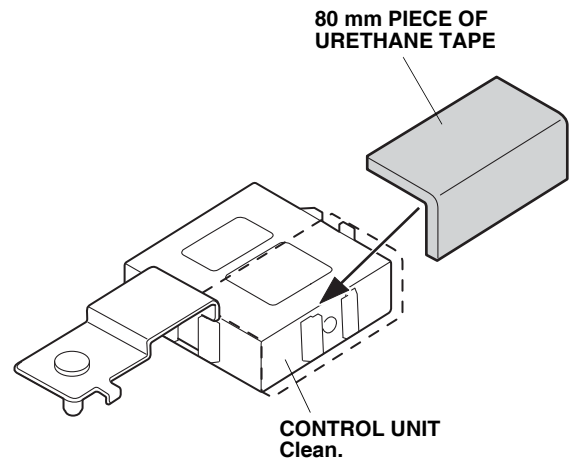

24. Install the control unit bracket through the hole in the vehicle panel and install the flange nut.

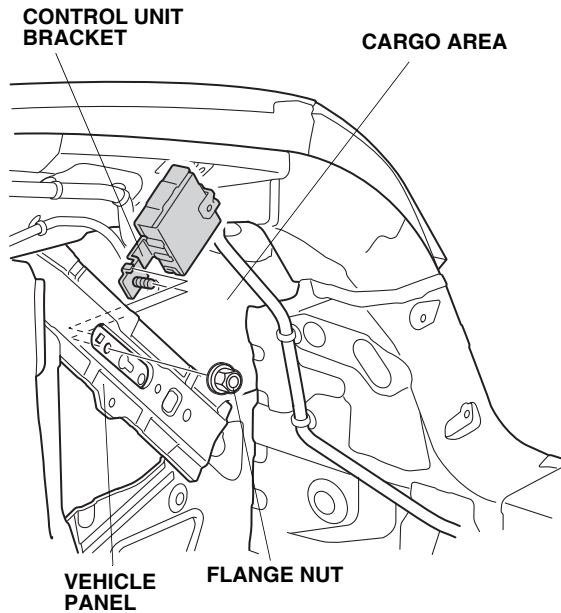

25. Using isopropyl alcohol on a shop towel, clean the area where the fuse label will attach. Attach the 2A fuse label to the fuse case on the back-up sensor harness.

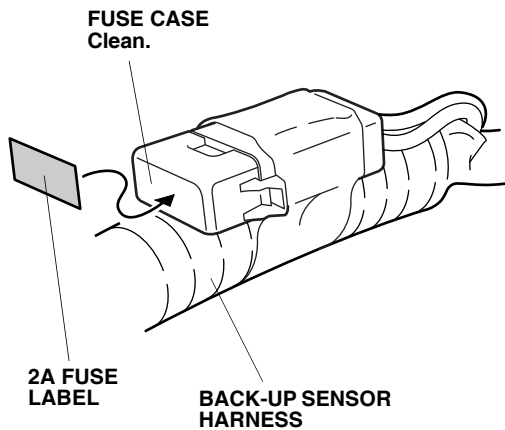

26. Wrap the 1/2 piece of urethane tape around the back-up sensor harness 2-pin connector.

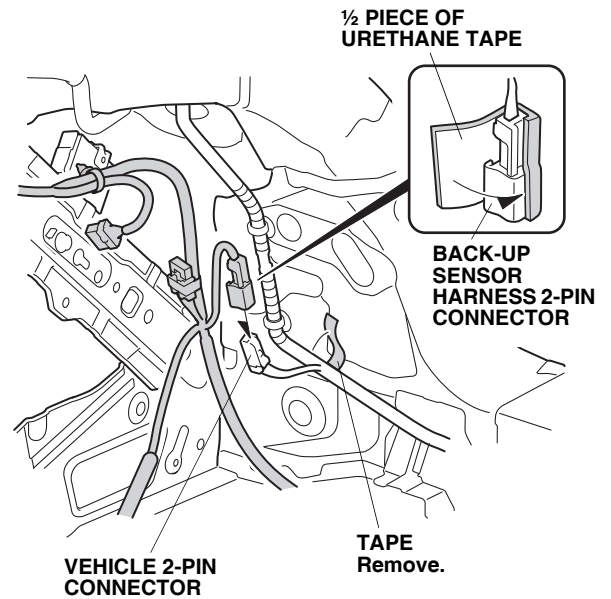

27. Remove the tape that secures the vehicle 2-pin connector, then plug the back-up sensor harness 2-pin connector to the vehicle 2-pin connector.
28. Using the wire tie with clip A, secure the back-up sensor harness to the panel hole at the green tape.
- NOTE: If the panel hole is already being used, secure the back-up sensor harness to the vehicle harness.

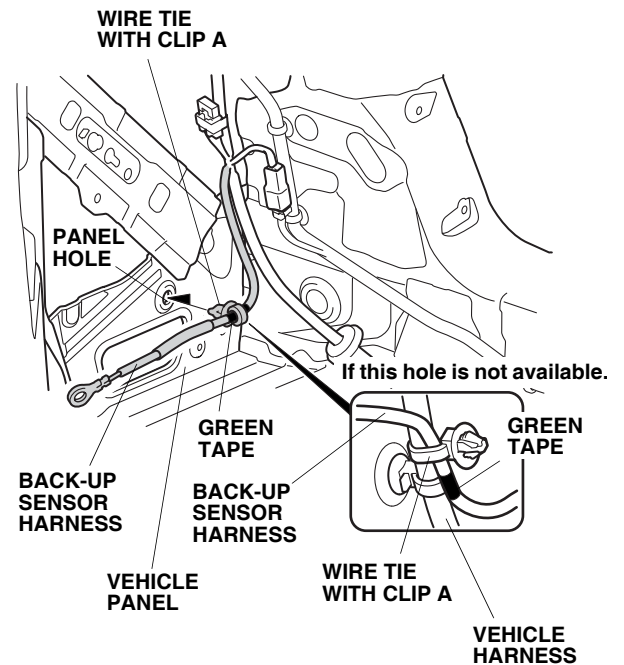

29. Using the ground bolt provided, attach the back-up sensor harness ground terminal to the vehicle panel.
- NOTE:** If the vehicle is equipped with a navigation unit, remove the bolt and attach the back-up sensor harness ground terminal using the ground bolt.

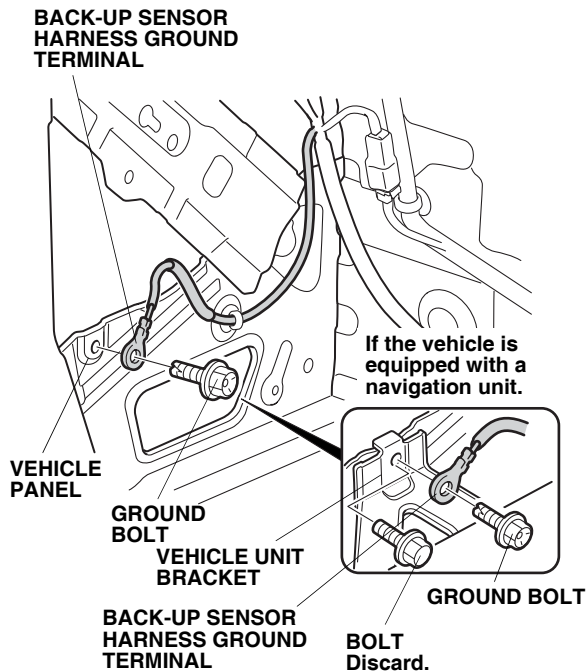

30. Plug the back-up sensor harness 14-pin connector into the control unit as shown.

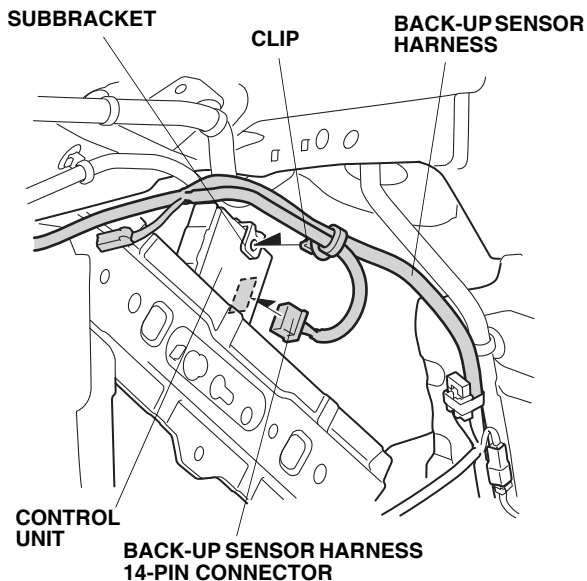

31. Insert the clip on the back-up sensor harness into the hole in the subbracket.

32. Wrap the other ½ piece of urethane tape around the buzzer harness as shown.

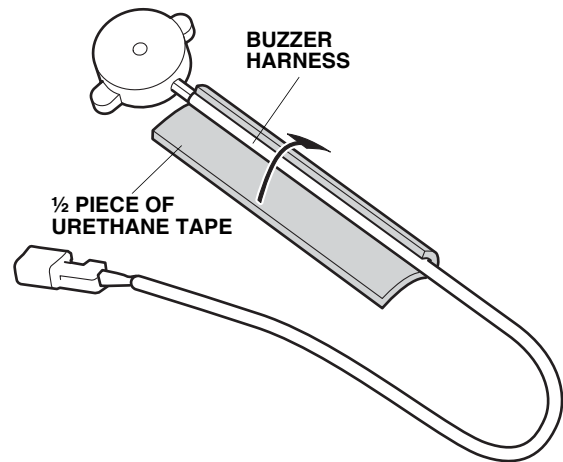

33. Using isopropyl alcohol on a shop towel, clean the area where the buzzer will attach. Remove the adhesive backing and attach the buzzer to the vehicle panel in the area shown.

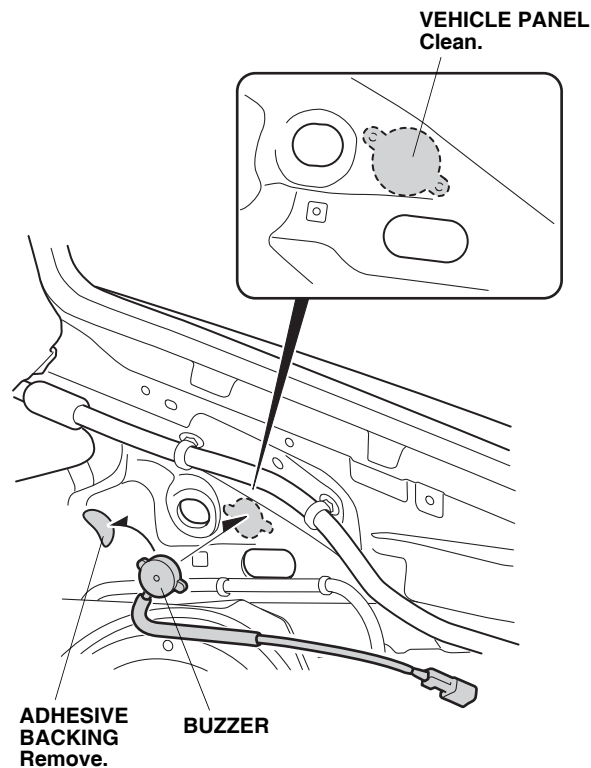

34. Wrap the 40 mm piece of urethane tape around the buzzer connector, then plug the buzzer connector into the back-up sensor harness 2-pin connector.

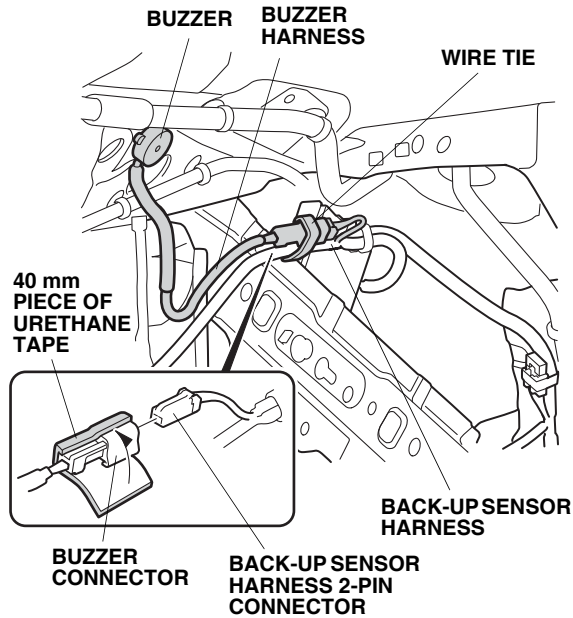

35. Using one wire tie, secure the buzzer connector to the back-up sensor harness.
36. Using one wire tie, secure the back-up sensor harness and the buzzer harness to the vehicle panel.

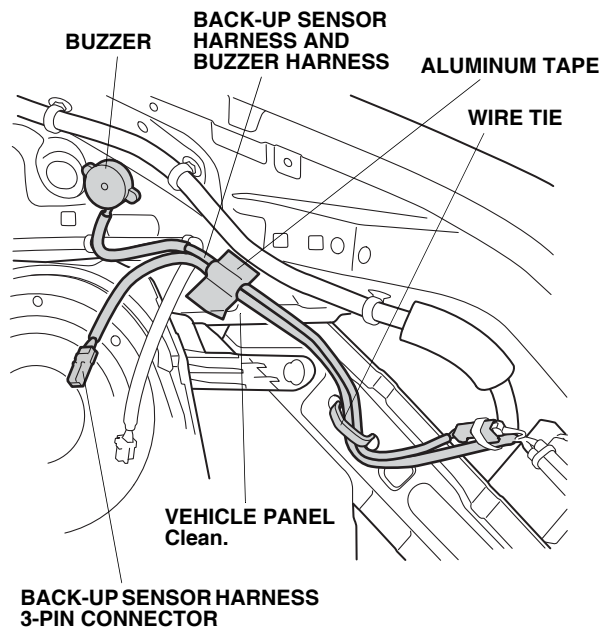

37. Using isopropyl alcohol on a shop towel, clean the area where the aluminum tape will attach. Using one aluminum tape, secure the back-up sensor harness and the buzzer harness to the vehicle panel.

38. Using one wire tie, secure the back-up sensor harness and the buzzer harness to the vehicle harness.

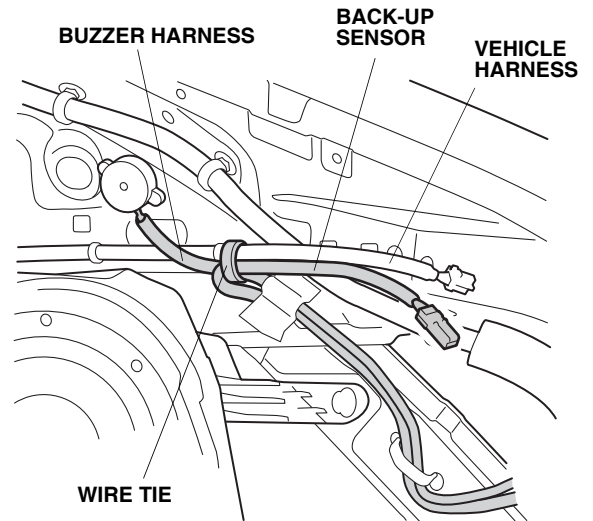

39. At the rear of the vehicle, locate and remove the grommet. Route the back-up sensor harness through the panel hole. Seat the back-up sensor harness grommet into the vehicle panel.

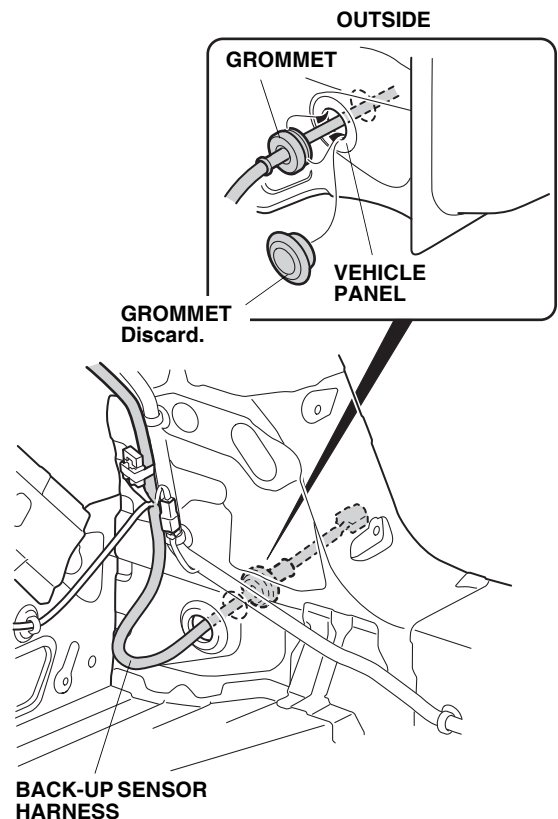

40. Using three wire ties, secure the back-up sensor harness to the vehicle harness.

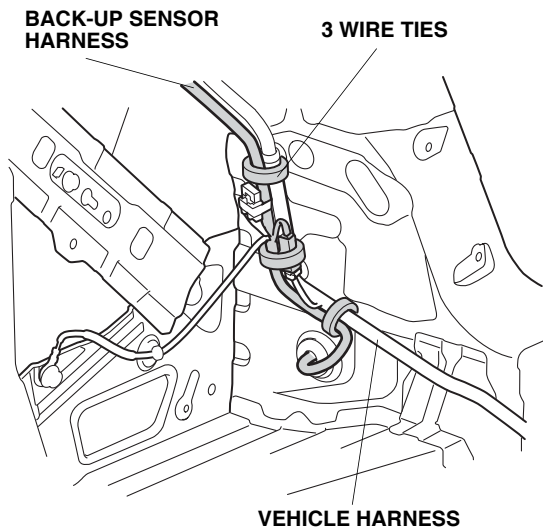

41. Outside the vehicle, secure the back-up sensor harness to the hole in the bumper beam at the green tape using one wire tie. If the vehicle is equipped with a trailer hitch, secure the harness to the trailer hitch bracket.

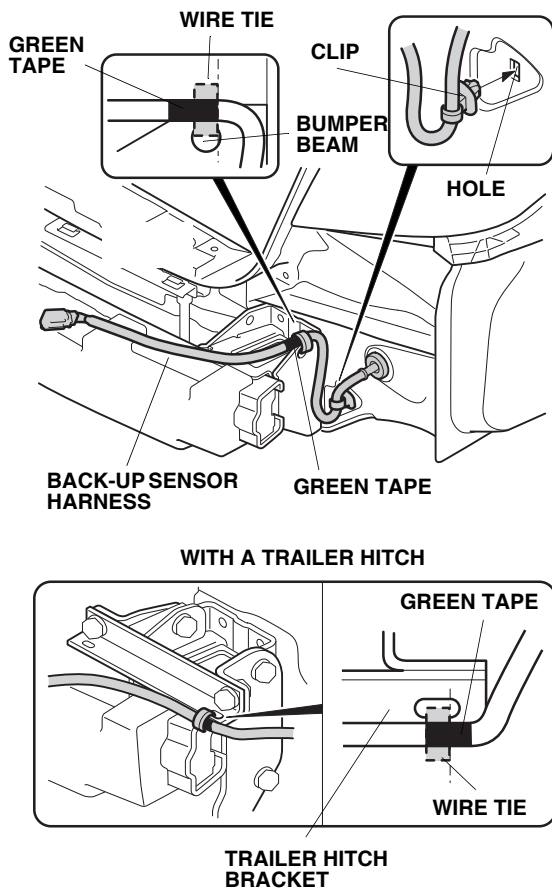

42. Insert the clip on the back-up sensor harness into the hole in the vehicle panel.

Installing the Switch

43. Locate and mark the right rear side liner at the location shown. Using a pushpin, pierce the right rear side liner at the measurement shown.

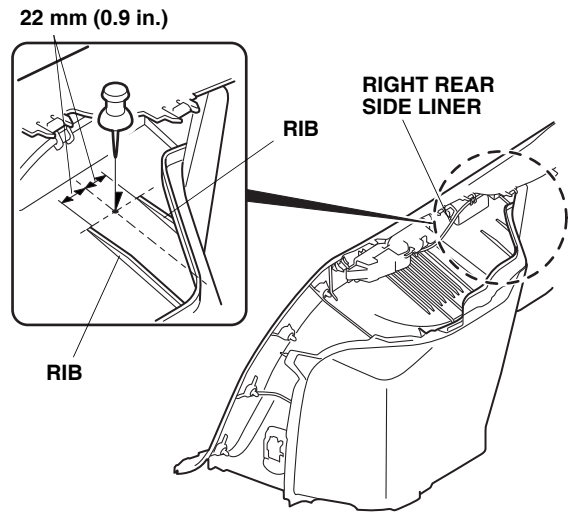

44. While wearing eye protection, drill the right rear side liner at the pierced mark. First drill with a 3 mm drill bit, and finish with a 26 mm hole saw. Remove any burrs.

NOTE: If the switch does not fit properly, check that all the burrs have been removed.

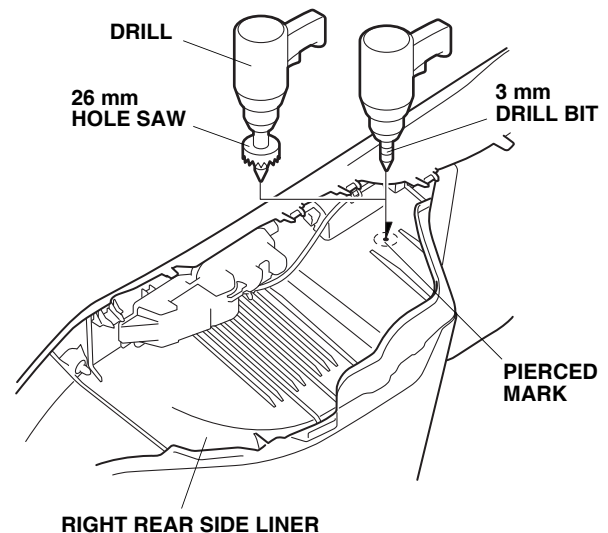

45. Insert the switch into the drilled hole, and install the switch bracket to the switch in the direction shown.

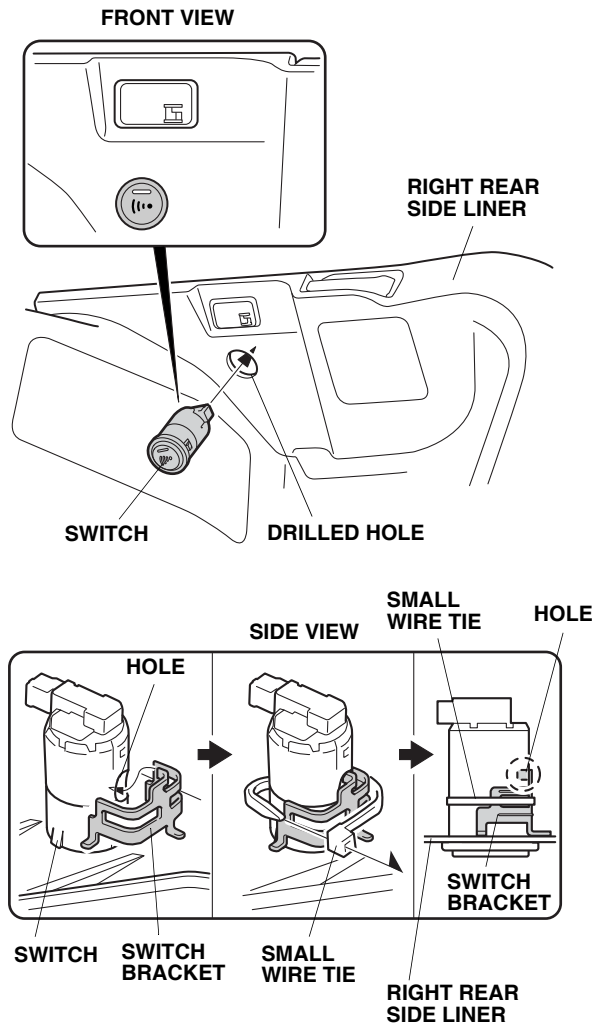

46. Using one small wire tie, secure the switch bracket to the switch.
- NOTE:** Be sure the switch bracket is tight against the right rear side liner, otherwise, the switch may not install properly between the switch and the right rear side liner.

47. Plug the back-up sensor harness 3-pin connector into the switch.

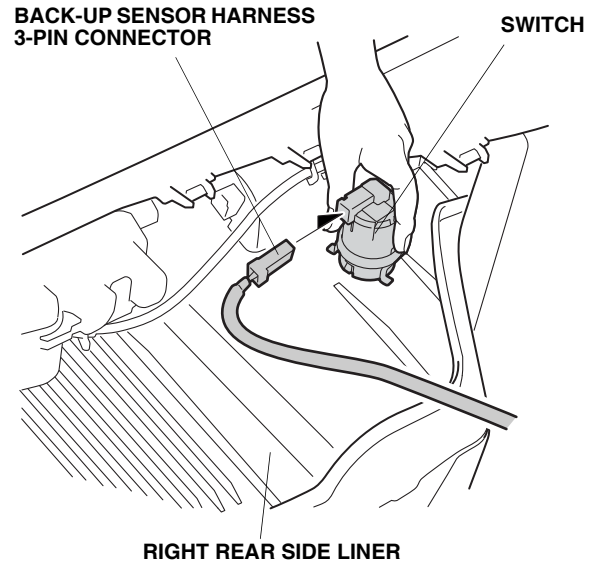

48. Reinstall the right rear side liner. Be careful not to bump the switch during installation.

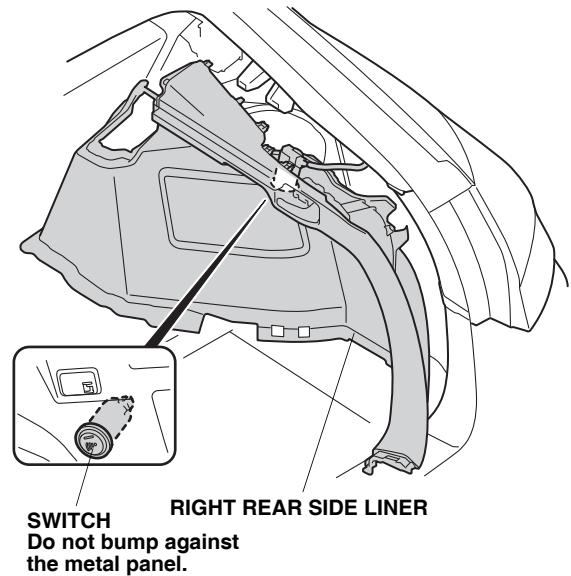

Installing the Sensors

49. On the inside of the rear bumper, locate the rear sensor preset marks. Using a pushpin, pierce the center and top of each preset mark (four places).
NOTE: There are several marks on the inside of the rear bumper, be sure that you locate the proper preset marks.

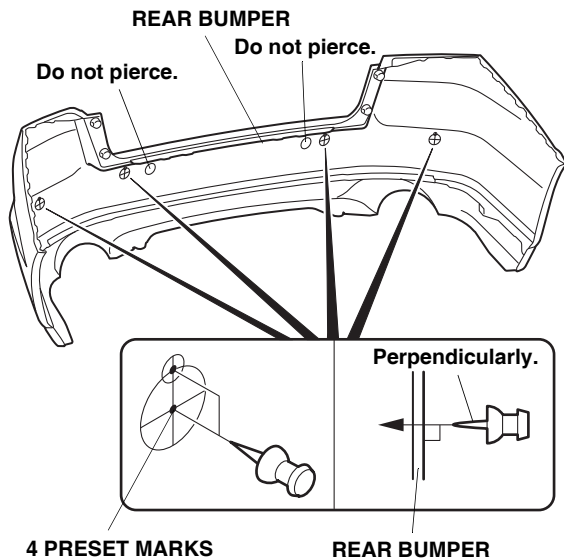

50. While wearing eye protection, drill a 3 mm hole at each of eight pierced points you made in the rear bumper.
NOTE: Drill from the painted side of the bumper.

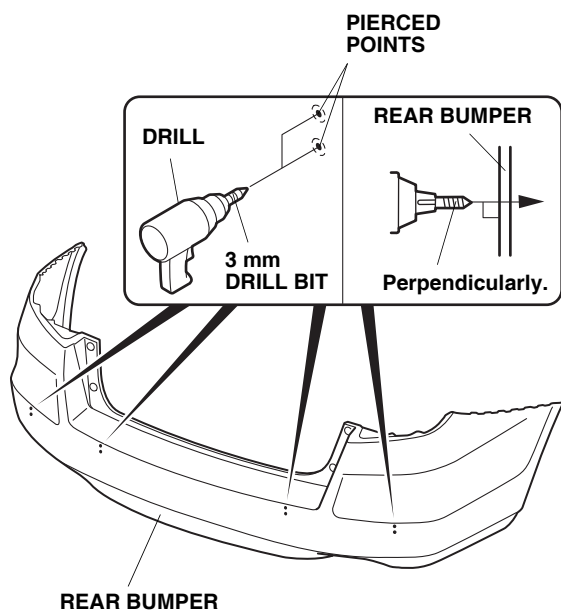

51. While wearing eye protection, enlarge the lower corner holes to 24 mm using a 24 mm hole saw.
NOTE: The corner sensor holes are 24 mm.

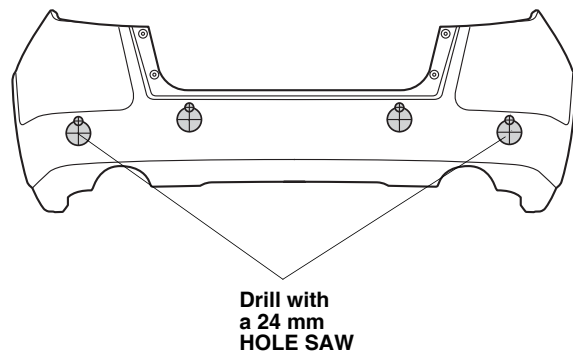
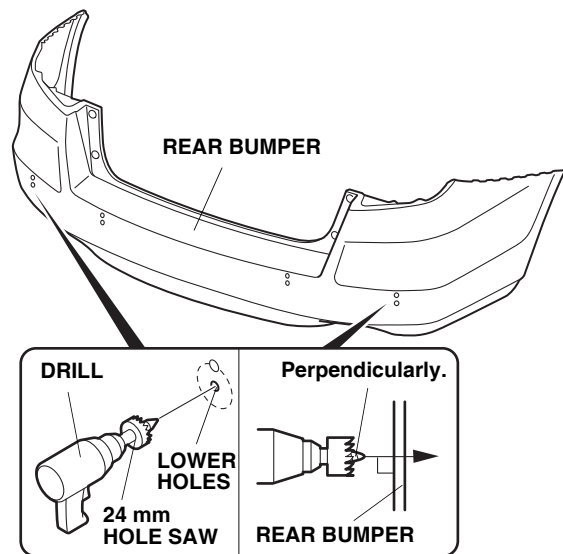

52. While wearing eye protection, enlarge the lower center holes to 26 mm using a 26 mm hole saw.
NOTE: The center sensor holes are 26mm.

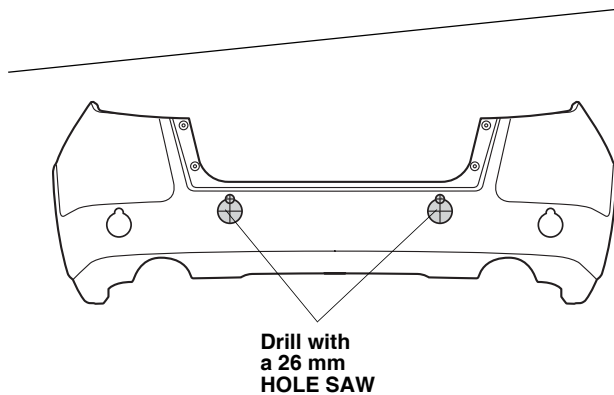
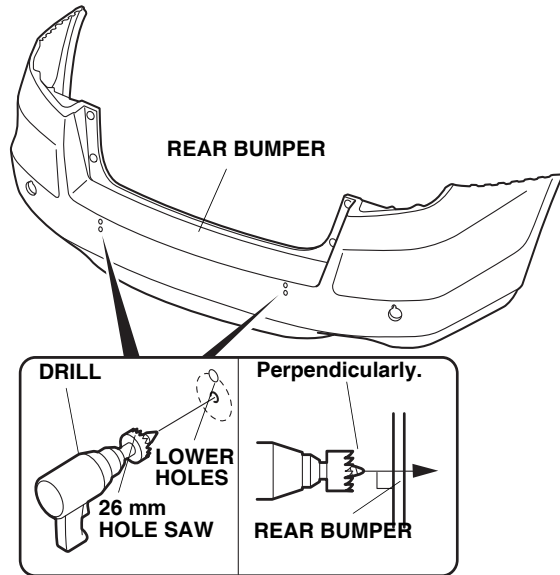

53. Install the sensors into the rear bumper. Use the colors to identify the location of each sensor.
NOTE:

- The sensor detent must be positioned at the 12 o'clock position for the sensor to operate correctly.
- The left center sensor and right corner sensors have yellow dots.

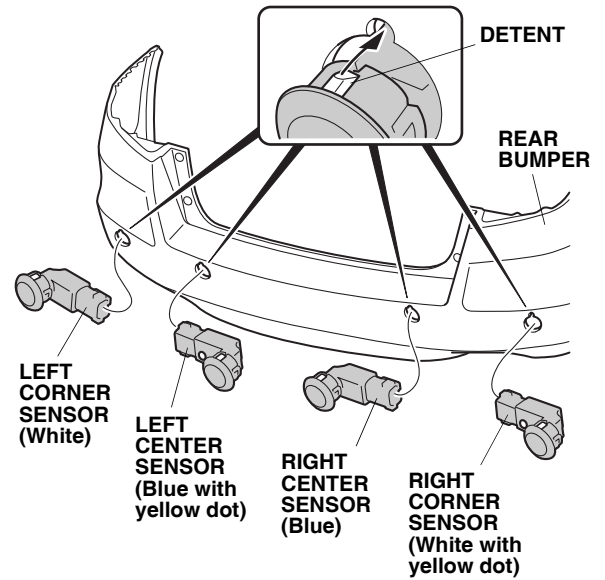

54. Install the sensor clips as shown.

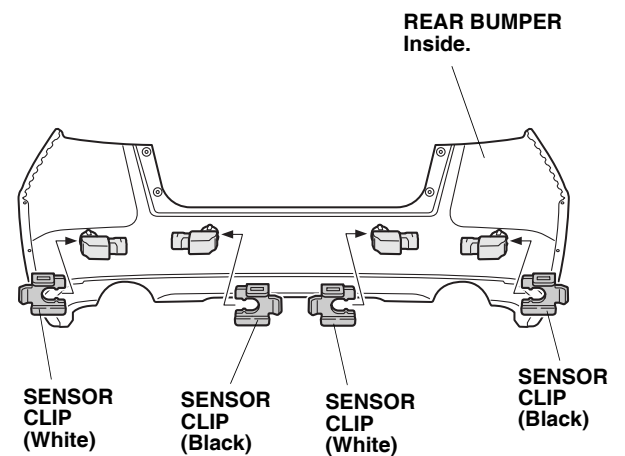

55. Plug in the back-up sensor subharness 2-pin connectors to each sensor.

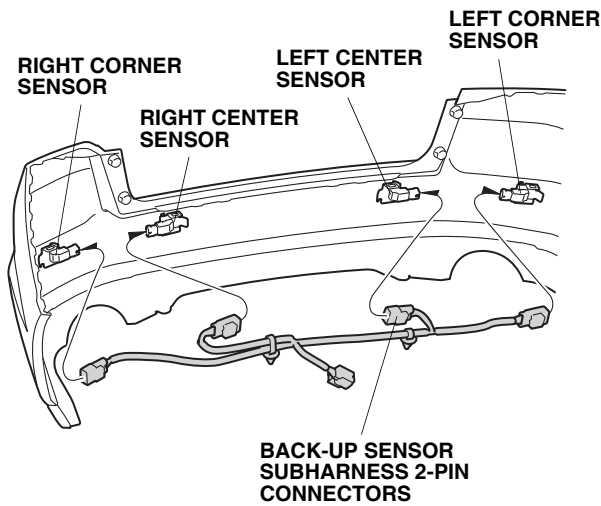

56. Install the two back-up sensor subharness clips into the holes in the center sensor clips.

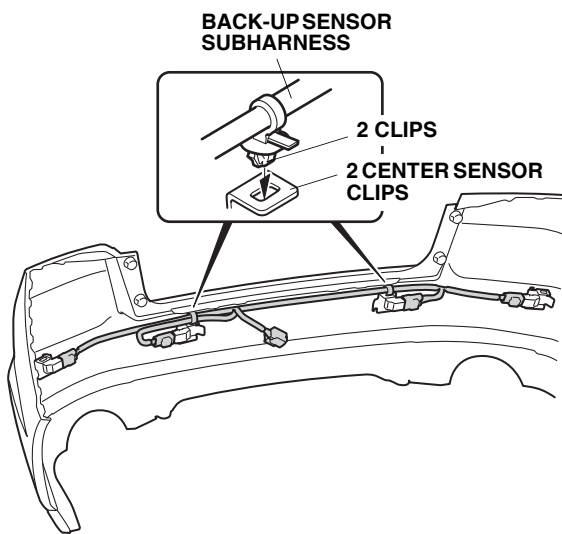

57. Using isopropyl alcohol on a shop towel, clean the areas where the aluminum tapes will attach. Using four aluminum tapes, secure the back-up sensor subharness to the rear bumper.

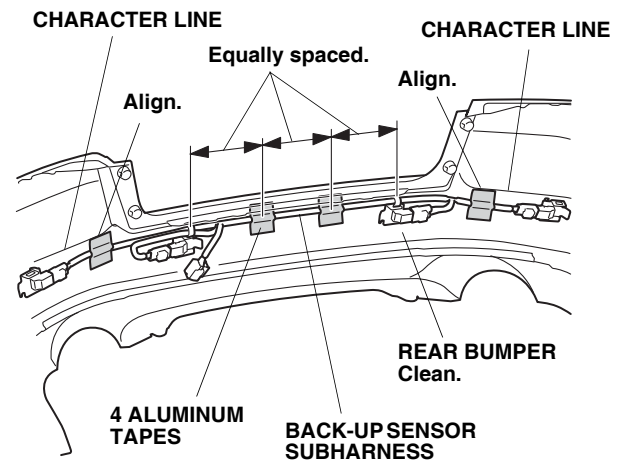

58. Using the wire tie with clip B, secure the back-up sensor subharness connector to the back-up sensor subharness.

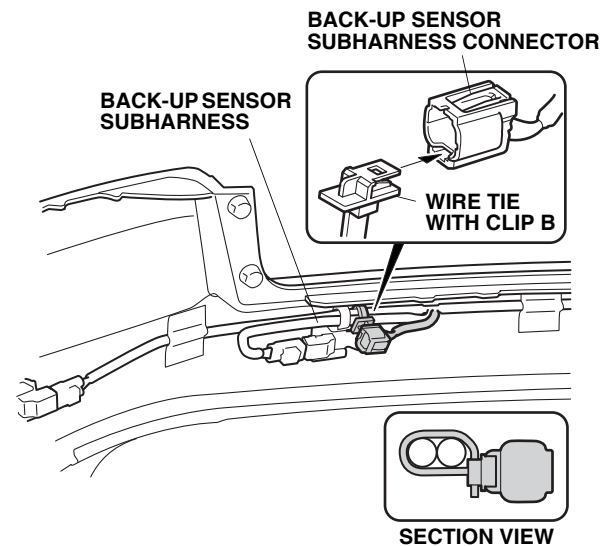

59. Plug the back-up sensor harness 8-pin connector into the back-up sensor subharness 8-pin connector, then reinstall the rear bumper. Have an assistant help you when installing the rear bumper.

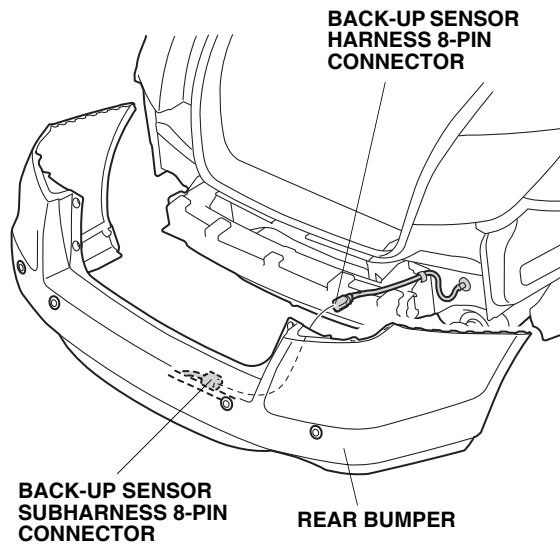

60. Check that all wire harnesses are routed properly and that all connectors are plugged in.
61. Reinstall all removed parts.
62. Reconnect the negative cable to the battery.
63. Enter the anti-theft codes for the radio and navigation systems, then enter the customer's radio presets.
64. Reset the clock.
65. Check that the back-up sensors work properly as described in the Accessory User's Information Manual supplied with the backup sensor attachment kit.

BUZZER VOLUME CONTROL

The volume control knob on the control unit is turned to maximum volume. After confirming the system operation, turn the volume control knob to the appropriate volume.

