



**INSTALLATION
INSTRUCTIONS**

Accessory

**FOG LIGHTS (L4)
P/N 08V31-TA0-100A**

Application

**2011 ACCORD
4-DOOR**

Publications No.

All 44025

Issue Date

AUG 2010

PARTS LIST

Left fog light

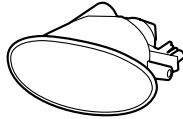

Right fog light



2 Fog light harnesses

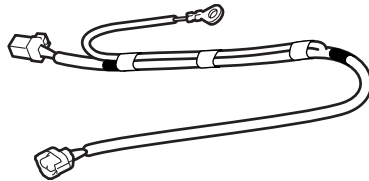

Left bracket



Right bracket

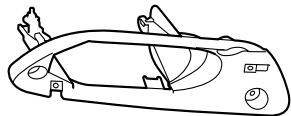

Left fog light trim



Right fog light trim

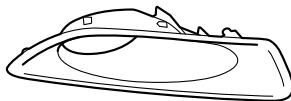

4 Wire ties

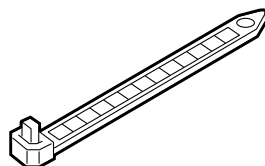

2 Wire ties with clip

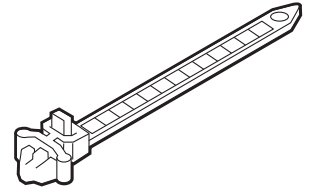

4 Screws, 4 mm



2 Washer-screws, 4 x 8 mm



6 Black self-tapping screws, 5 x 16 mm



4 Silver self-tapping screws, 5 x 16 mm



4 Spring nuts



Ground bolt



Lighting switch

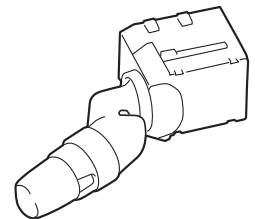

TOOLS AND SUPPLIES REQUIRED

Phillips screwdriver
Flat-tip screwdriver
Diagonal cutters
Ratchet
10 mm Socket
10 mm Open end wrench
Drill
3 mm and 7 mm Drill bits
24 mm and 26 mm Hole saws
Pushpin
Air saw (Snap-On AT192A)
Gloves
Tape
File
Trim Tool Set (T/N SOJATP2014)
Eye protection (face shield, safety goggles, etc.)
Blanket

Illustration of the Fog Lights Installed on the Vehicle

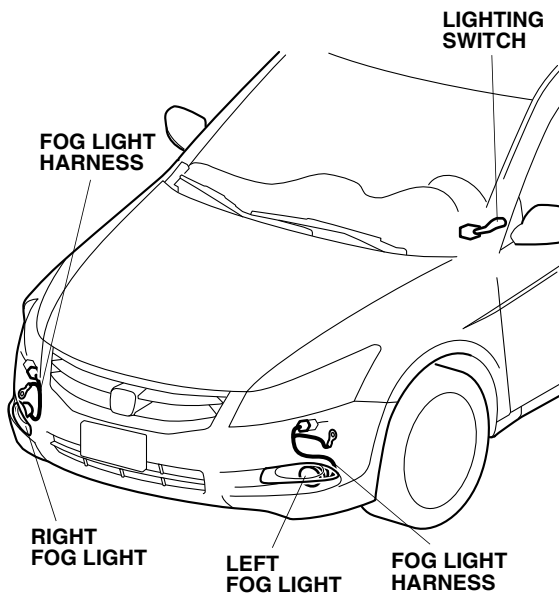

INSTALLATION

Customer Information: The information in this installation instruction is intended for use only by skilled technicians who have the proper tools, equipment, and training to correctly and safely add equipment to your vehicle. These procedures should not be attempted by “do-it-yourselfers.”

1. Make sure you have the anti-theft code for the audio and navigation system (if equipped).
2. Disconnect the negative cable from the battery.

Removing Parts (Vehicle Exterior)

3. Remove the front bulkhead cover (two long clips and five short clips).

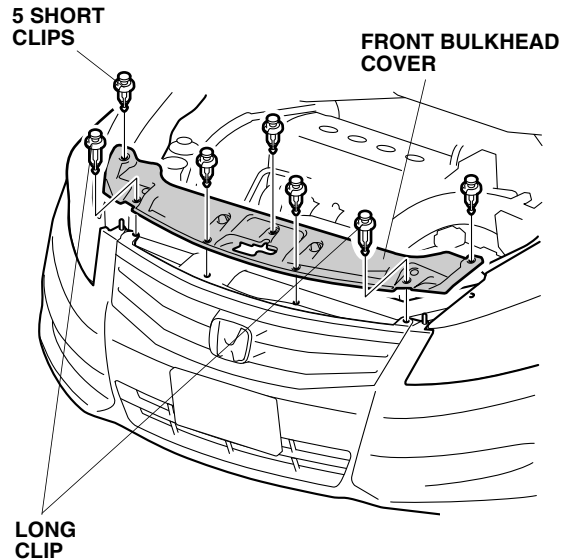

- Attach tape to the front bumper as shown.

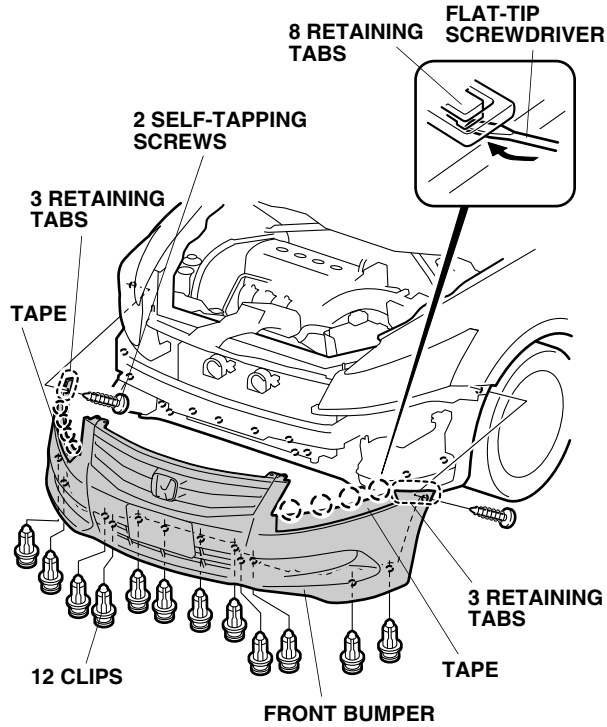

- Remove two self-tapping screws and twelve clips.
- Remove the front bumper (fourteen retaining tabs). **NOTE:** Have an assistant help you when removing to the front bumper. Place the front bumper on a blanket after removal.

Installing the Fog Light

- Inside the front bumper on the driver's side, locate twelve scribe marks. Using a pushpin, pierce through the front bumper at each scribe mark. **NOTE:** There are several marks on the inside of the front bumper, make sure to you locate the proper marks.

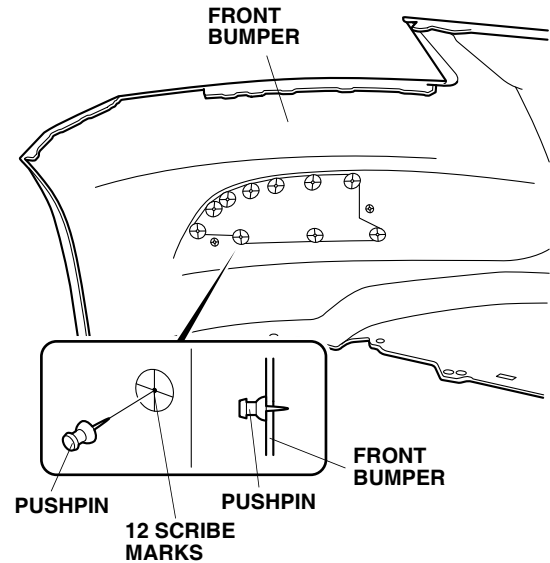

- While wearing eye protection, drill 7 mm holes through the front bumper at two marks shown. First drill with a 3 mm drill bit, then finish with a 7 mm drill bit.

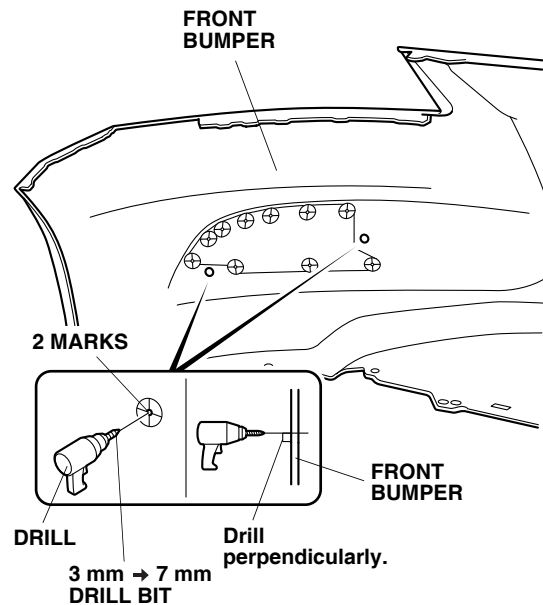

9. Drill the remaining ten marks to 24 mm. First drill with a 3 mm drill bit, then enlarge the holes with a 24 mm hole saw.

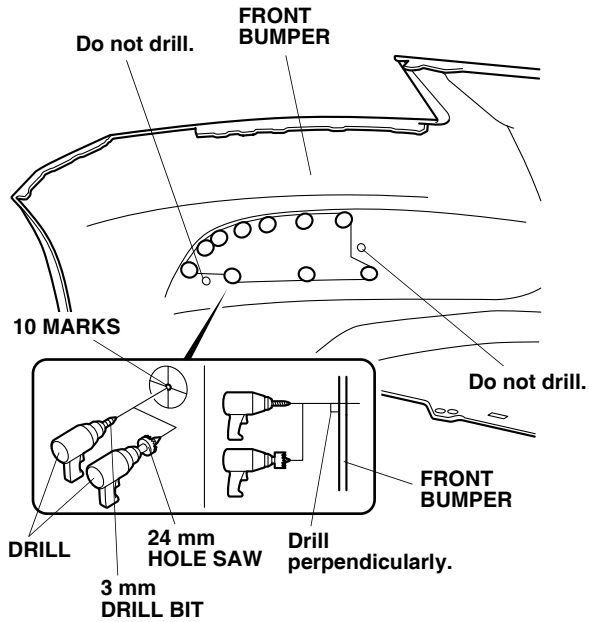

10. Cut the front bumper along the scribe line as shown. NOTE: Remove any burrs.

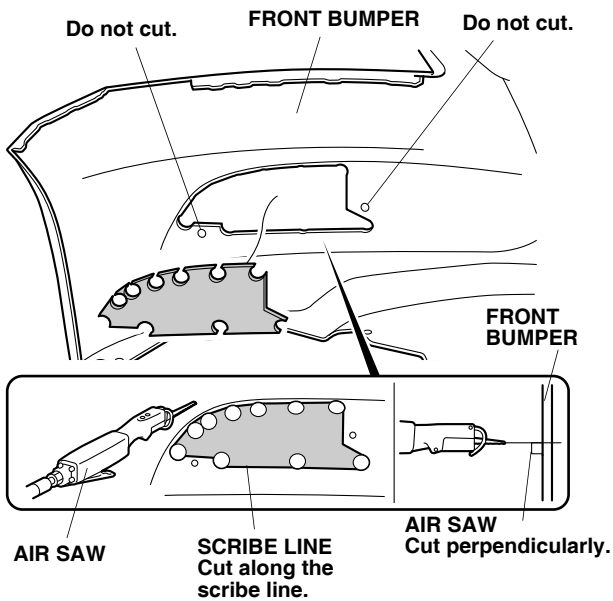

11. Install the left fog light to the left bracket with two 4 mm screws and one 4 x 8 mm washer-screw.

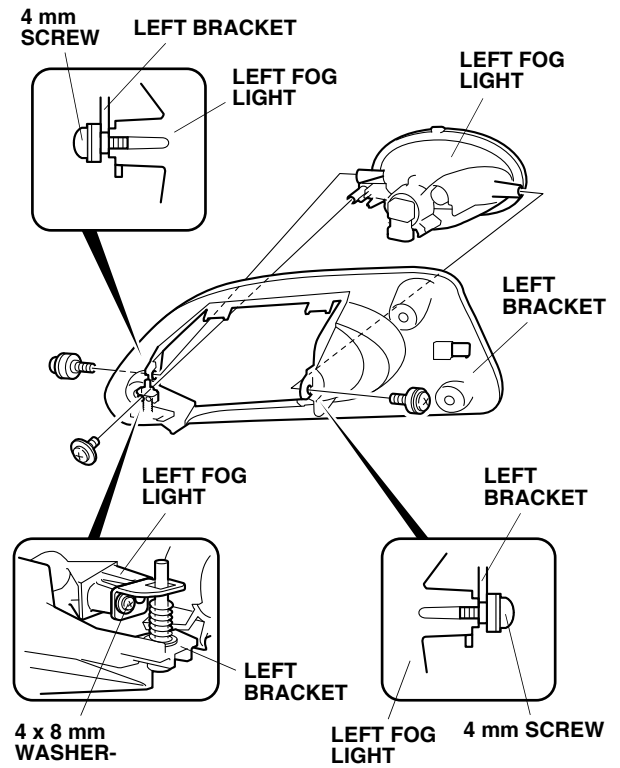

12. Install two spring nuts on the left bracket.

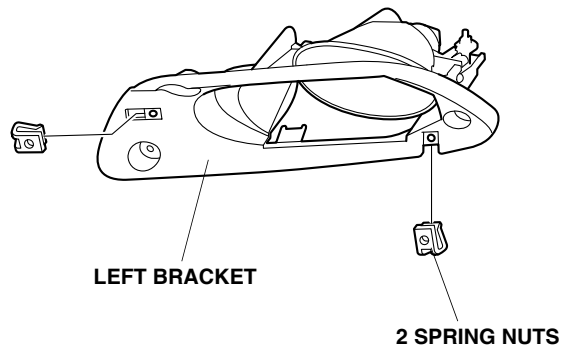

13. Install the left bracket to the front bumper with two 5 x 16 mm silver self-tapping screws.

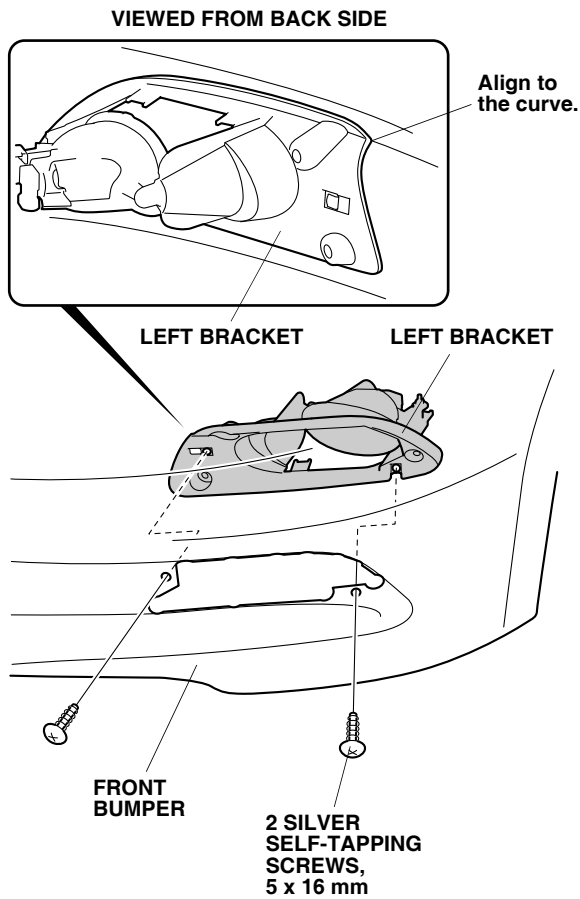

14. Install the left fog light trim to the front bumper with three retaining tabs.

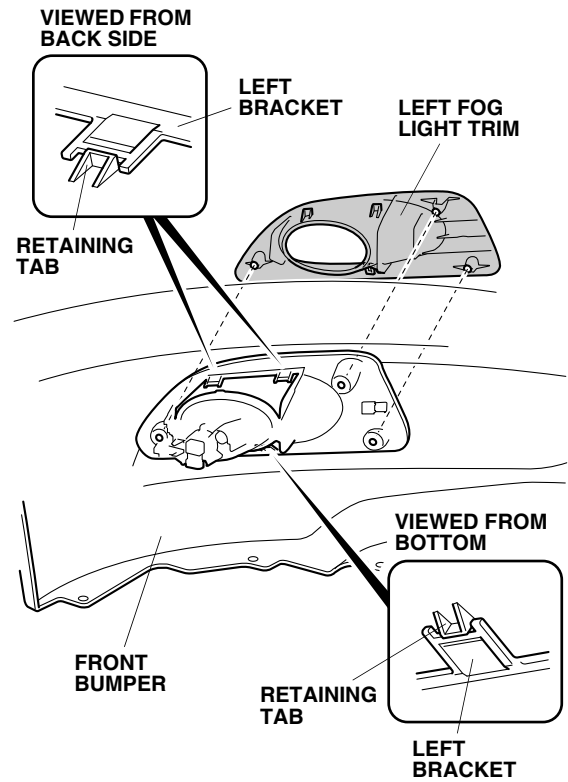

15. Secure the left fog light trim to the front bumper with three 5 x 16 mm black self-tapping screws.

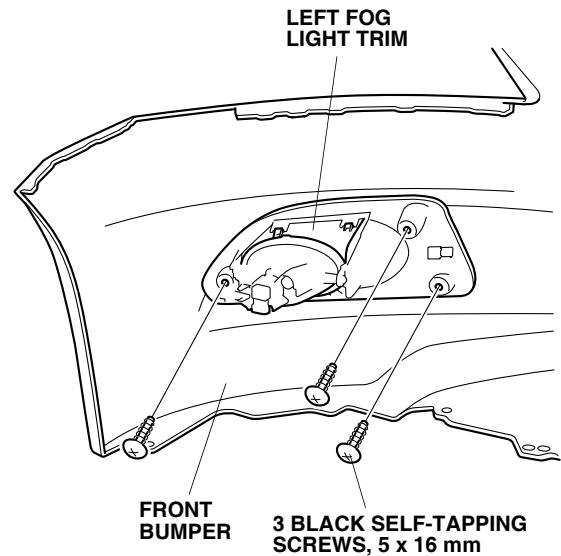

16. Repeat steps 7 through 15 to install the right fog light and trim.

Routing the Fog Light Harness

17. On the passenger's side of the vehicle, locate the 1-pin connector blue taped to the vehicle harness. Remove the tape to release the connector.

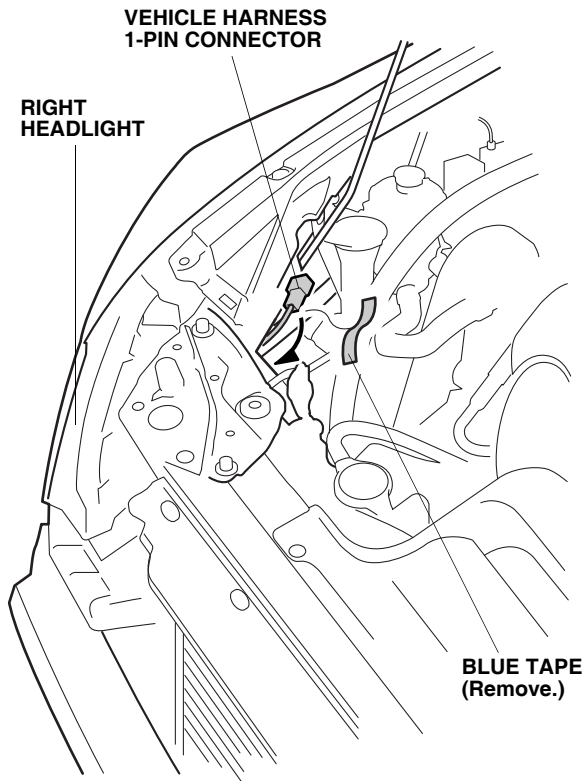

18. Plug the fog light harness 1-pin connector into the vehicle harness 1-pin connector.

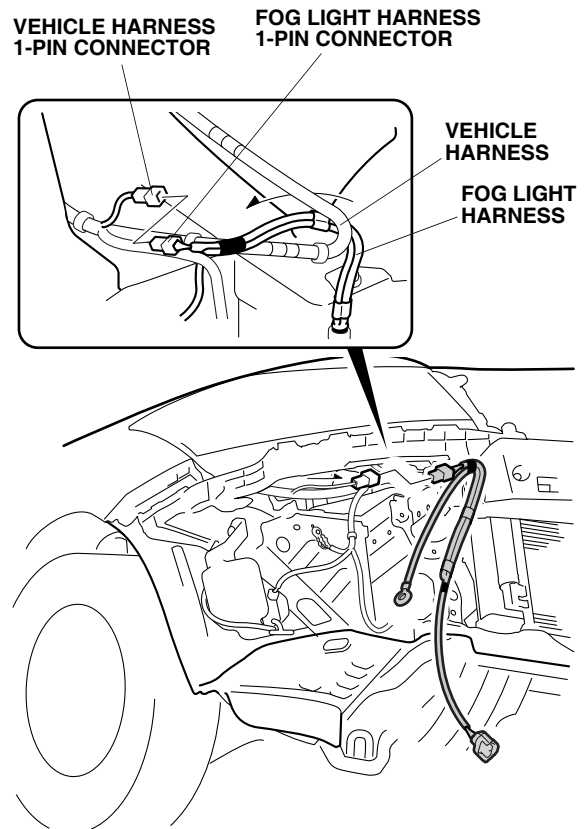

19. Secure one wire tie with clip to the fog light harness at the green tape. Secure the wire tie with clip to the hole in the vehicle frame.

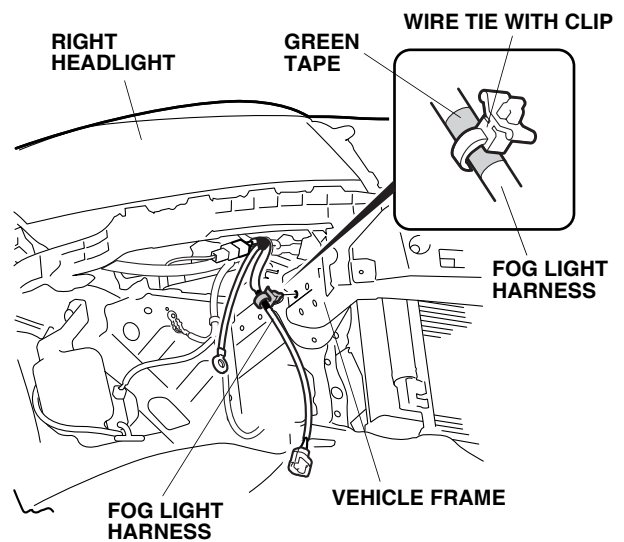

20. Near the 1-pin connector, secure the fog light harness to the vehicle harness with two wire ties at the green tape.

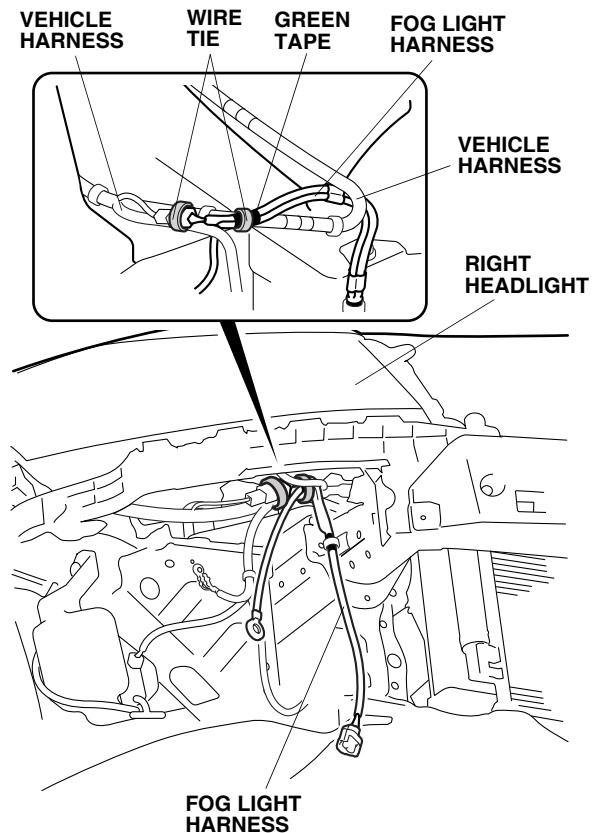

If the vehicle is equipped with the vehicle ground terminal, go to step 21; if not, go to step 22.

With vehicle ground terminal

21. Locate and remove the vehicle ground bolt. Secure the fog light harness ground terminal and vehicle ground terminal to the vehicle frame with the vehicle ground bolt just removed. Go to step 23.

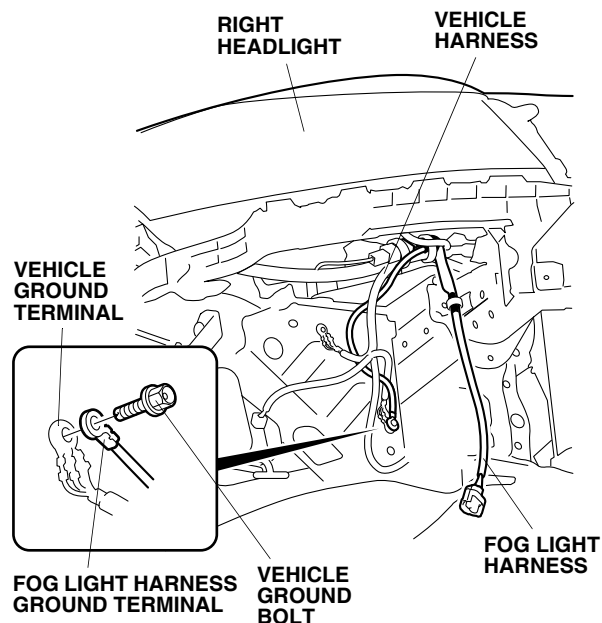

Without vehicle ground terminal

22. Secure the fog light harness ground terminal to the vehicle frame with the supplied ground bolt.

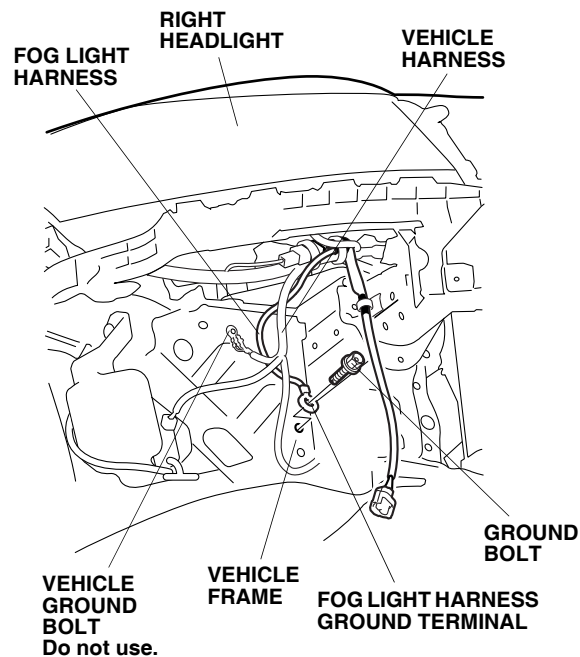

23. On the driver's side of the vehicle, locate the vehicle harness 1-pin connector. Plug the fog light harness 1-pin connector to the vehicle harness 1-pin connector.

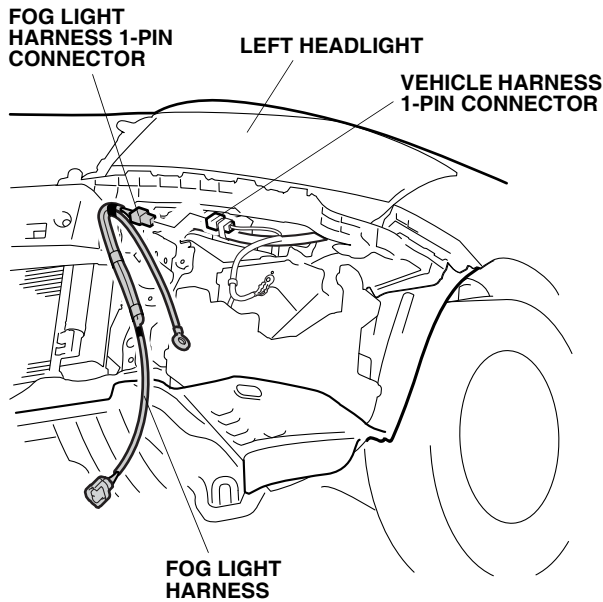

24. Secure one wire tie with clip to the fog light harness at the green tape. Secure the wire tie with clip to the hole in the vehicle frame.

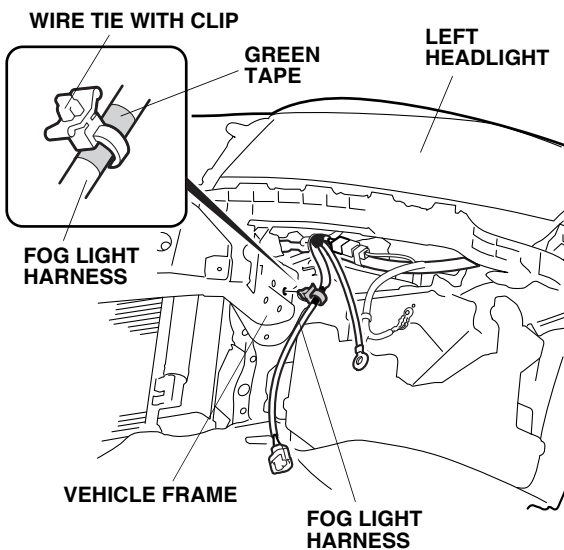

25. Near the 1-pin connector, secure the fog light harness to the vehicle harness with one wire tie at the green tape.

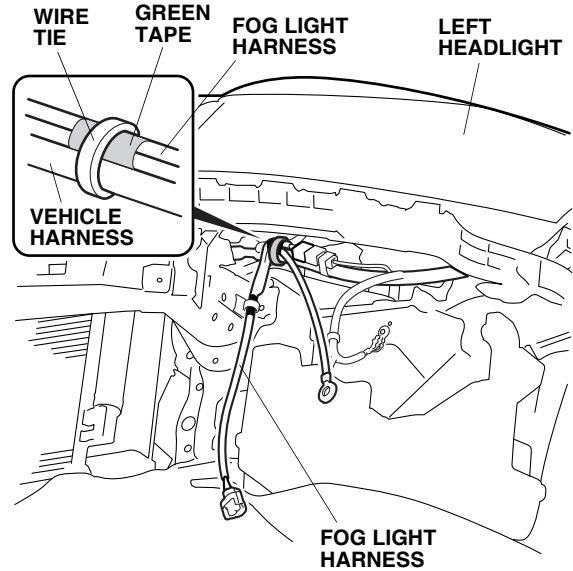

26. Locate and remove the vehicle ground bolt. Secure the fog light harness ground terminal and vehicle ground terminal to the vehicle frame with the vehicle ground bolt just removed.

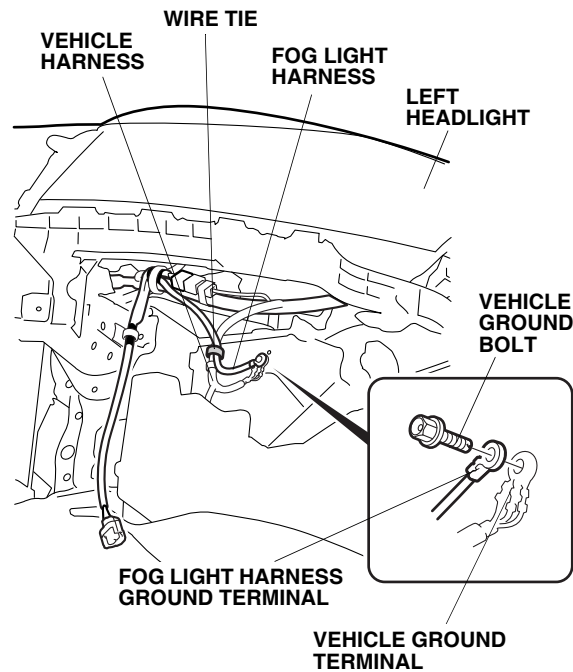

27. Near the ground terminal, secure the fog light harness to the vehicle harness with one wire tie.

28. Turn the steering wheel fully clockwise.

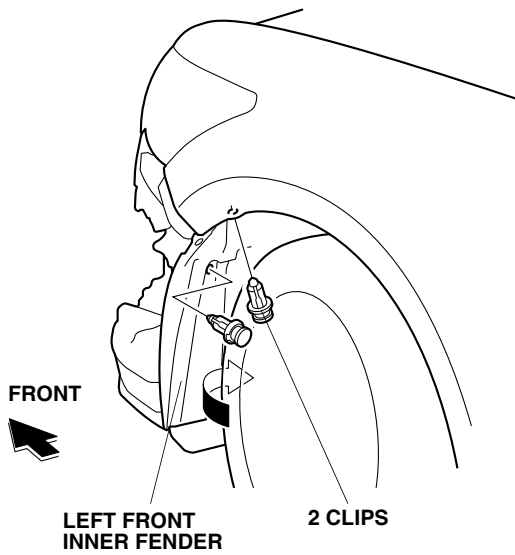

29. Remove two clips from the left front inner fender.
30. Pull down the left front inner fender.

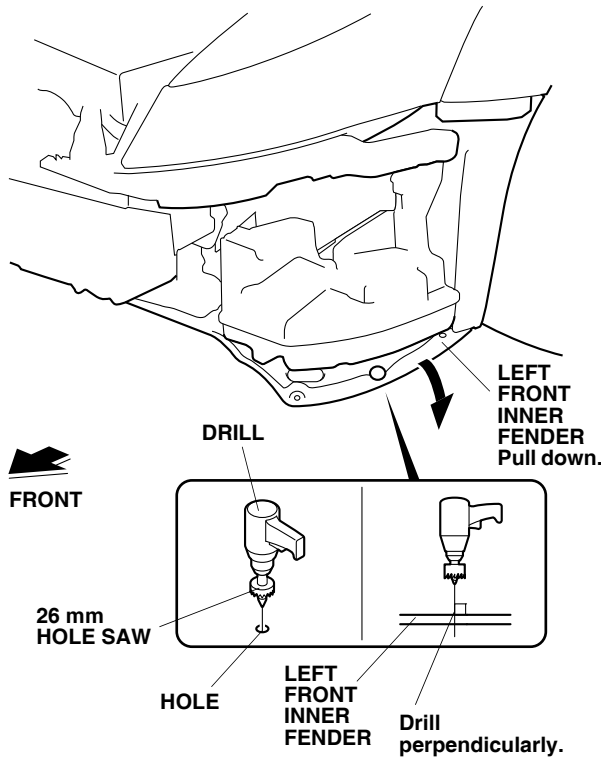

31. While wearing eye protection, enlarge the hole in the left front inner fender with a 26 mm hole saw.
NOTE: Make sure to drill perpendicularly to the inner fender. Remove any burrs.

32. Enlarge the hole in the right front inner fender with a 26 mm hole saw.
NOTE: Make sure to drill perpendicularly to the inner fender. Remove any burrs.

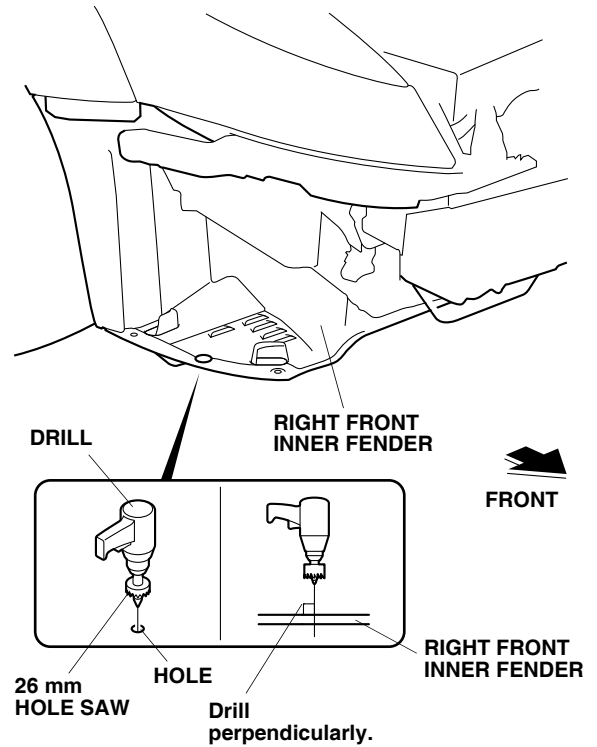

33. Plug the fog light harness connectors into the fog lights.

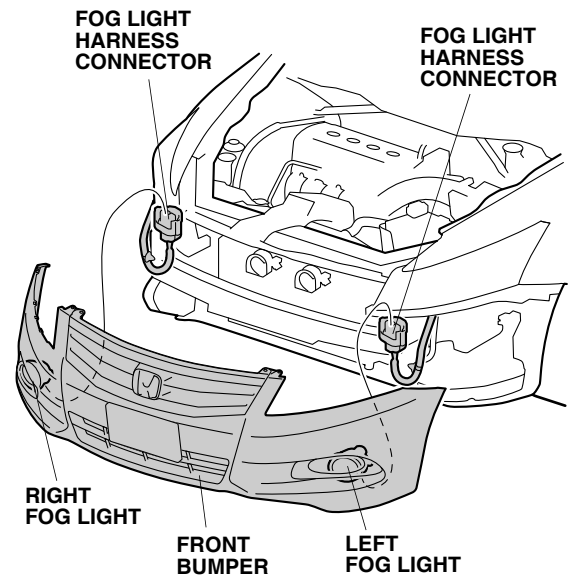

34. Reinstall the front bumper.
NOTE: Have an assistant help you when installing the front bumper.

Installing the Lighting Switch

35. Lower the tilt lever and pull the steering wheel out.

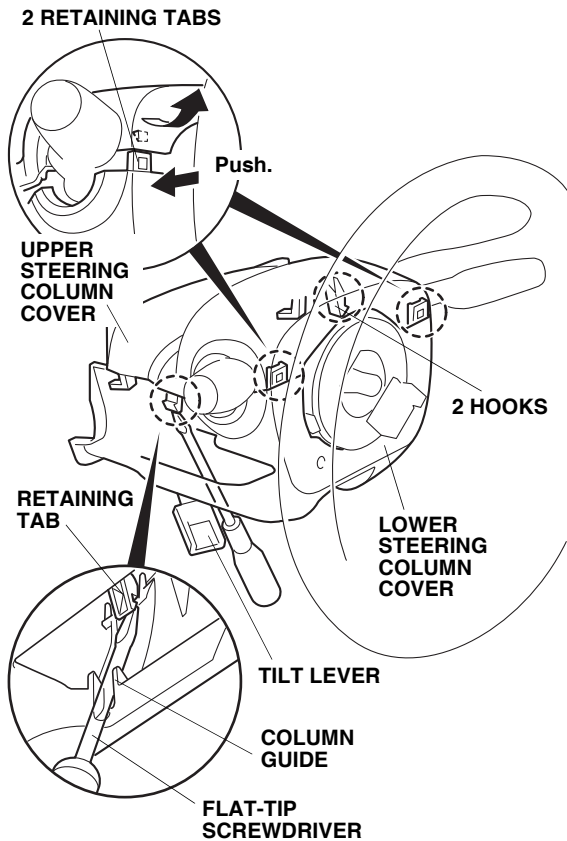

36. Remove the upper steering column cover:
- Insert a flat-tip screwdriver along the column guide inside the lower cover, and gently pry out on the retaining tab on the upper column cover.
 - Push the lower cover to release two retaining tabs, and pull up on the upper cover to release two hooks.

37. Remove the lower steering column cover (three screws). The upper screws are self-tapping screws.

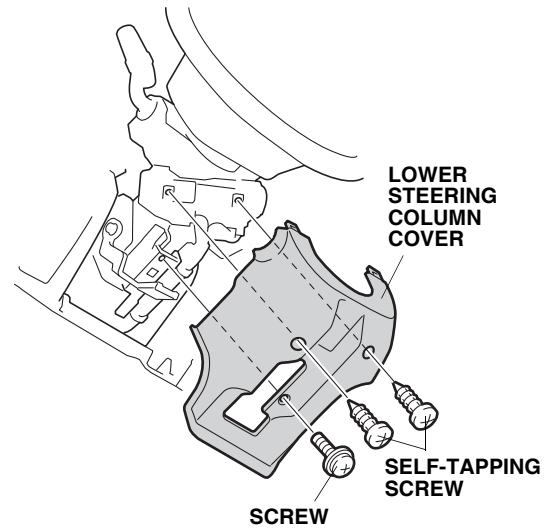

38. Turn the steering wheel 90° counterclockwise, and unplug the vehicle connector from the lighting switch.

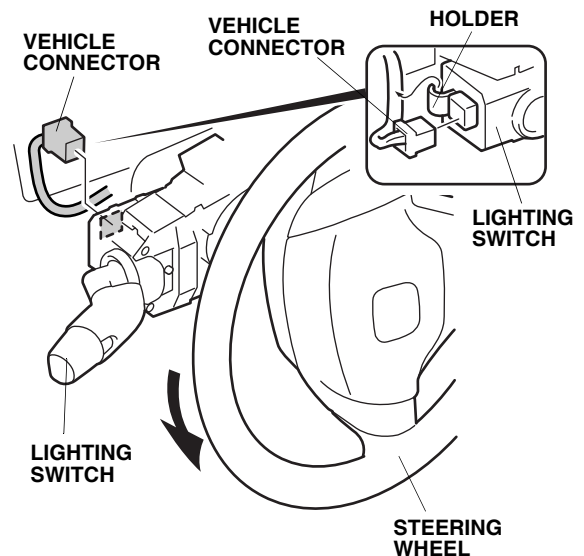

39. Remove two self-tapping screws from the lighting switch. While pushing the retaining tab, slide the lighting switch out of the bracket, and remove it from the steering column.
- Do not pull on the lever when removing the case. Do not damage the tab hole in the steering column.

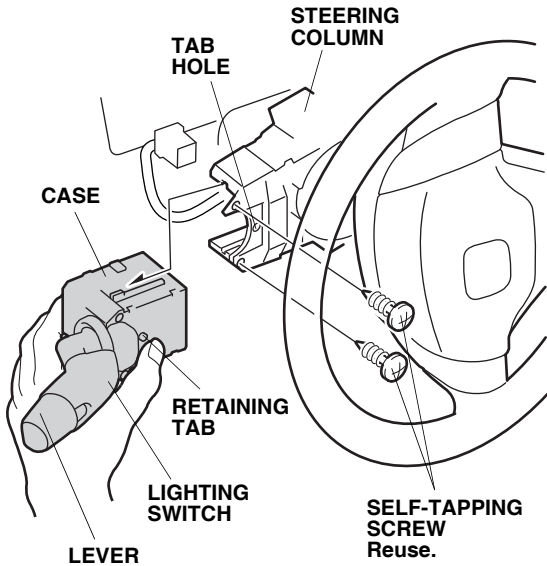

40. Holding the case in your hand, install the new lighting switch to the steering column. Install the two self-tapping screws.
- Do not push on the lever when installing the case. Push on the case and set the retaining tab in to the tab hole.

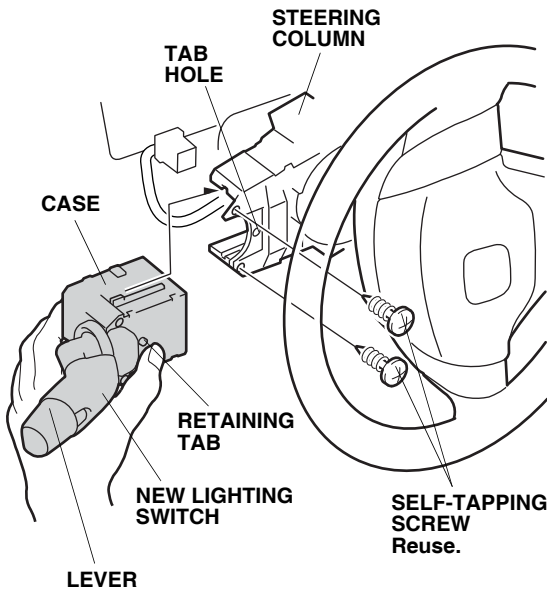

41. Plug the vehicle connector to the new lighting switch.

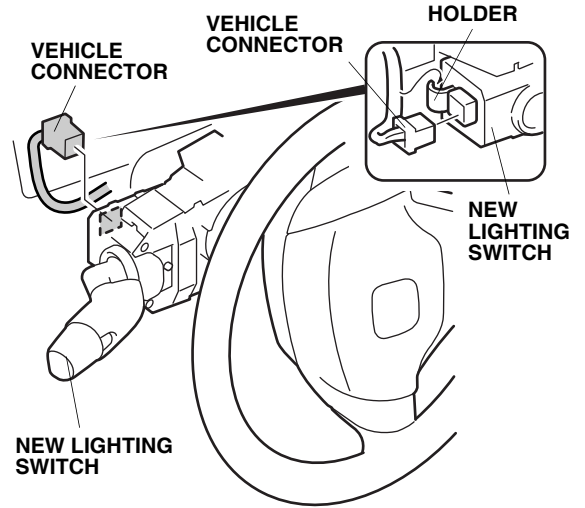

42. Check that all wire harnesses are routed properly and all connectors are plugged in.
43. Reinstall all removed parts.
44. Enter the anti-theft codes for the customer's audio and navigation system, if equipped, and reset the radio station presets.
45. Reconnect the negative cable to the battery.
46. Reset the clock.

USE AND CARE

How to Operate the Fog Lights

- Turn the headlight switch to the “D” position (headlights on low beam).
- Turn the fog light switch on (indicator is on).

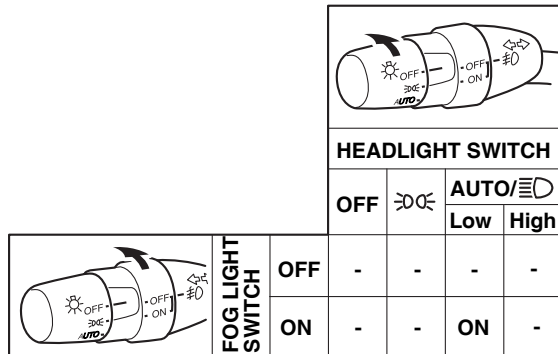

NOTE: The fog light lenses can cloud when the outside temperature is cold; this is normal and should go away in warm weather.

- If the fog lights do not turn on, check the fuse and all the connectors, including the ground cable.

Fog Light Aiming Adjustment

47. Adjust the fog lights:

- Adjust the aim according to local laws and regulations.
- To adjust, turn the aiming adjustment knob in or out until the correct aim is obtained.

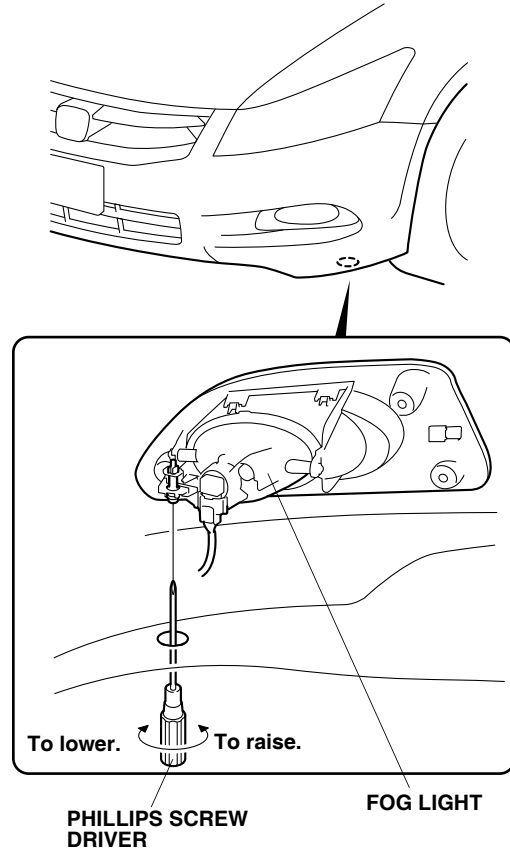

BULB REPLACEMENT

1. Turn the steering wheel counterclockwise. Remove two clips, and pull back the inner fender.



2. Insert your hand inside of the inner fender pulled back in step 1. Unplug the connector from the fog light, and remove the bulb by turning it counterclockwise.

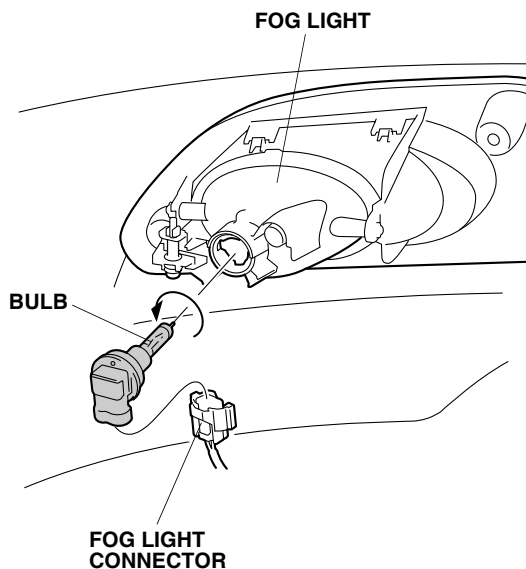

3. Install the new bulb and socket to the fog light.
 - Use only a Genuine Honda halogen light bulb of specified wattage.
Rating: 12V 55W H11 Halogen Light Bulb P/N33165-S5A-003
 - Do not touch the bulb. Oily or greasy substances on the bulb can shorten its service life due to the heat produced when the bulb is turned on. If the bulb is accidentally touched, wipe it clean with a soft cloth that has been dampened with a denatured alcohol or a mild detergent solution.
 - When installing the new bulb, align the cutout on the fog light with the tab on the new bulb and turn the new bulb in completely. If not properly aligned, the fog light may affect the oncoming driver's view.

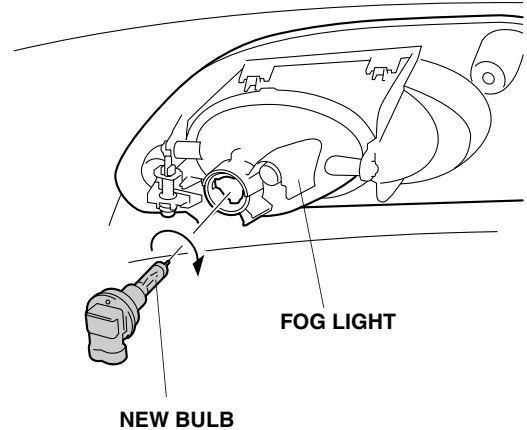
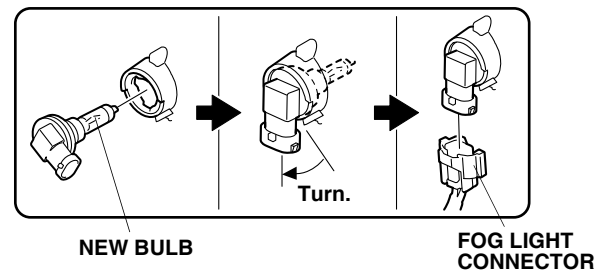

4. Reinstall the removed parts. Check that the wire harnesses are not pinched. Be sure to install the clips securely.
5. Check the operation of the fog light; adjust the aim if necessary.