



**INSTALLATION  
INSTRUCTIONS**

Accessory

**AMBIENT LIGHT  
P/N 08E10-TA0-100A**

Application

**2011 ACCORD  
2 AND 4-DOOR**

Publications No.

**All 43992**

Issue Date

**AUG 2010**

**PARTS LIST**

**Ambient Light Kit**

2 Ambient lights

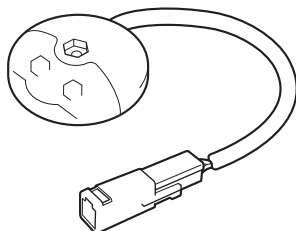

Ambient light harness

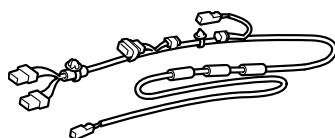

2 Brackets

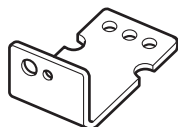

Ambient light switch

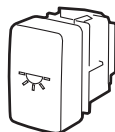

Switch trim

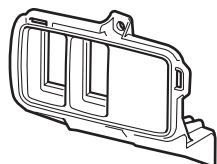

Template

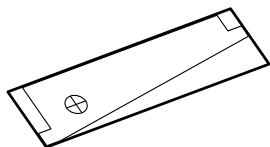

Fuse label

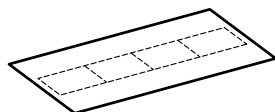

Washer screw, 6 x 16 mm

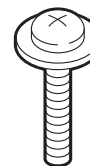

Self-tapping screw, 4 x 16 mm



2 Pan screws, 4 x 20 mm



7 Wire ties

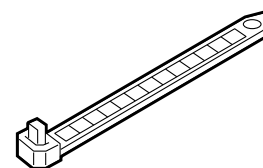

Wire tie with clip

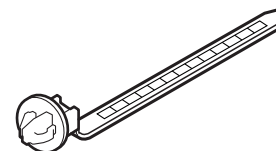

2 Flange nuts, 4 mm



Flange nut, 6 mm



## TOOLS AND SUPPLIES REQUIRED

Phillips screwdriver  
Flat-tip screwdriver  
Insulation tape  
Steel wire  
Scissors  
Pushpin  
Diagonal cutters  
Ratchet  
8 mm and 10 mm Socket  
10 mm Open end wrench  
Drill  
3 mm, 5 mm, 7 mm, and 10 mm Drill bits  
Trim Tool Set (T/N SOJATP2014)  
Eye protection (face shield, safety goggles, etc.)  
File  
Isopropyl alcohol  
Shop towel  
Utility knife

### *Illustration of the Ambient Light Installed in the vehicle*

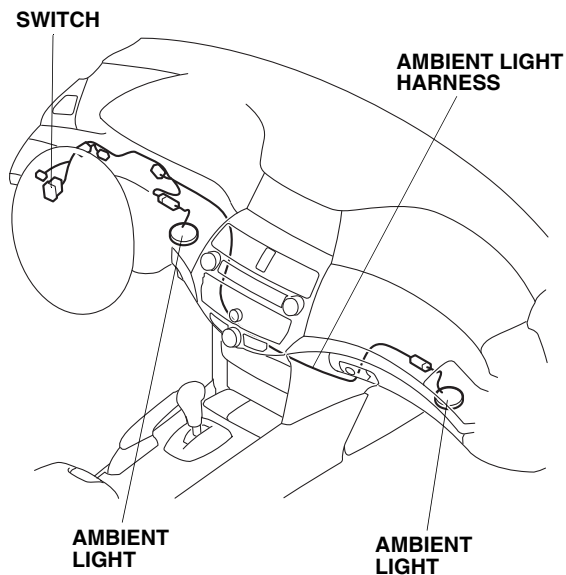

## INSTALLATION

**Customer Information:** The information in this installation instruction is intended for use only by skilled technicians who have the proper tools, equipment, and training to correctly and safely add equipment to your vehicle. These procedures should not be attempted by “do-it-yourselfers.”

1. Make sure you have the anti-theft codes for the audio and navigation system (if equipped).
2. Disconnect the negative cable from the battery.

### Removing Parts

3. Remove the driver's dashboard lower cover (eight clips, two hooks, and unplug the vehicle connector).

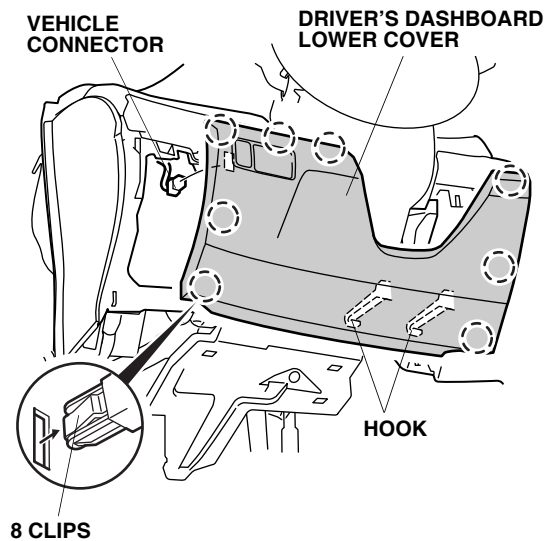

4. *V6 model only:* Remove the driver's dashboard under cover (three clips and one pin).

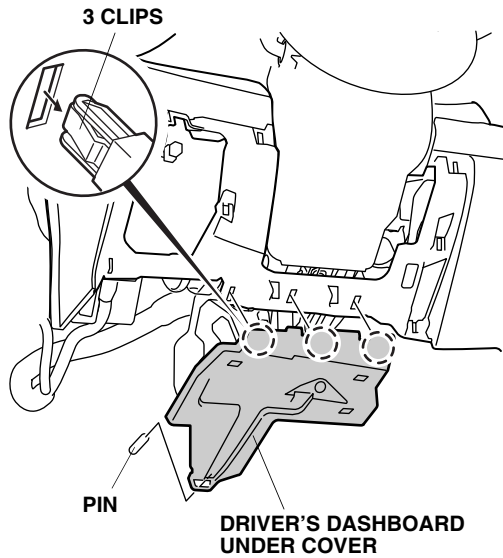

If the vehicle is equipped with HandsFreeLink (HFL), go to step 5; if not, go to step 8.

With HFL

5. Pull away the door seal from around the dashboard left side cover.

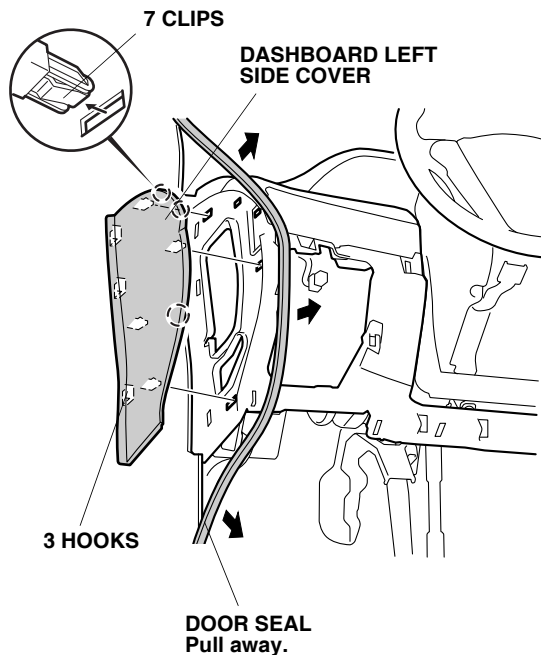

6. Remove the dashboard left side cover (seven clips and three hooks).

7. Remove the HFL control unit (two bolts and unplug the vehicle 28-pin connector).

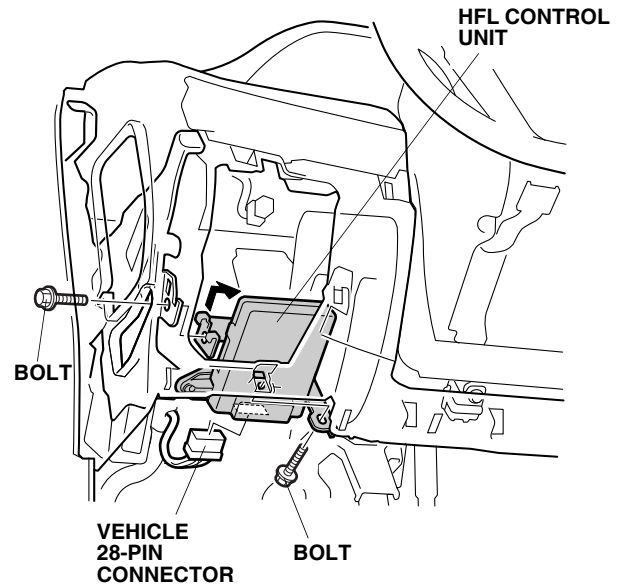

8. *V6 model only:* Remove the passenger's dashboard under cover (three clips and two pins).

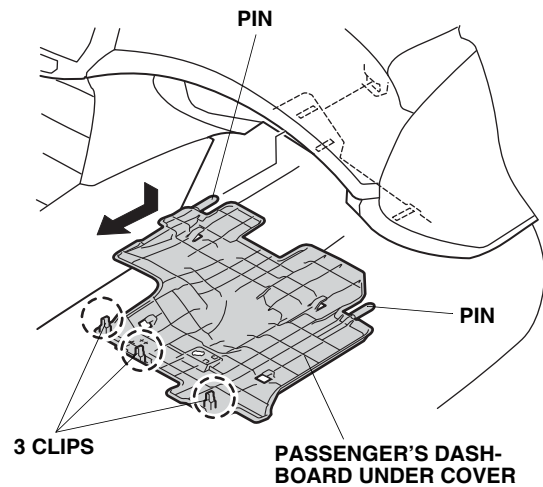

9. Release the glove box (damper rod and two stops).

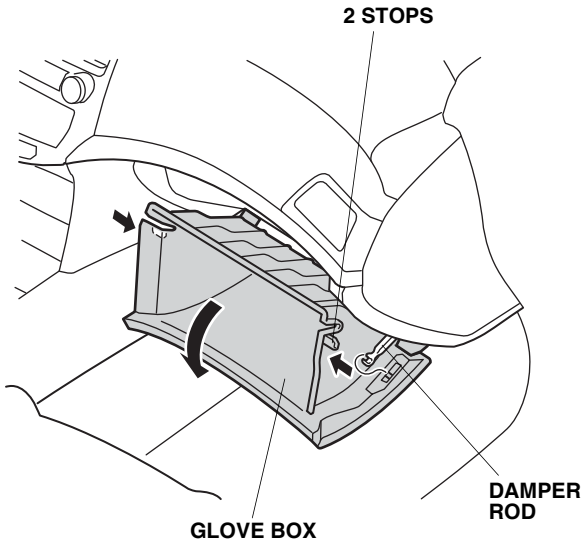

10. Remove the glove box (two screws).

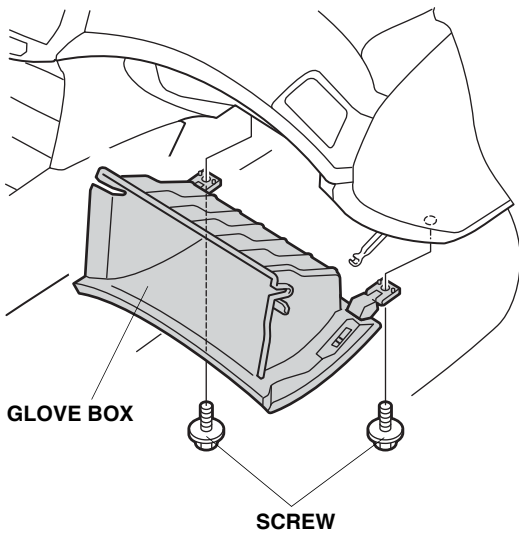

11. Remove three self-tapping screws from the rear of the driver's dashboard lower cover and remove the pocket.

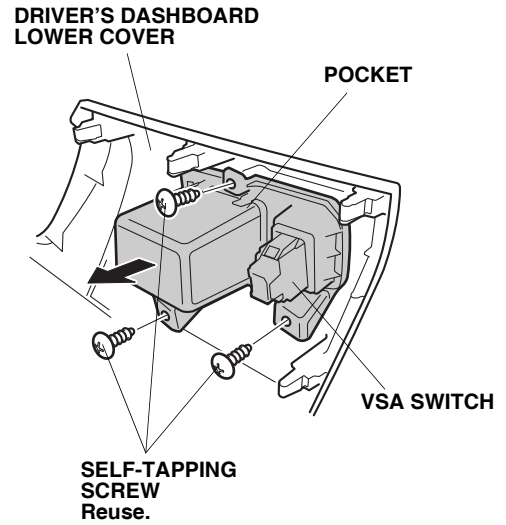

12. Release two retaining tabs and remove the VSA switch from the pocket. Set the pocket aside, it will not be reused.

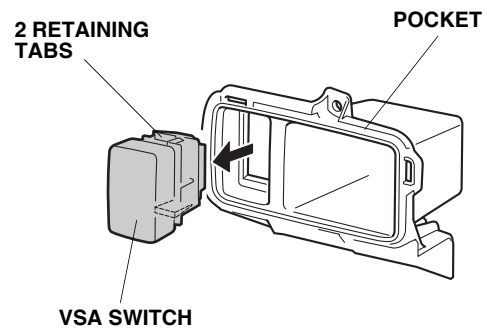

## Installing the Ambient Light Switch

13. Install the VSA switch, removed in step 12, and the ambient light switch into the new switch trim.

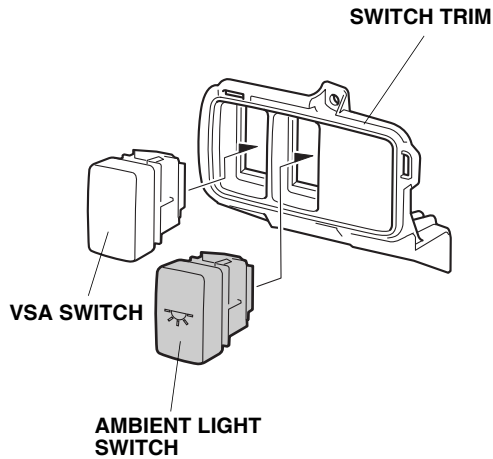

14. Install the switch trim to the driver's dashboard lower cover with the three self-tapping screws removed in step 11.

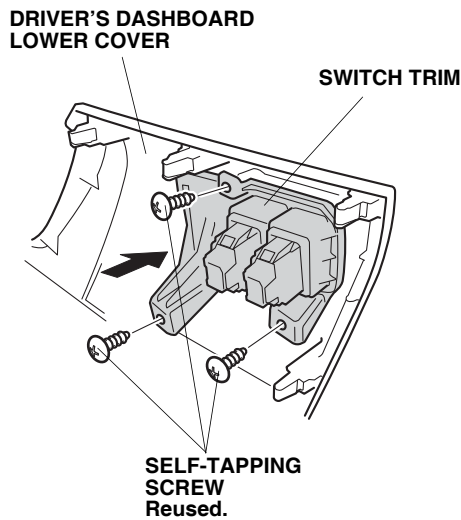

## Routing the Ambient Light Harness

15. Using isopropyl alcohol on a shop towel, thoroughly clean the ambient light harness fuse case where the fuse label will attach. Attach the 2A fuse label to the ambient light harness fuse case.

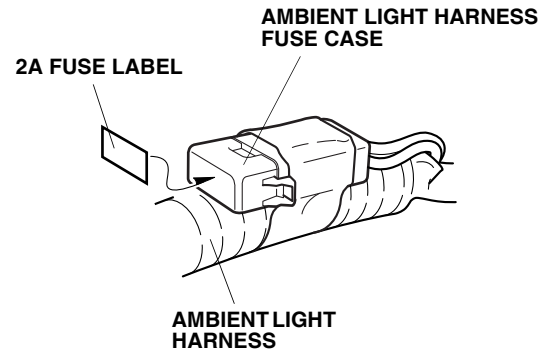

16. Release the VSA harness clip inside the driver's dashboard lower cover opening, .

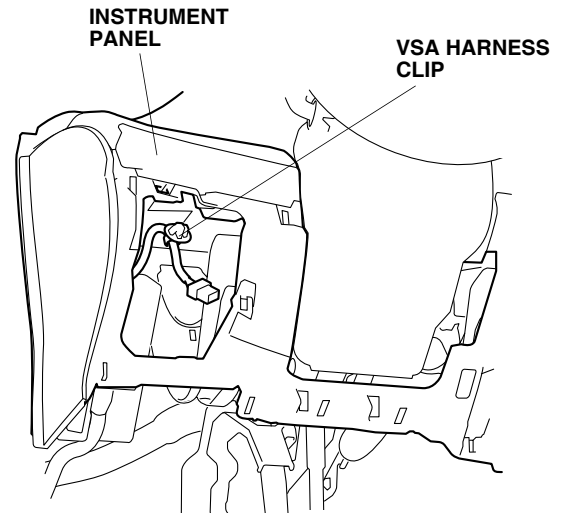

17. On the driver's side of the vehicle, route the ambient light harness 5-pin connectors up to the VSA harness. Secure the clip near the ambient light harness 5-pin connectors to the instrument panel hole where you removed the VSA harness clip.

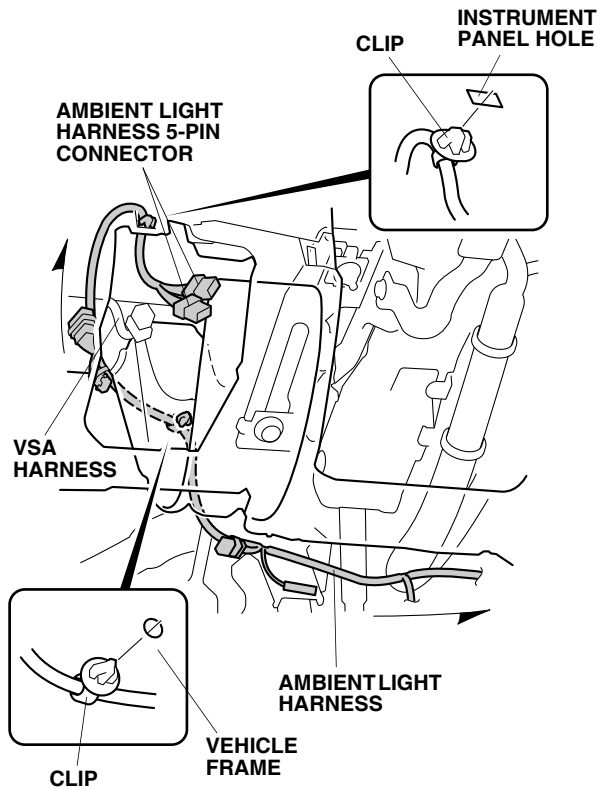

18. Secure the other ambient light harness clip to the hole in the vehicle frame.

19. Plug the VSA harness 5-pin connector to the ambient light harness 5-pin connector.

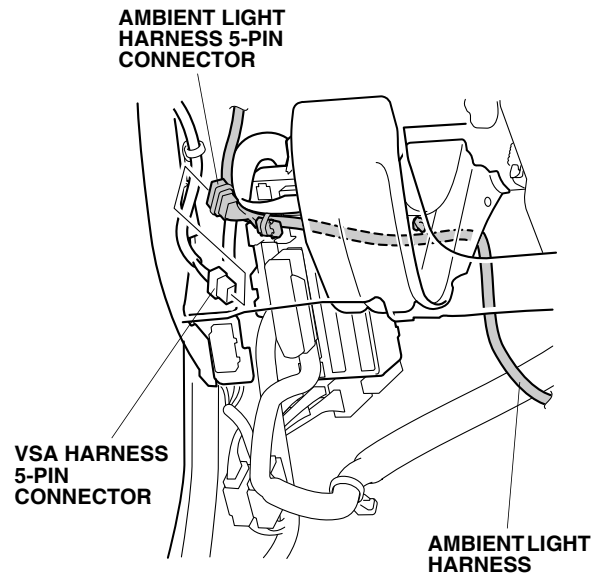

20. Bundle the excess VSA harness with one wire tie.

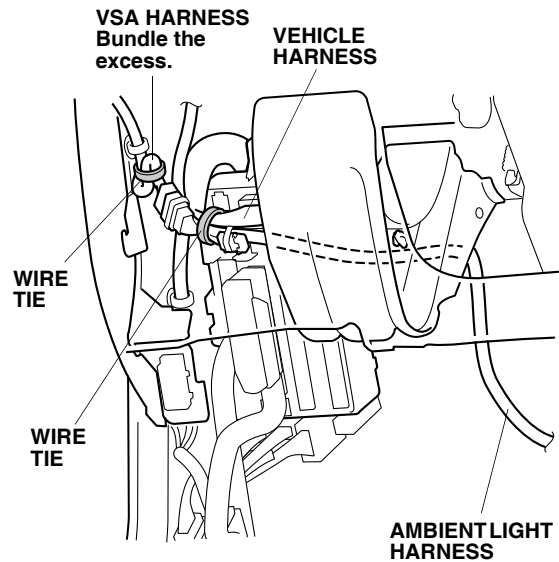

21. Secure the ambient light harness to the vehicle harness with one wire tie.

22. Secure the ambient light harness to the instrument panel with one wire tie.

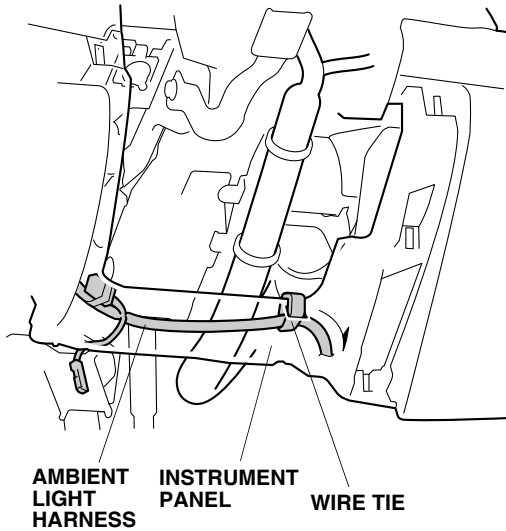

23. Attach a piece of steel wire to the ambient light harness with electrical tape, and route the ambient light harness through the center console from the foot well to the front passenger's foot well.

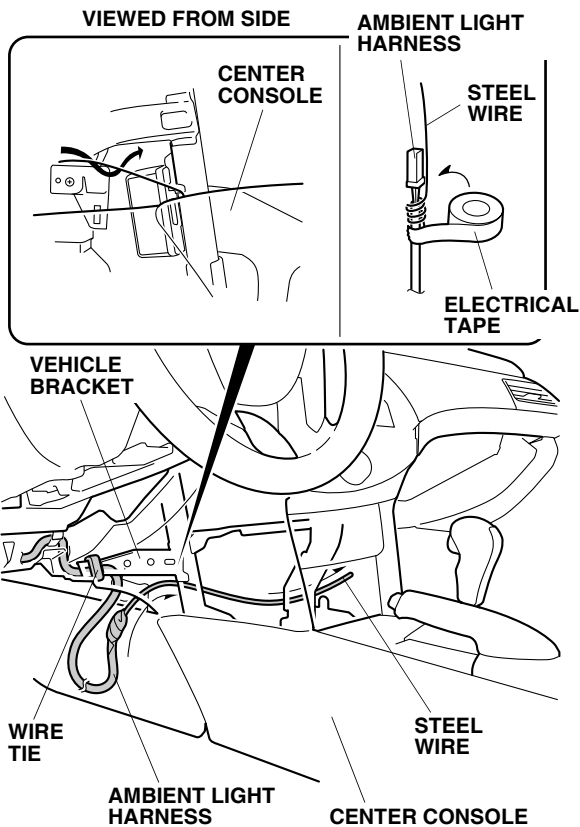

24. Secure the ambient light harness to the vehicle bracket with one wire tie.

25. Remove the electrical tape and steel wire.

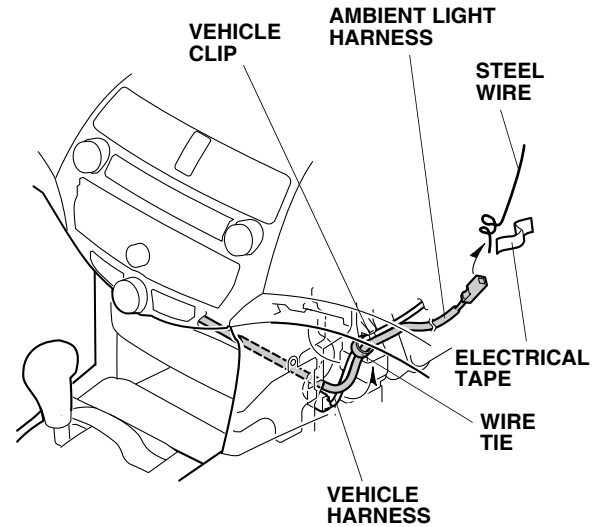

26. Route the ambient light harness and secure the ambient light harness to the vehicle harness with one wire tie as shown.
27. Route the ambient light harness to the glove box opening.

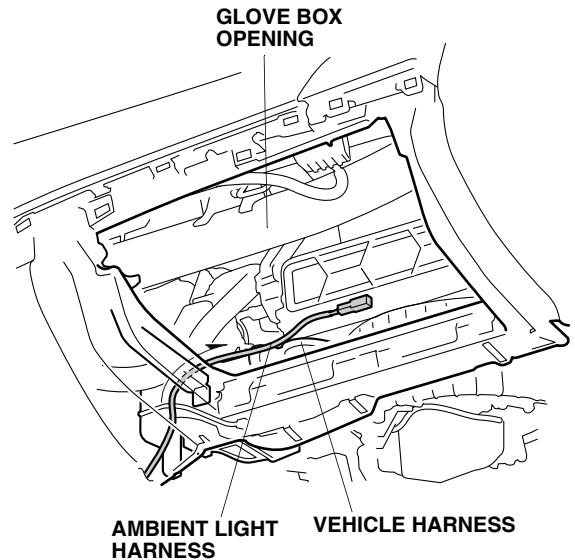

## Installing the Ambient Light

L4 model, go to step 28, V6 model, go to step 30.

### L4 Model

28. Install the ambient light on the driver's side of the vehicle:

- Secure the ambient light to the bracket with one 4 mm flange nut and one 4 x 20 mm pan screw.

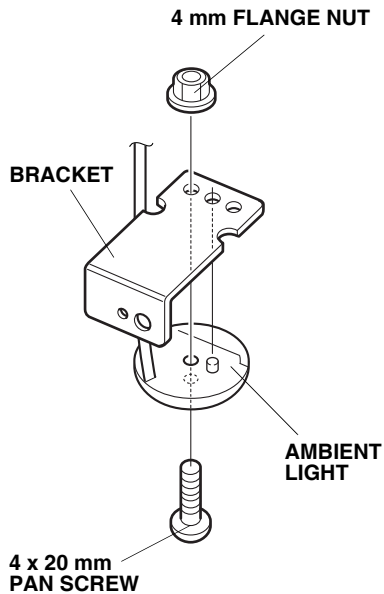

- Install the ambient light to the instrument panel with one 4 x 16 mm self-tapping screw.
- Plug the ambient light 2-pin connector to the ambient light harness 2-pin connector.
- Secure the ambient light harness connector to the bracket with one wire tie with clip.

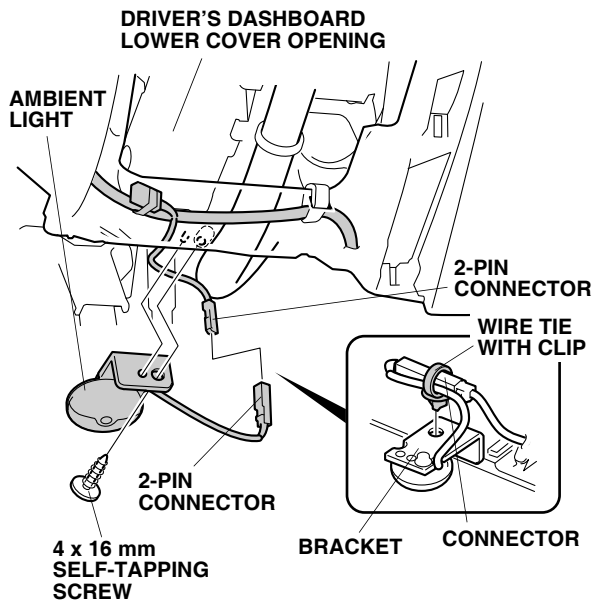

29. Install the ambient light to the passenger's side of the vehicle:

- Using a scissors, cut out the template.

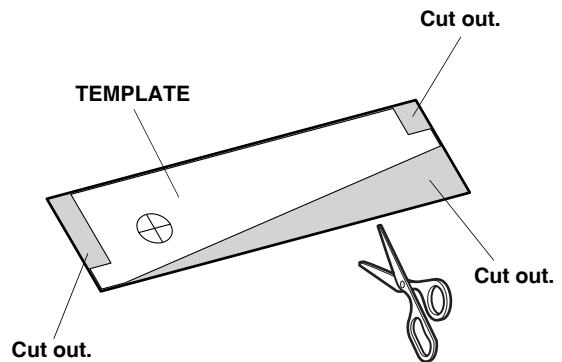

- Under the glove box opening, align the template with the instrument panel.

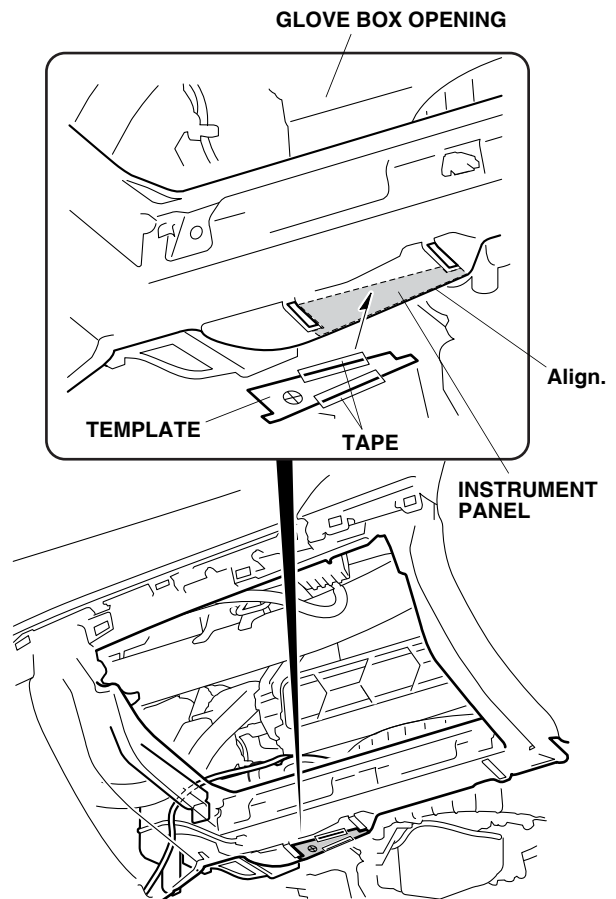

- Using a pushpin, pierce the instrument panel at the mark. Remove the template.

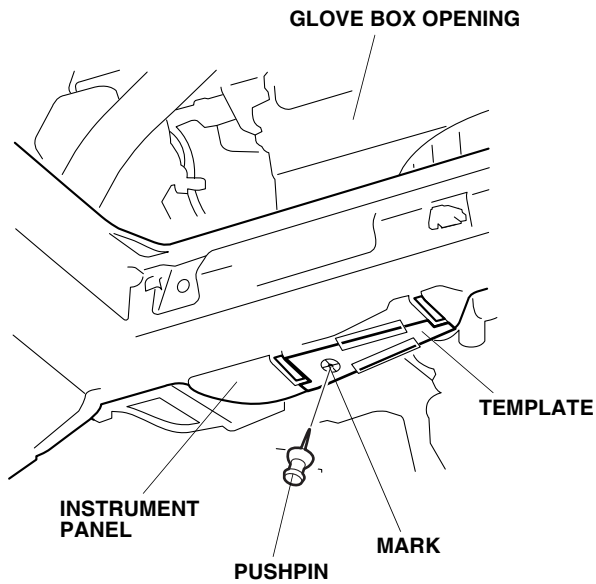

- While wearing eye protection, drill a 7 mm hole through the instrument panel at the pierced mark. First drill with a 3 mm drill bit, then finish with a 7 mm drill bit. Remove any burrs.

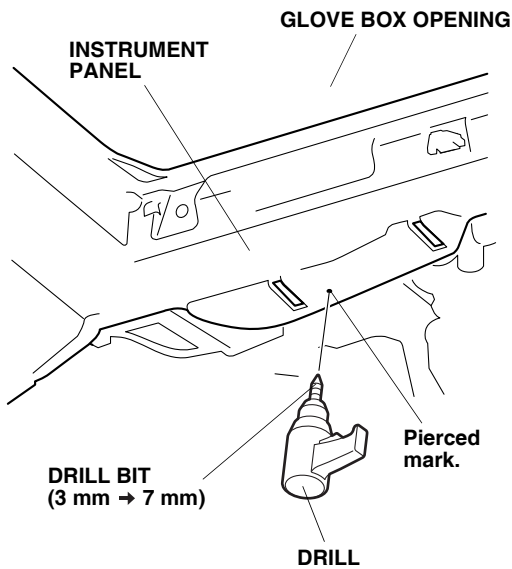

- Secure the ambient light to the bracket with one 4 mm flange nut and one 4 x 20 mm pan screw.

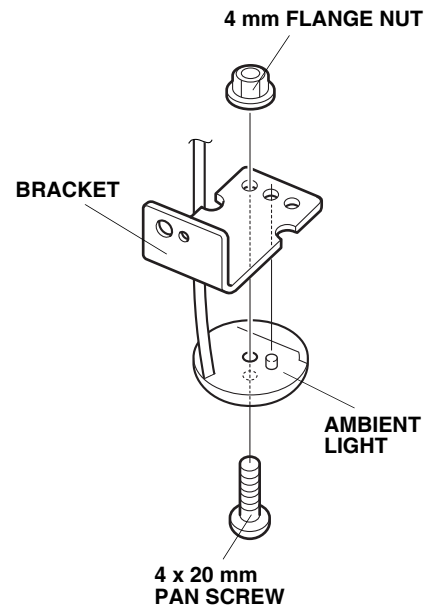

- Secure the ambient light to the instrument panel with one 6 mm flange nut and one 6 x 16 mm washer screw.

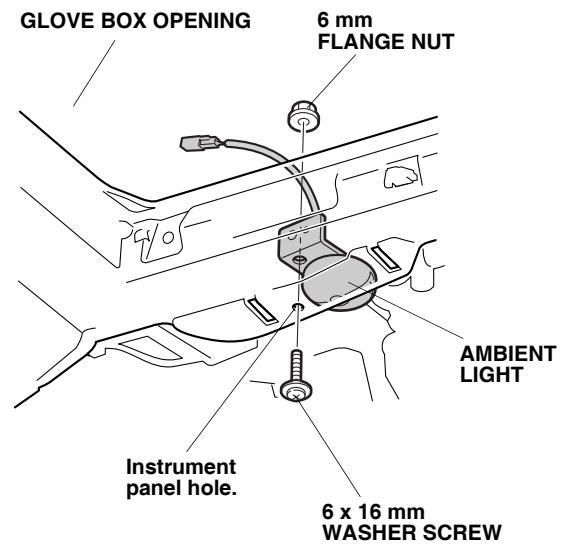

- Plug the ambient light 2-pin connector to the ambient light harness 2-pin connector.
- Secure the ambient light harness to the vehicle harness with one wire tie at the location shown, and secure the 2-pin connector to the vehicle harness with one wire tie.
- Go to step 32.

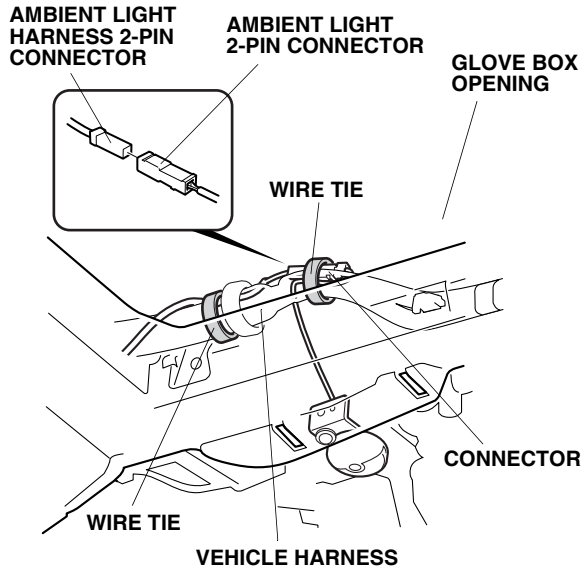

- Using an utility knife, cut out the driver's dashboard under cover as shown.

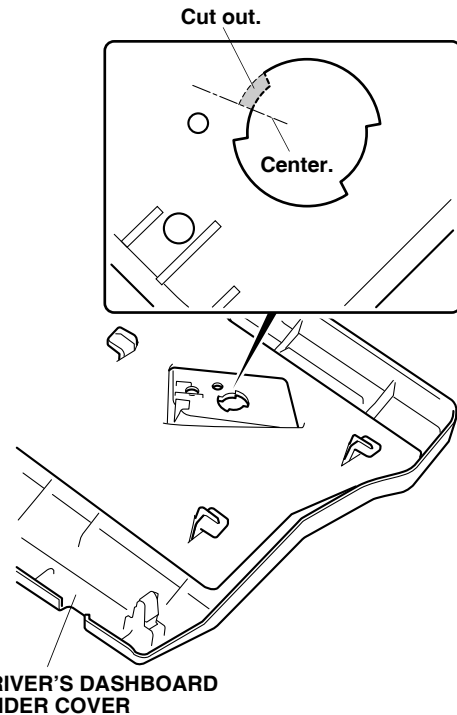

- Route the ambient light 2-pin connector through the 10 mm hole, and attach the ambient light to the driver's dashboard under cover with one 4 x 20 mm pan screw and one 4 mm flange nut through the 5 mm hole.

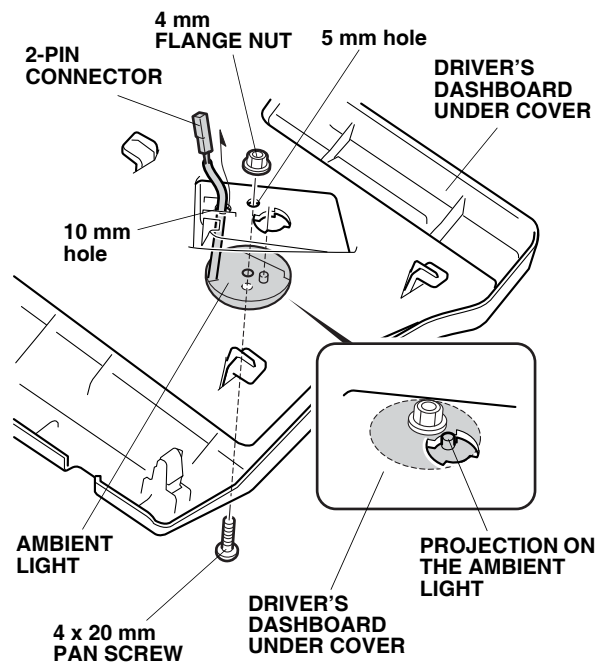

## V6 Model

30. Install the ambient light on the driver's side of the vehicle:
- While wearing eye protection, drill a 5 mm hole and a 10 mm hole in the driver's dashboard under cover at the scribe marks. First drill the right hole with 3 mm drill bit, then finish with a 5 mm drill bit. Drill the left hole with 3 mm drill bit, then finish with a 10 mm drill bit.

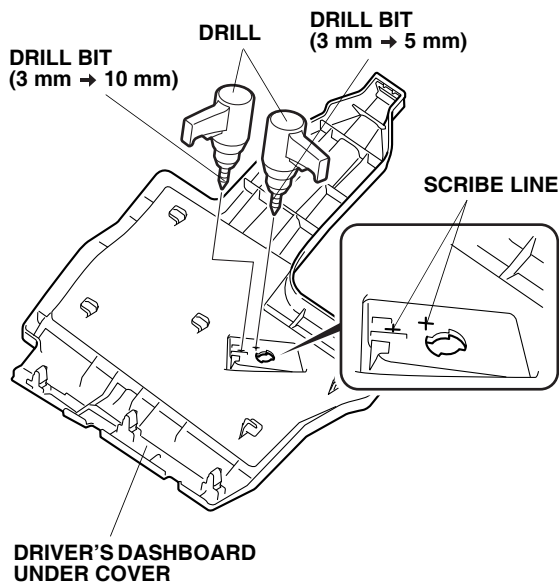

- Install the bracket to the instrument panel with one 4 x 16 mm self-tapping screw.

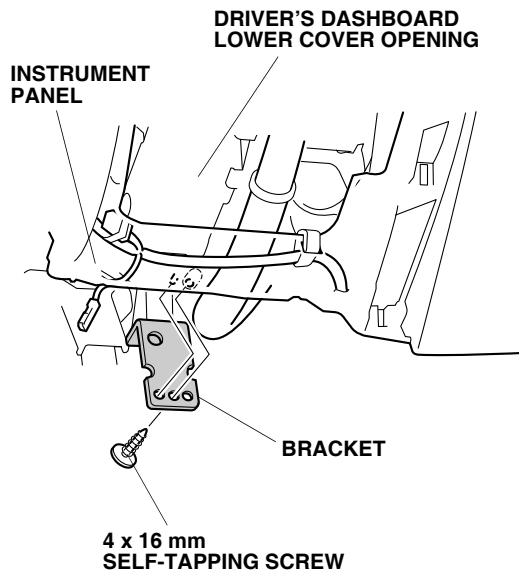

- Plug the ambient light 2-pin connector to the ambient light harness 2-pin connector, and secure the 2-pin connector to the ambient light harness with one wire tie with clip. Then, reinstall the driver's dashboard under cover.

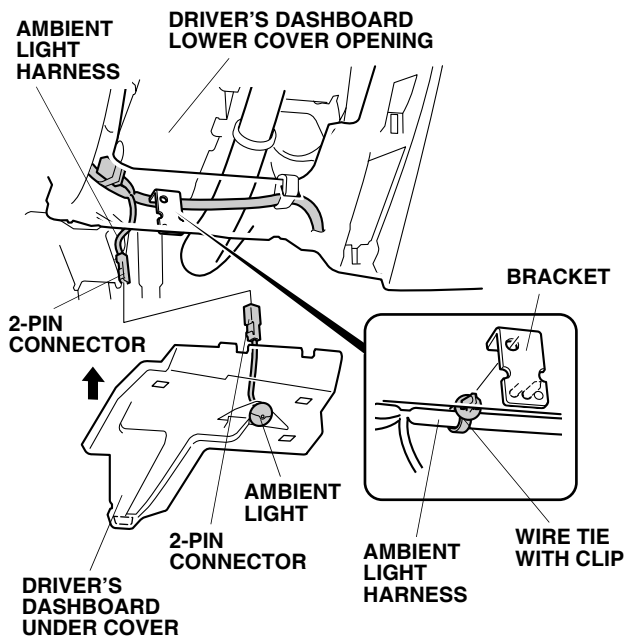

31. Install the ambient light on the passenger's side of the vehicle:

- While wearing eye protection, drill two 5 mm holes and one 10 mm hole in the passenger's dashboard under cover at the scribe marks shown. First drill all of the holes with a 3 mm drill bit, then drill with a 5 mm drill bit. Enlarge the left hole to 10 mm using a 10 mm drill bit.

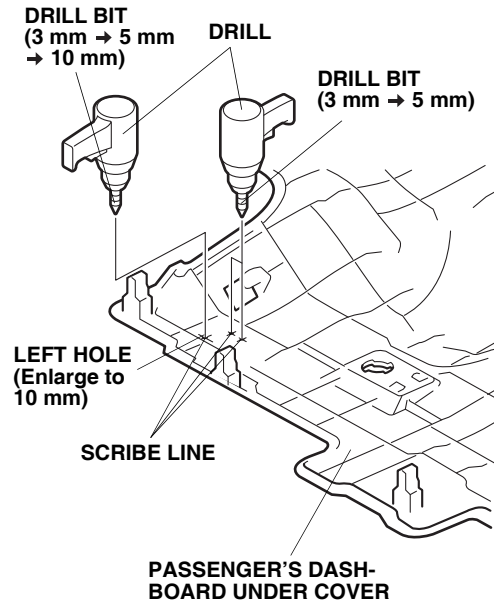

- Route the ambient light 2-pin connector through the 10 mm hole, and attach the ambient light to the passenger's dashboard under cover with one 4 x 20 mm pan screw and one 4 mm flange nut through the 5 mm hole.

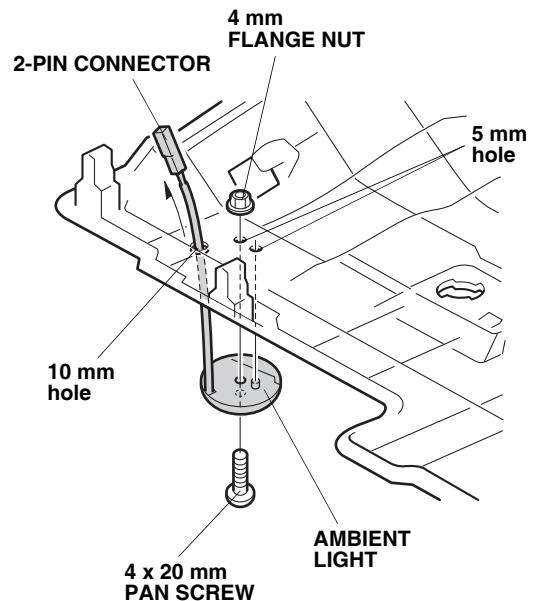

- Plug the ambient light 2-pin connector to the ambient light harness 2-pin connector, and secure the 2-pin connector to the vehicle harness with one wire tie. Then, reinstall the passenger's dashboard under cover.

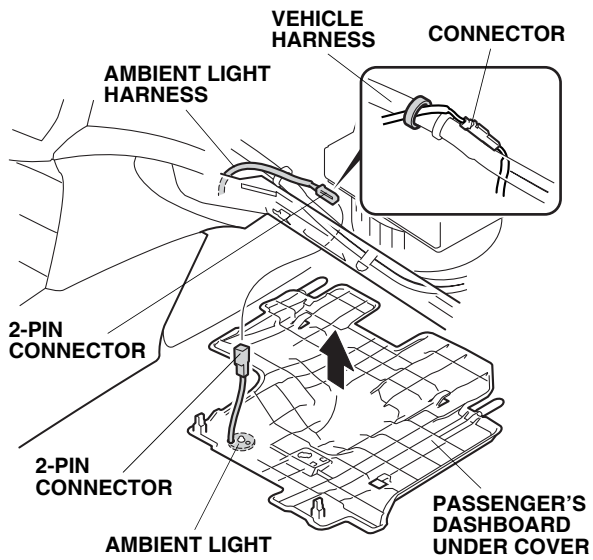



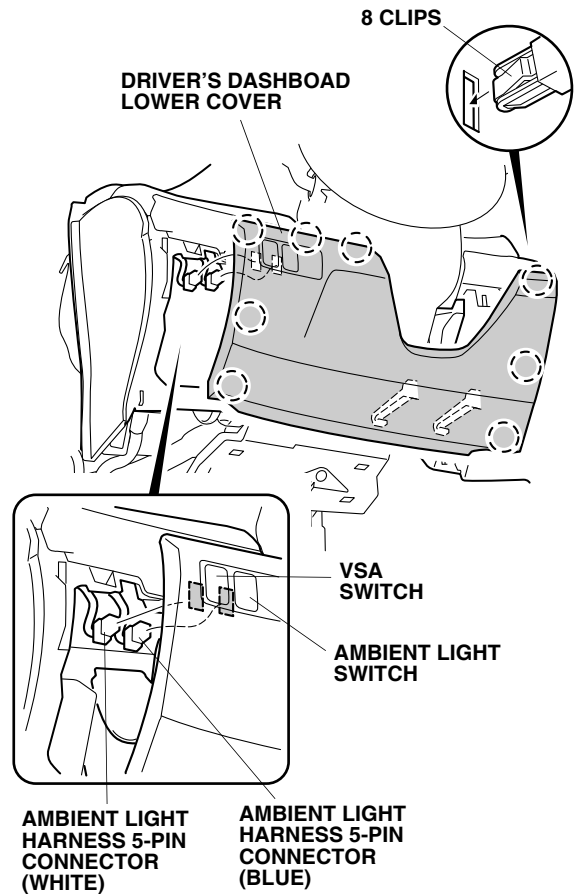

32. Plug the ambient light harness 5-pin connector (blue) to the ambient light switch, plug the ambient light harness 5-pin connector (white) to the VSA switch, and reinstall the driver's dashboard lower cover.



33. Check that all wire harness are routed properly and all connectors are plugged in.
34. Reinstall all removed parts.
35. Reconnect the negative cable to the battery.
36. Enter the anti-theft codes for the radio and navigation if equipped, and reset the radio station presets.
37. Reset the clock on models without navigation.

## HOW TO OPERATE

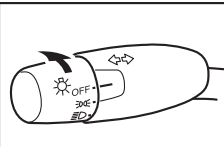
- Turn the light switch to the “” and “” position.
- Press the ambient light switch.
- When the light switch is in the “AUTO” position and ambient light switch is in the “ON” position, the ambient lights are on with the parking lights or headlights.

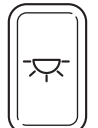
					
		<b>HEADLIGHT SWITCH</b>			
			<b>OFF</b>		
	<b>AMBIENT LIGHT SWITCH</b>	<b>ON</b>	-	<b>ON</b>	<b>ON</b>
		<b>OFF</b>	-	-	-