



**INSTALLATION
INSTRUCTIONS**

Accessory

FULL NOSE MASK
P/N 08P35-TA0-100

Application

2010 ACCORD
4-DOOR

Publications No.

All 42265

Issue Date

AUG 2009

Put this information in the glove box with the vehicle owner's manual.

PARTS LIST

Mask
(Hood section)

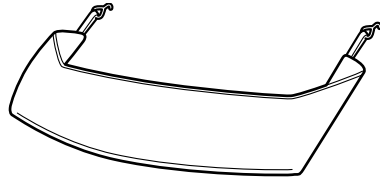

Mask
(Bumper section)

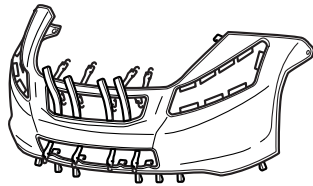

2 Snap-screws



2 Washers



2 Fenderwell nuts



Elastic cord

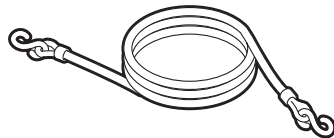

Storage bag

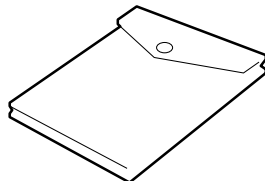

TOOLS AND SUPPLIES REQUIRED

Stubby Phillips screwdriver

Flat-tip screwdriver

INSTALLATION

NOTE:

- Make sure the vehicle and the nose mask are clean and completely dry before installation. If moisture under the mask is allowed to dry, it may cloud the paint. If the mask gets wet, remove it and allow it to air-dry completely.
- Make sure any repainted surfaces are cured.
- Make sure the hood and nose of the vehicle have been waxed with a high-quality paste wax.
- Make sure to install the nose mask securely. If the nose mask starts to flap or comes loose while driving, safely pull off the highway, stop the vehicle, and secure or remove the mask.

Displaying the License Plate

If your state law requires the display of both license plates, cut out the piece of the bumper section that covers the front license plate:

- Face the inside of the mask toward you.
- Carefully cut out the license plate section with scissors at the top seam, and remove the overcast stitching.

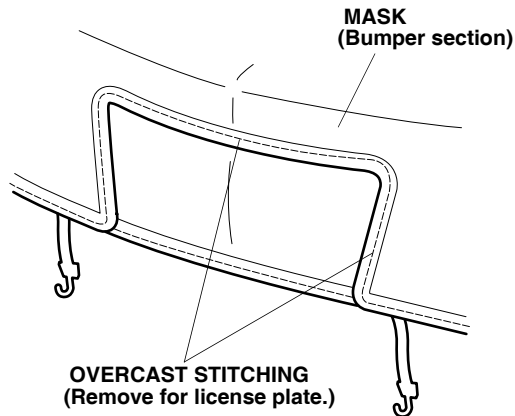

With Fog Lights

If the vehicle you are working on is equipped with fog lights, cut out the piece of the bumper section that covers the fog lights:

- Face the inside of the mask toward you.
- Carefully cut out the fog lights section with scissors at the top seam, and remove the overcast stitching.

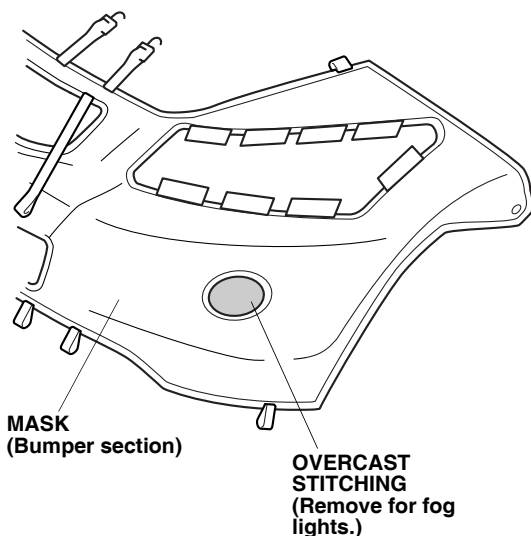

Installing the Hood Section

1. Open the hood. Fit the corners of the mask (hood section) around the hood and adjust the mask so that it fits smoothly over the edges. Attach the S-hooks to the hood. Remove / install the S-hooks by inserting your finger into the belt of each S-hook. Pulling the S-hooks with excessive force can break the S-hook strap.

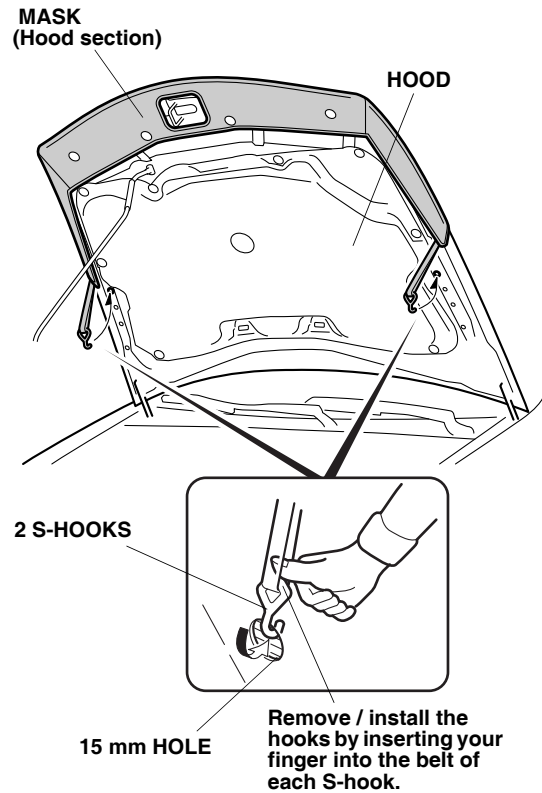

Installing the Bumper Section

2. Turn the steering wheel all the way clockwise.
3. Pry out the second plastic pin from the front, and remove the expansion clip that fastens the inner fender, remove and retain the clip, then clean the area around the hole.

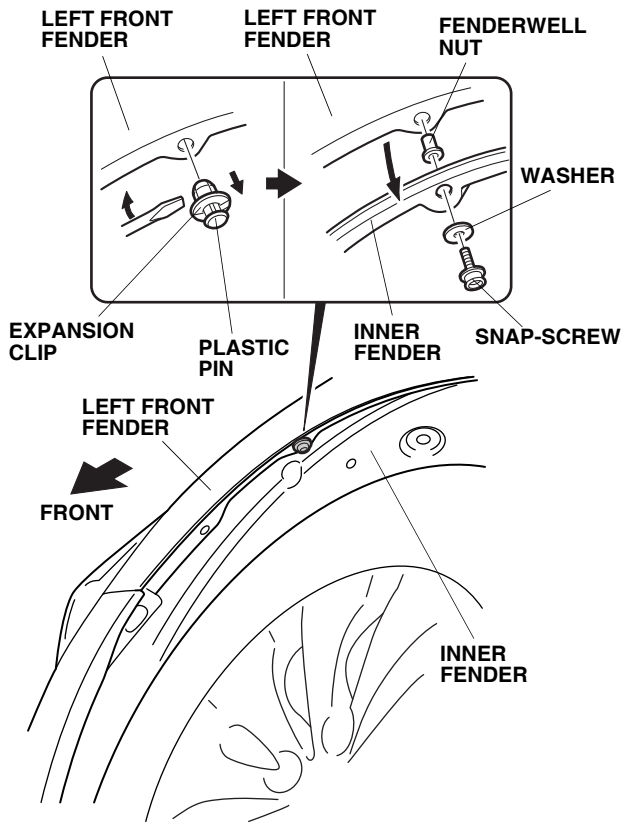

4. Pull the inner fender out, and press one fenderwell nut into the hole in the fender flange.
5. With its washer in place, securely tighten one snap-screw into the fenderwell nut.
6. Turn the steering wheel all the way counter clockwise, and repeat steps 3 thru 5 on the right side.

7. Attach a hook to the left side engine cover. Repeat on the right side.

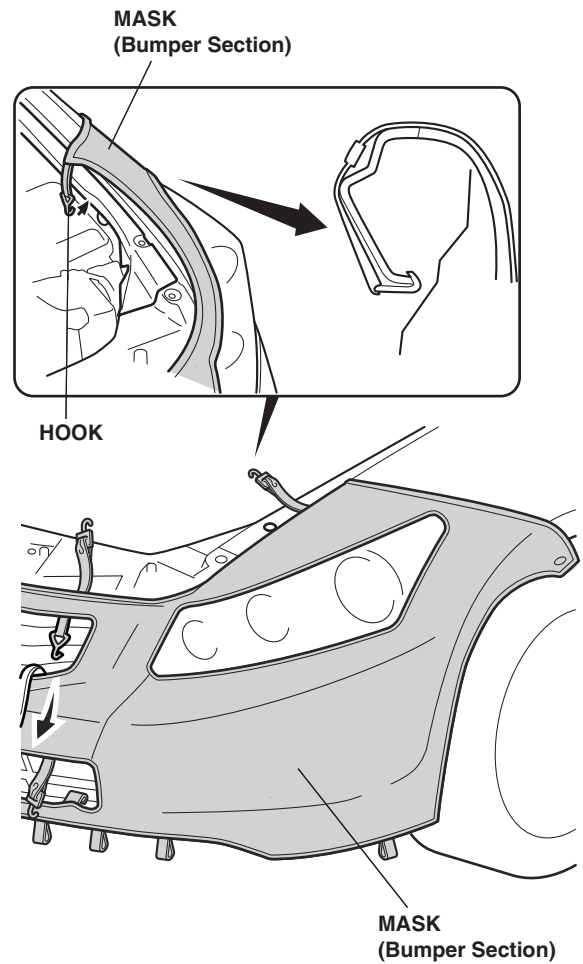

8. Pull the mask (bumper section) back toward the wheelwell, smooth out any wrinkles, and then snap the mask (bumper section) onto the snap-screw.

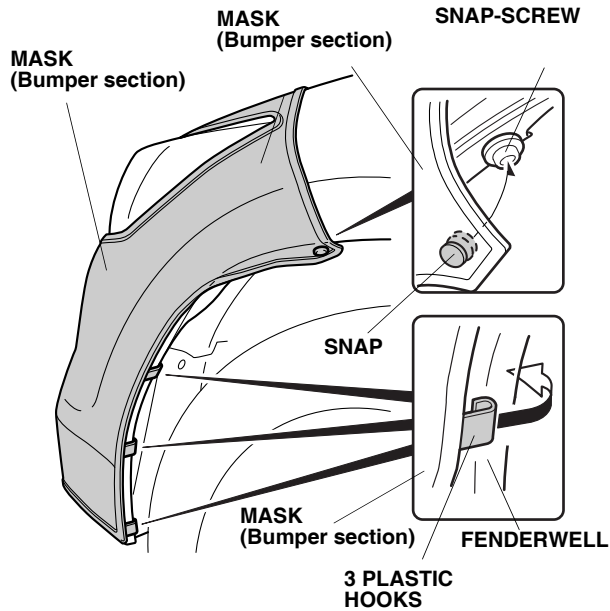

9. On both sides of the vehicle, attach the three plastic hooks to the fenderwell. Repeat on the right side.
10. Insert the eight tabs between the headlight. Repeat on the right side.

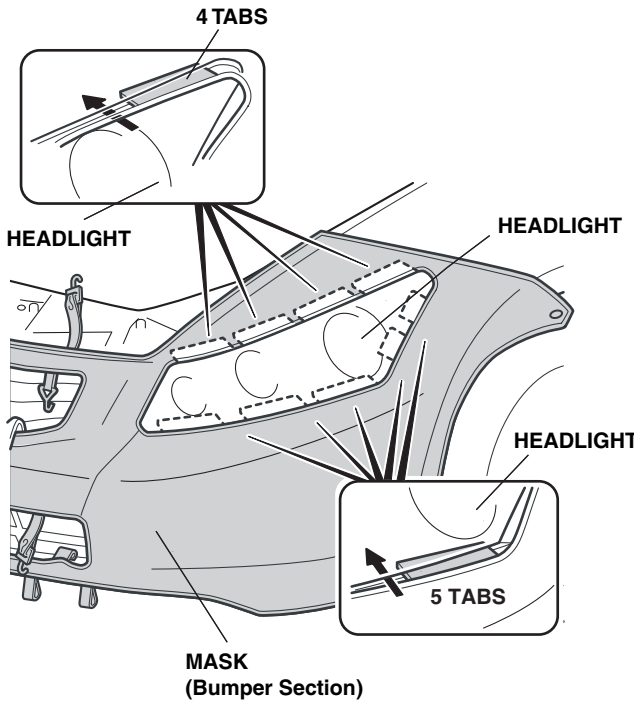

11. Attach the four hooks to the bottom edges of the bumper grille.

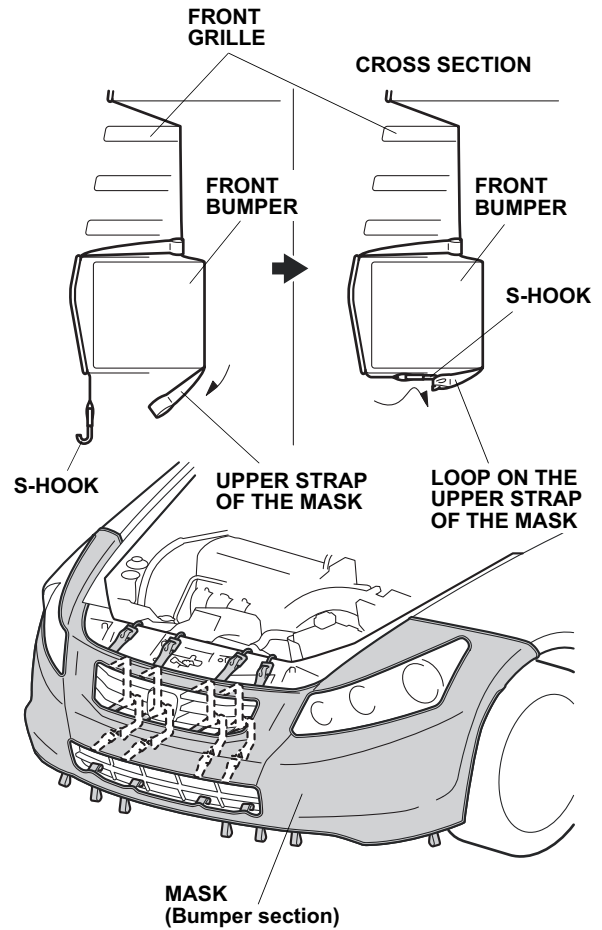

12. Route the four straps through the openings in the upper grille area, and down behind the bumper.

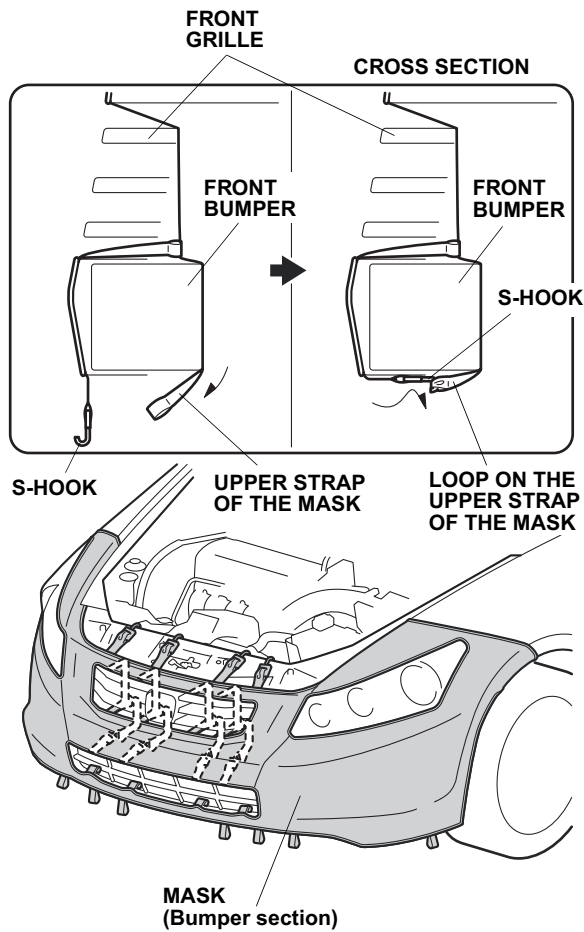

13. Reach under the lower grille and pull the straps out. Attach the four straps to the four hooks on the bottom of the mask.

14. Attach the four S-hooks to the bottom inside edge of the radiator cover.

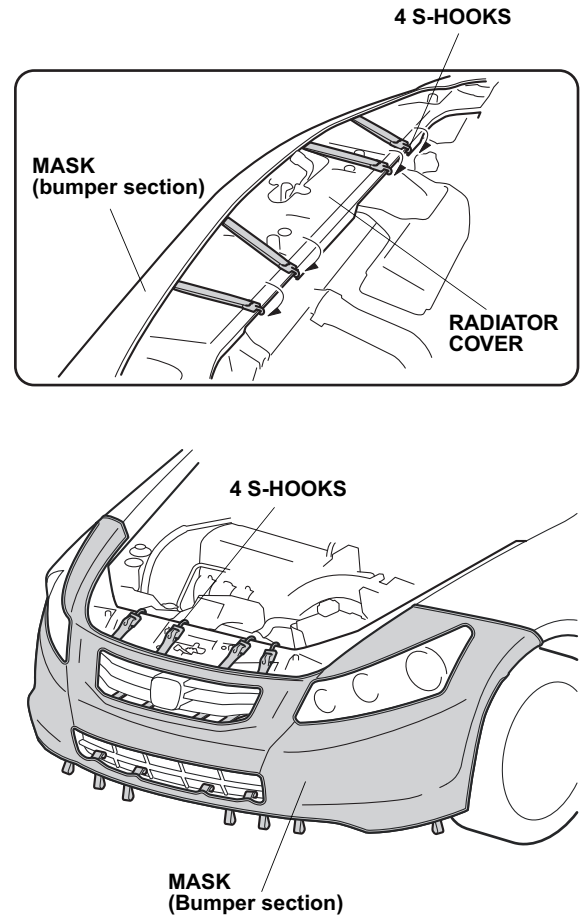

15. Attach the four plastic hooks to the bottom inside edge of the front bumper.

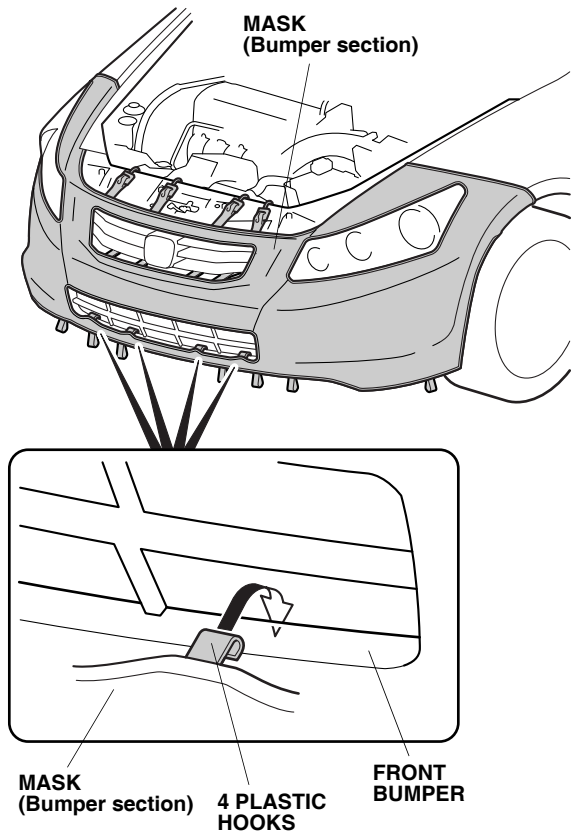

16. Route the elastic cord through the eight loops on the bottom of the mask. Attach one S-hook to the hole of the inner fender. Stretch out the cord after routing it through each loop then attach the other S-hook to the hole of the inner fender to the other side.

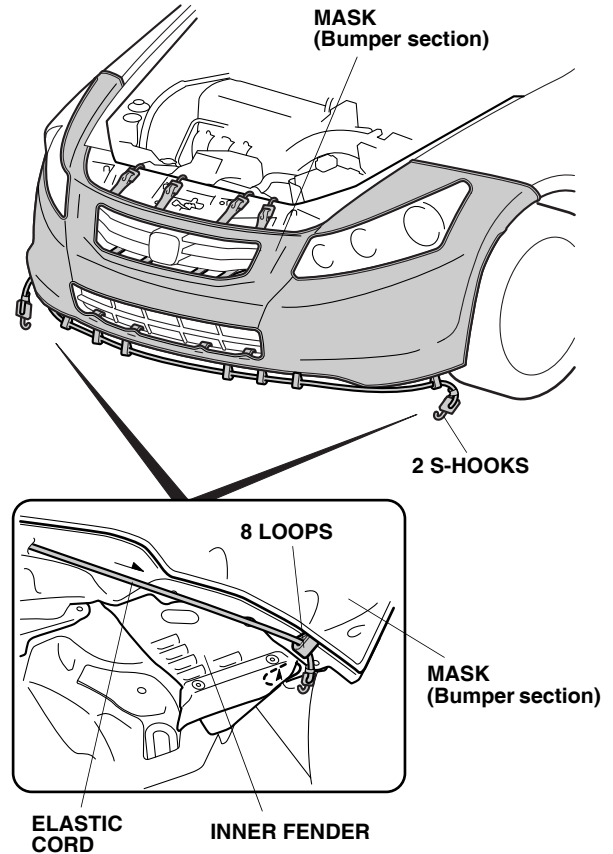

CLEANING THE NOSE MASK

Use a sponge or cloth and a solution of mild liquid dishwashing soap and water to clean the vinyl and the flannel backing. Rinse the mask completely with clean water, and hang it to dry out of direct sunlight. Make sure the mask is completely dry before you reinstall it.