



**INSTALLATION
INSTRUCTIONS**

Accessory
CARGO NET
P/N 08L96-TA0-100

Application
2010 ACCORD
2-AND 4-DOOR

Publications No.
All 42241

Issue Date
AUG 2009

PARTS LIST

Cargo net

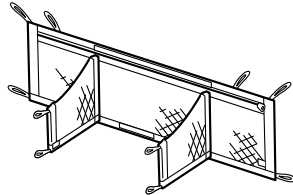

2 Anchors A (Large)



8 Anchors B (Small)



4 Stud bolts



4 Rivet nuts



6 Hex bolts, 6 x 16 mm



2 Flange nuts, 6 mm



8 Plain washers, 6 mm



4 Spring washers, 6 mm



2 Spacers



Template A (4-door)

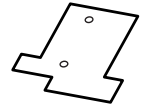

Template B (2-door)

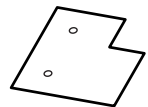

Template C (2-door)

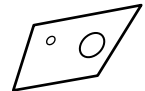

Accessory User's Information Manual

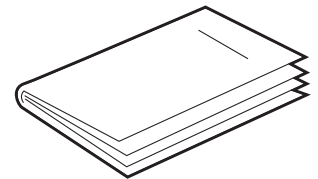

TOOLS AND SUPPLIES REQUIRED

- Clip remover
- Rivet nut tool
- Hex wrench
- 27 mm wrench
- Drill
- 3 mm, 6.5 mm, 8 mm, 9 mm, and 11 mm Drill bits
- Eye protection
- Pushpin
- Round file
- Center punch
- Masking tape
- Tape
- Touch-up paint
- Torque wrench

INSTALLATION

4-door model: Perform step 1 through 32.

2-door model: Perform step 33 through 69.

Removing the Vehicle Parts

1. Remove the trunk floor mat (one clip).

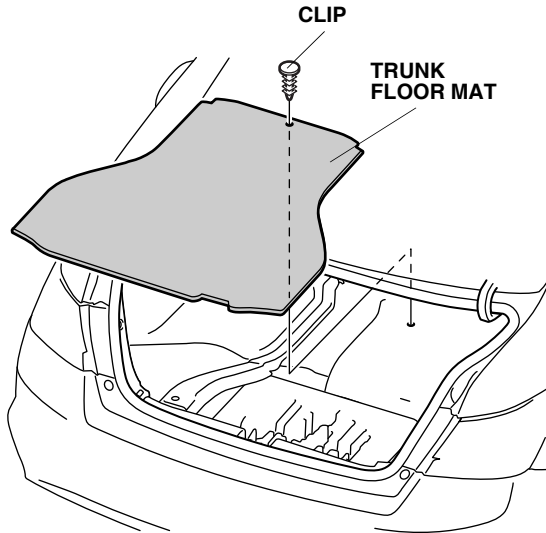

2. Remove the rear trim panel (four clips and three hooks).

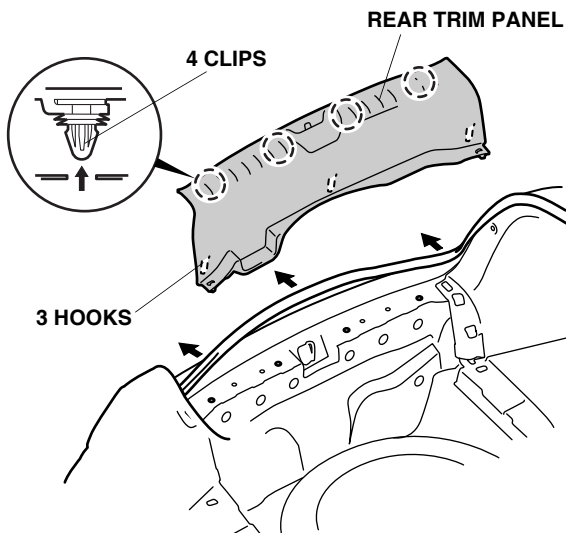

3. Remove the left trunk side lining (five clips).
4. Remove the right trunk side lining the same way.

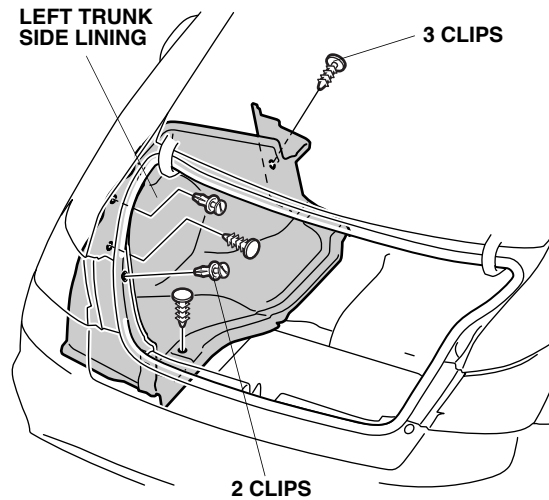

Installing the Anchors

5. Wearing eye protection, use a drill to enlarge the two clip holes to 9 mm.
 - Wrap tape around the drill bit at 15 to 20 mm from the tip of the bit.
 - Remove any burrs from the edge of the holes using a round file. Apply touch-up paint to the drilled surface and allow the paint to dry thoroughly.
6. Repeat the step 5 on the right side.

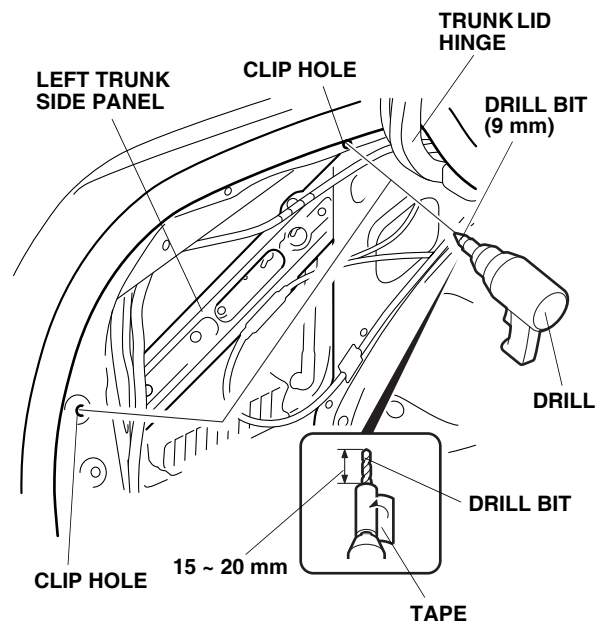

7. Thread the rivet nut onto the mandrel of the rivet nut tool as shown.

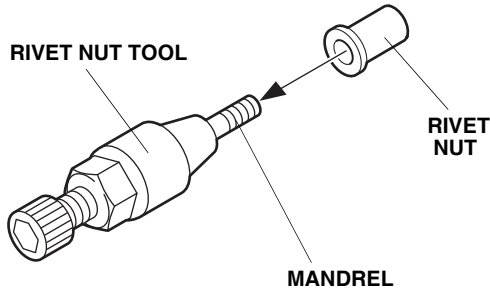

8. Insert the two rivet nuts into the hole in the left trunk side panel and install the hex wrench on the rivet nut tool.

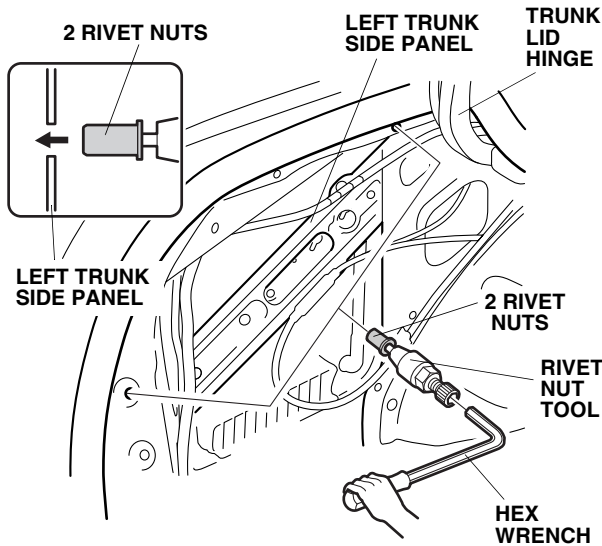

9. While holding the rivet tool with the hex wrench, turn the 27 mm wrench clockwise and install the two rivet nuts to the left trunk side panel.
10. Remove the rivet nut tool from the two rivet nuts by turning the hex wrench counterclockwise.
11. Repeat the steps 7 through 10 on the right side.

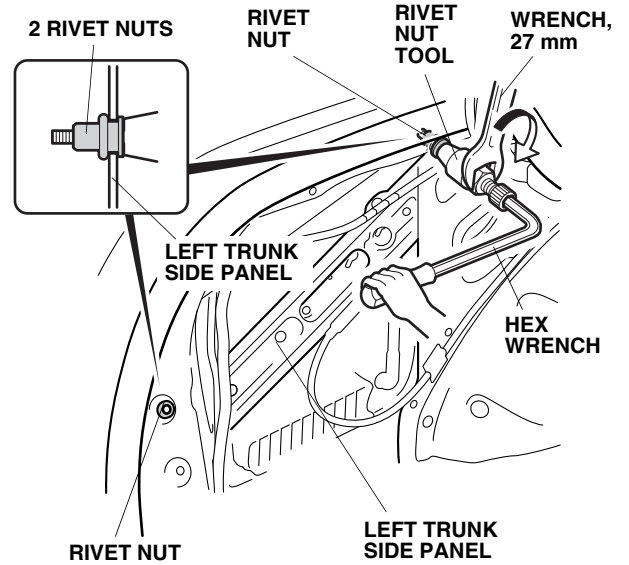

12. Insert the 6 x 16 mm hex bolt, into the hole in the left trunk side panel, and install two 6 mm plain washers and a 6 mm flange nut. Torque the 6 x 16 mm hex bolt to 9.8 N·m (1 kgf·m, 7.2 lbf·ft)
13. Repeat the step 12 on the right side.

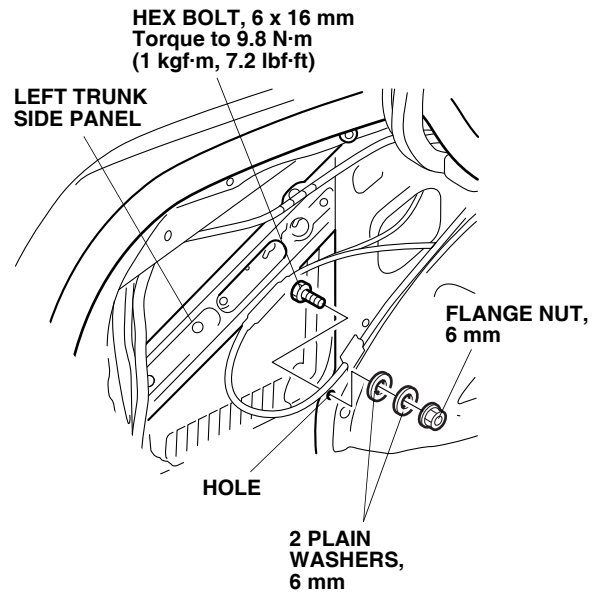

14. Using a pushpin to mark the scribe mark on the rear of the left trunk side lining.
15. While wearing eye protection, drill at the marked point using a drill with 3 mm bit first, finish with 11 mm bit.
16. Repeat the steps 14 and 15 on the right side.

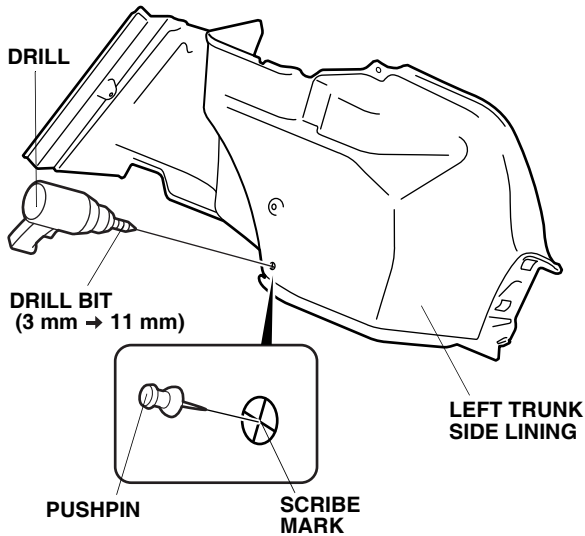

17. Assemble the stud bolt on the anchor B (Small).

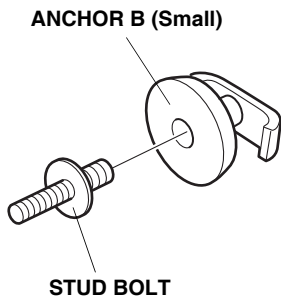

18. Assemble the spacer and the stud bolt on the anchor B (Small).

NOTE: The direction of the spacer.

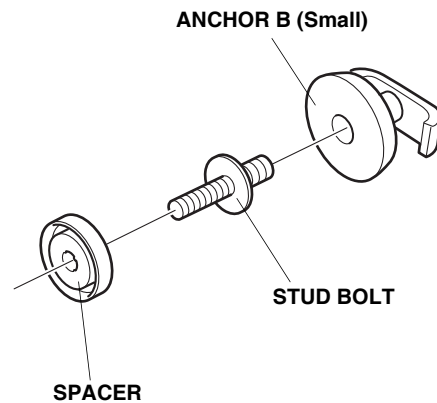

19. Reinstall the left trunk side lining (five clips).
20. Install the anchor B (Small) assembled in step 17 and 18 into the rivnut installed in step 9.
21. Install the anchor A (Large) to the 6 x 16 mm hex bolt as shown. Position the anchors in the same ways as shown.
22. Repeat the steps 17 through 21 on the right side.

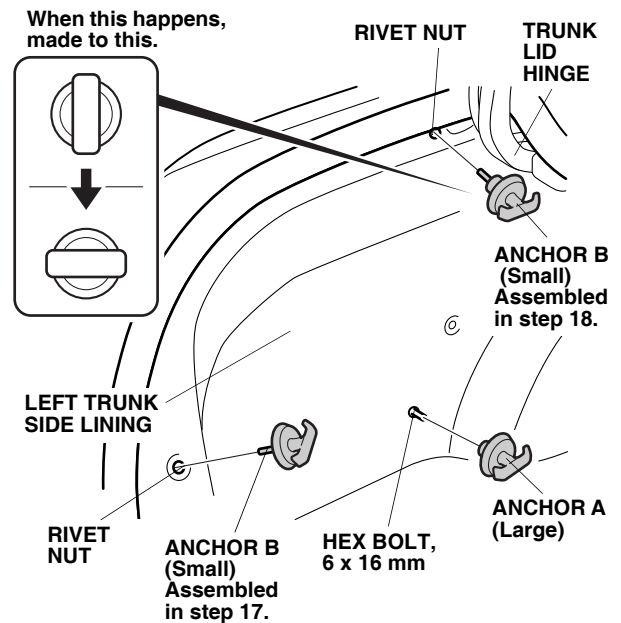

23. Attach the template A to the rear of the rear trim panel using masking tape.
24. Mark the rear of the rear trim panel with a pushpin according to the two template A marks. Remove the template A.

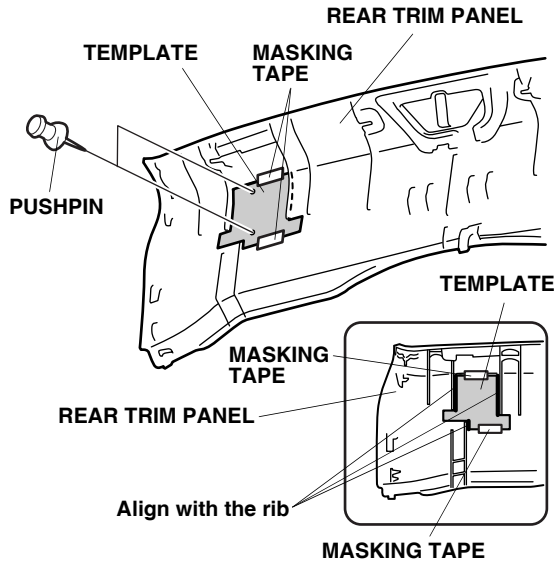

25. Reverse the template A. Attach it to the rear of the rear trim panel using masking tape.
26. Mark the rear of the rear trim panel with a pushpin according to the two template A marks. Remove the template A.

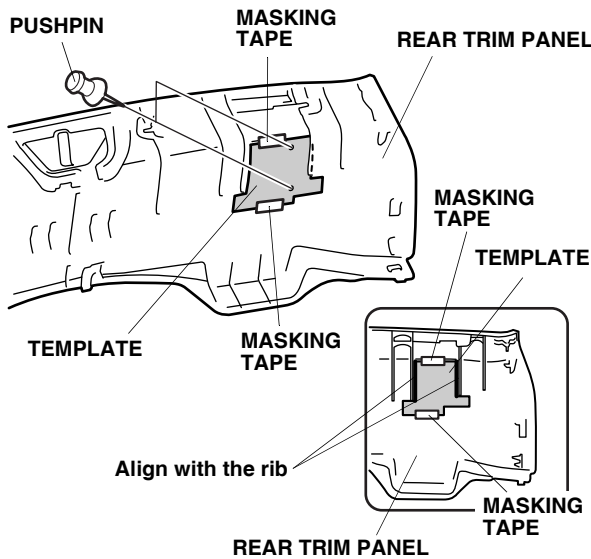

27. While wearing eye protection, drill at the marked points using a drill with 3 mm bit first, finish 6.5 mm bit. Remove any burrs from the edge of the holes using a round file.

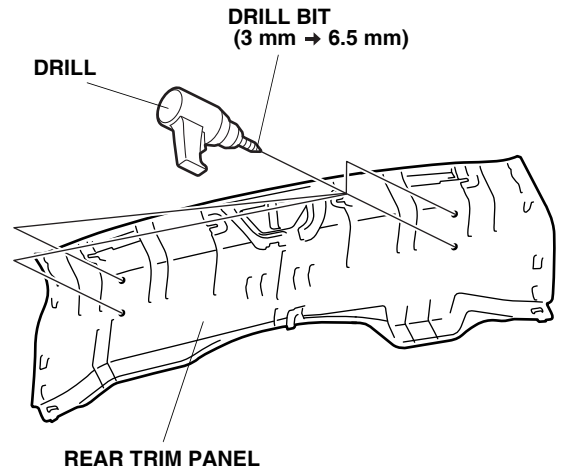

28. Install the four anchors B (Small) with four 6 x 16 mm hex bolts, four 6 mm spring washers, and four 6 mm plain washers to the rear trim panel as shown. Torque the 6 x 16 mm hex bolts to 5 N·m (0.5 kgf·m, 3.7 lbf·ft). Position the anchors in the same ways as shown.
29. Reinstall the rear trim panel (four clips and three hooks).

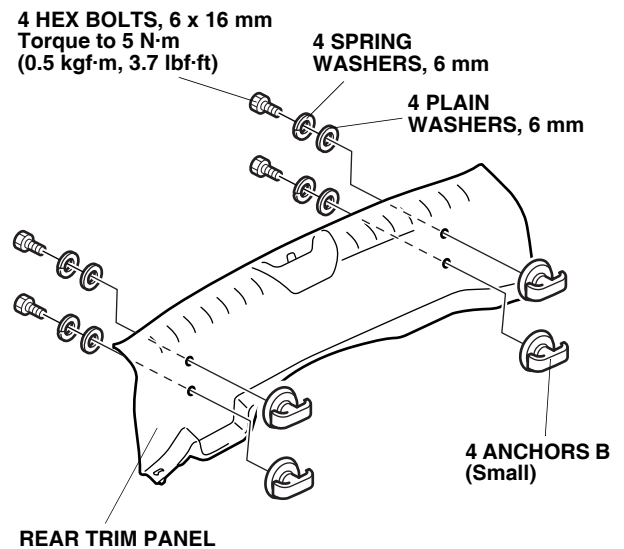

Installing the Cargo Net

Vertical position

30. Hook the loops on the cargo net around the anchors A (Large) and B (Small).

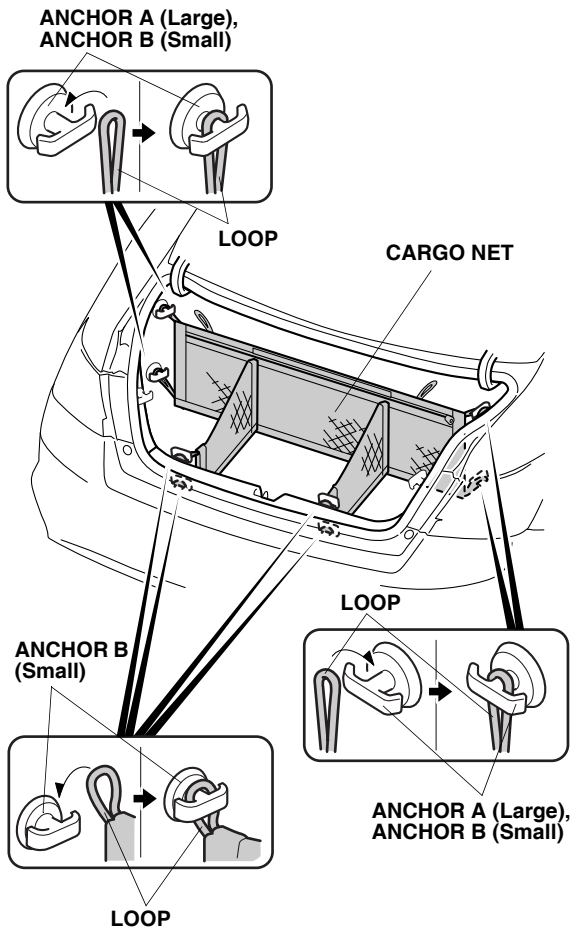

Rear vertical position

31. Attach the magic-fastener as shown on the cargo net.

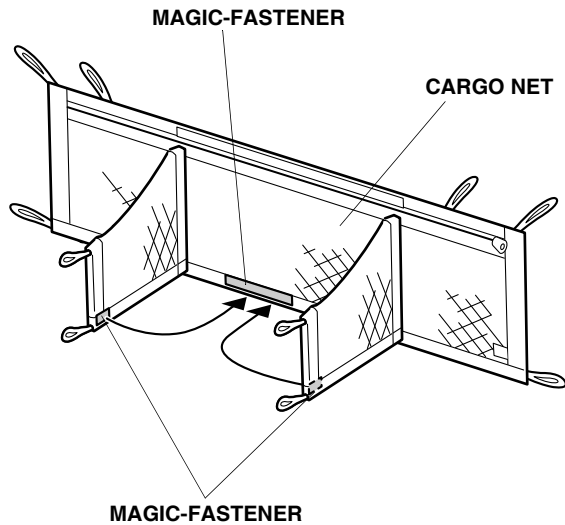

32. Hook the loops on the cargo net around the anchors A (Large). Make sure that the reflector tape is visible after installing.

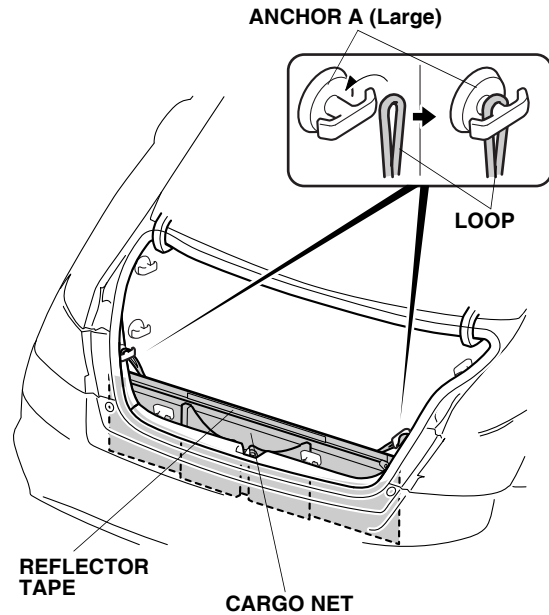

2-door model: Perform step 33 through 69.

Removing the Vehicle Parts

33. Remove the trunk floor mat (one clip).

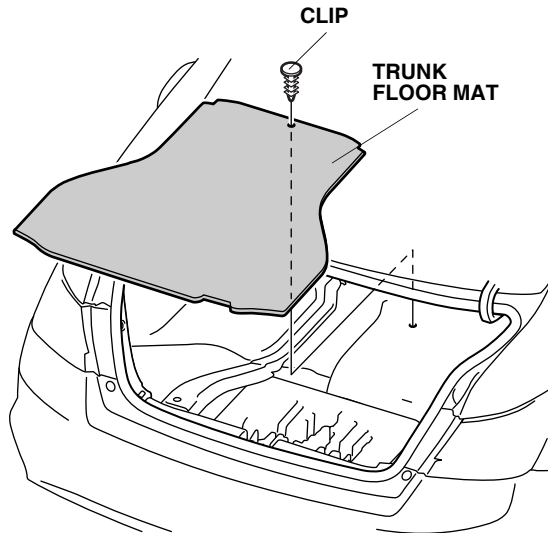

34. Remove the rear trim panel (five clips and three hooks).

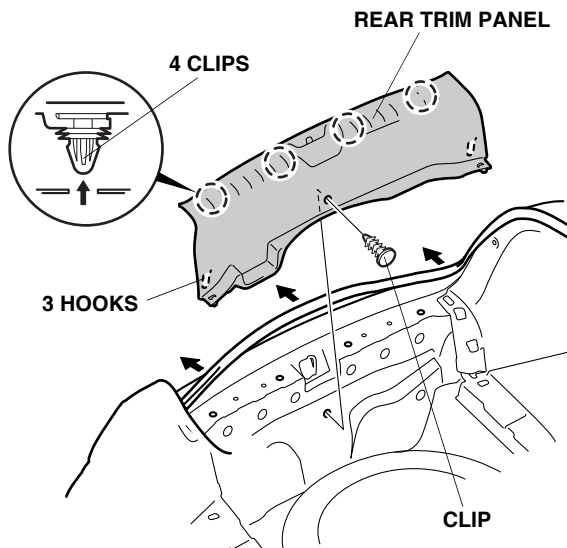

35. Remove the left trunk side lining (five clips).

36. Remove the right trunk side lining the same way.

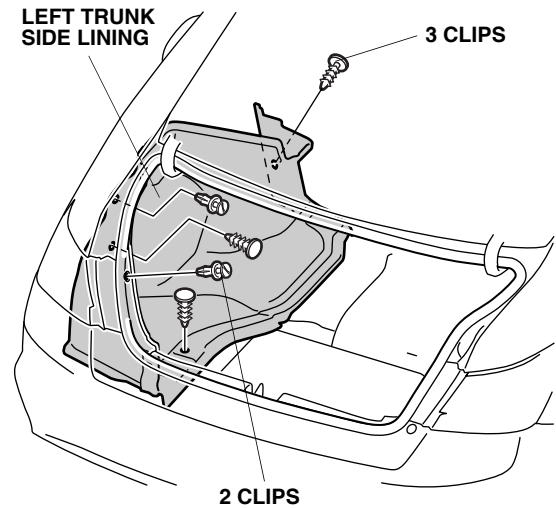

Installing the Anchors

37. Wearing eye protection, use a drill to enlarge the clip hole to 9 mm.

- Wrap tape around the drill bit at 15 to 20 mm from the tip of the bit.
- Remove any burrs from the edge of the holes using a round file. Apply touch-up paint to the drilled surface and allow the paint to dry thoroughly.

38. Repeat the step 37 on the right side.

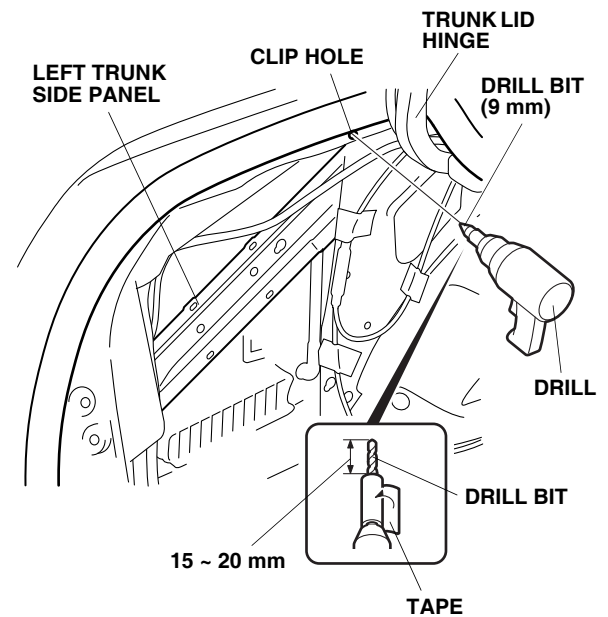

39. Thread the rivet nut onto the mandrel of the rivet nut tool as shown.

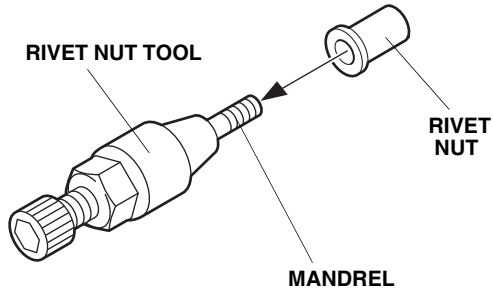

40. Insert the two rivet nuts into the hole in the left trunk side panel and install the hex wrench on the rivet nut tool.

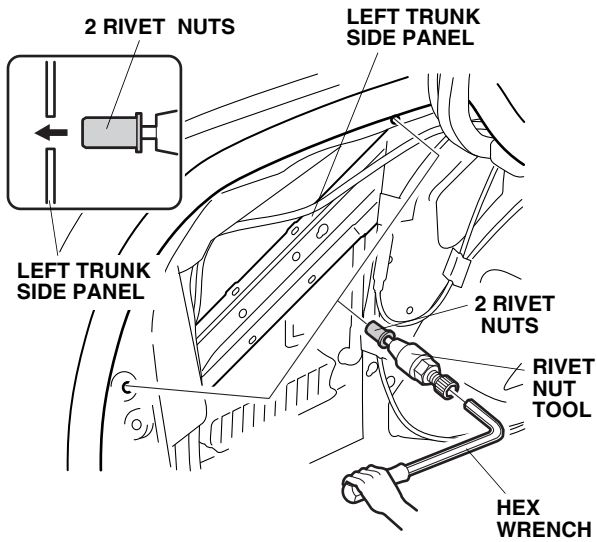

41. While holding the rivet tool with the hex wrench, turn the 27 mm wrench clockwise and install the two rivet nuts to the left trunk side panel.
42. Remove the rivet nut tool from the two rivet nuts by turning the hex wrench counterclockwise.
43. Repeat the steps 39 through 42 on the right side.

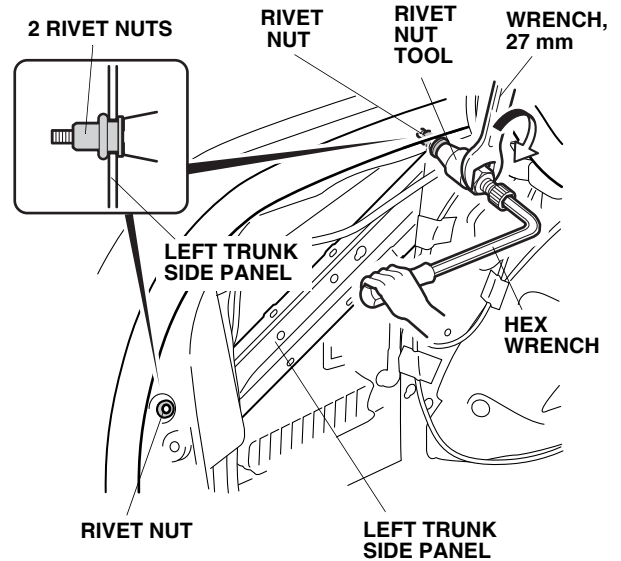

44. Attach the template C to the left trunk side panel using masking tape.
45. Center punch at the marked point on the template C. Remove the template C.
46. While wearing eye protection, drill at the marked point using a drill with 3 mm bit first, finish with 6.5 mm bit.
 - Wrap tape around the drill bit at 15 to 20 mm from the tip of the bit not to drill through the left trunk side panel.
 - Remove any burrs from the edge of the holes using a round file. Apply touch-up paint to the drilled surface and allow the paint to dry thoroughly.

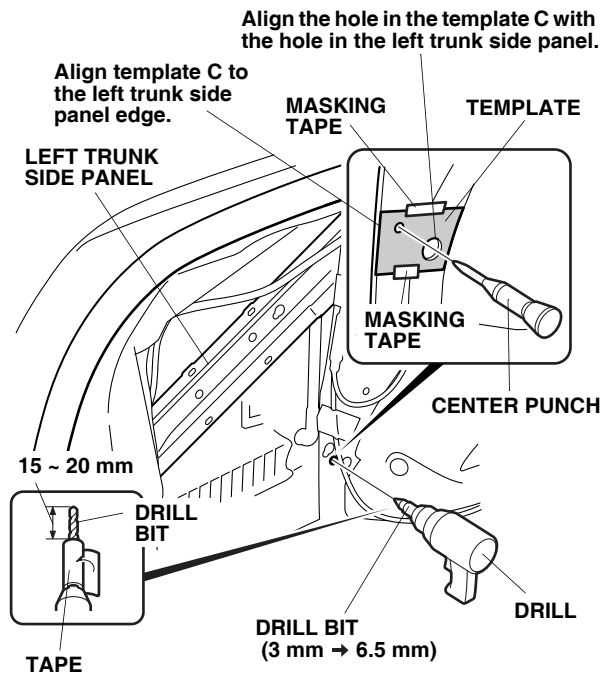

47. Insert the 6 x 16 mm hex bolt, into the 6.5 mm hole made in step 46 of the left trunk side panel, and install two 6 mm plain washers and a 6 mm flange nut. Torque the 6 x 16 mm hex bolt to 9.8 N·m (1 kgf·m, 7.2 lbf·ft)
48. Repeat the steps 44 through 47 on the right side.

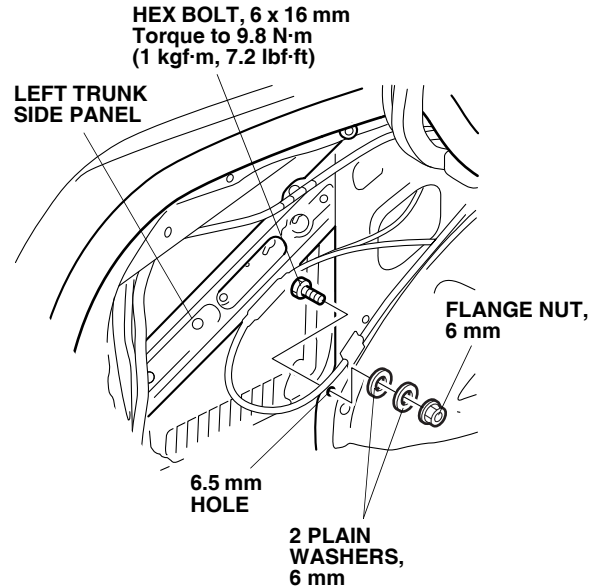

49. Using a pushpin to mark the two scribe marks on the rear of the left trunk side lining.
50. While wearing eye protection, drill at the marked points using a drill with 3 mm bit.
51. Widen a 3 mm hole in step 50 using a drill with 8 mm bit as shown.
52. Widen a 3 mm hole in step 50 using a drill with 11 mm bit as shown.
53. Repeat the step 49 and 52 on the right side.

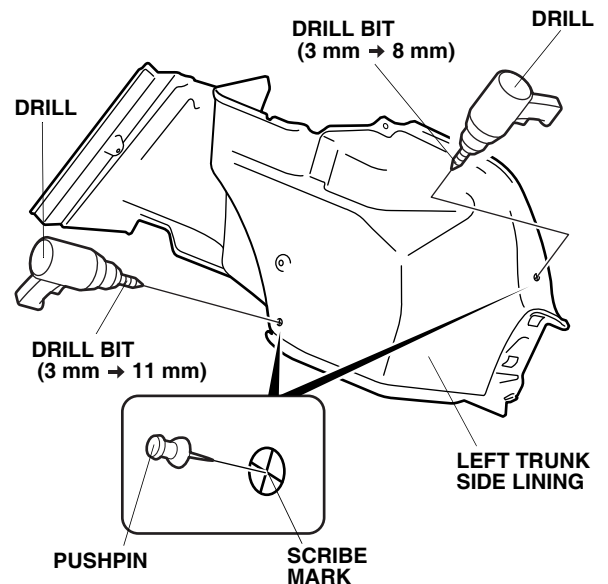

54. Assemble the stud bolt on the anchor B (Small).

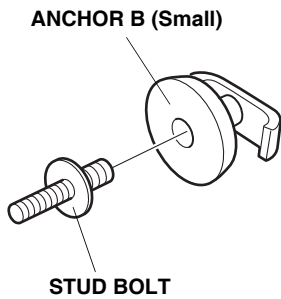

55. Assemble the spacer and the stud bolt on the anchor B (Small).

NOTE: The direction of the spacer.

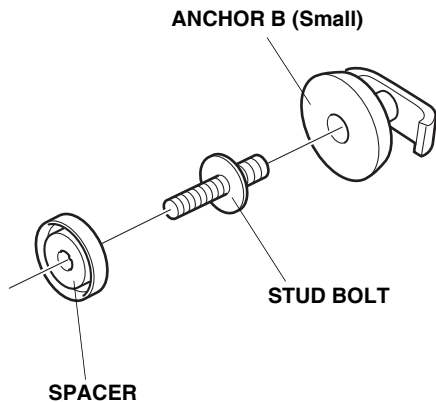

56. Reinstall the left trunk side lining (five clips).

57. Install the anchor B (Small) assembled in step 54 and 55 into the rivet nut installed in step 41.

58. Install the anchor A (Large) to the 6 x 16 mm hex bolt as shown.

59. Repeat the steps 54 through 58 on the right side. Position the anchors in the same ways as shown.

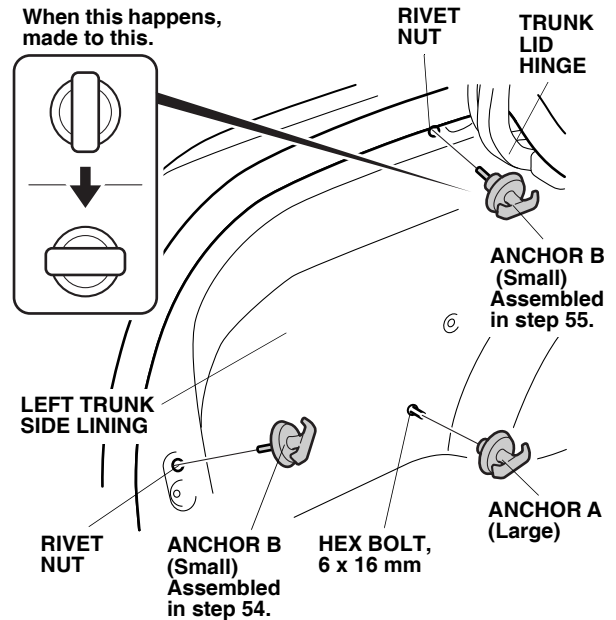

60. Attach the template B to the rear of the rear trim panel using masking tape.

61. Mark the rear of the rear trim panel with a pushpin according to the two template B marks. Remove the template B.

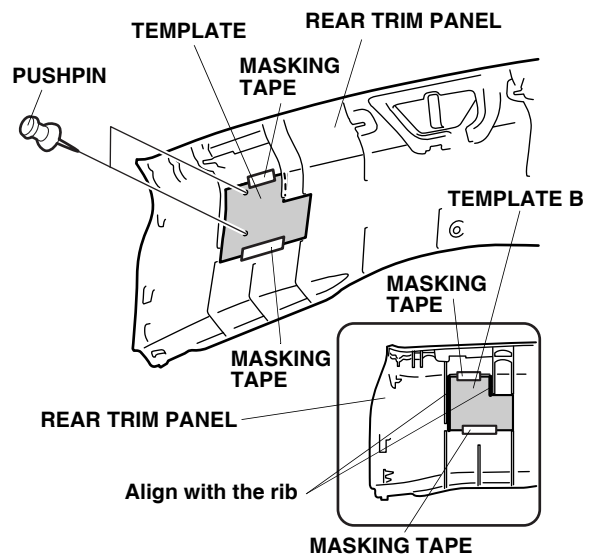

- Reverse the template B. Attach it to the rear of the rear trim panel using masking tape.
- Mark the rear of the rear trim panel with a pushpin according to the two template B marks. Remove the template B.

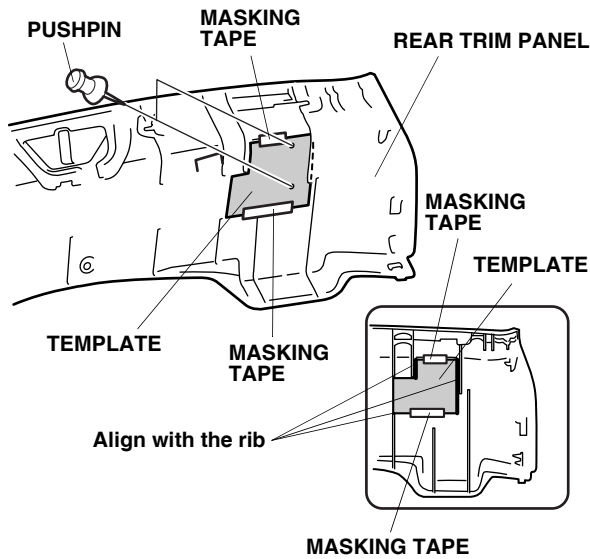

- Drill at the marked points using a drill with 3 mm bit first, finish 6.5 mm bit. Remove any burrs from the edge of the holes using a round file.

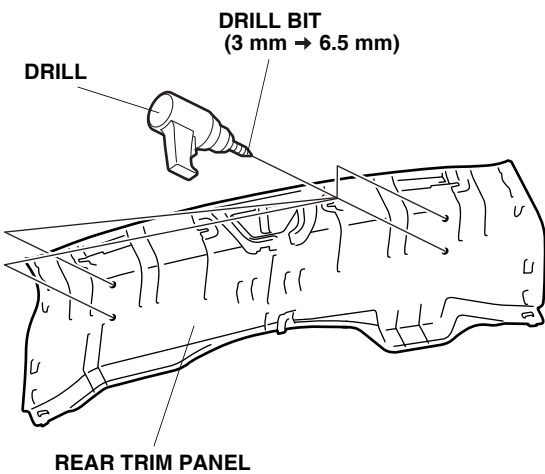

- Install the four anchors B (Small) with four 6 x 16 mm hex bolts, four 6 mm spring washers, and four 6 mm plain washers to the rear trim panel as shown. Torque the 6 x 16 mm hex bolts to 5 N·m (0.5 kgf·m, 3.7 lbf·ft). Position the anchors in the same ways as shown.
- Reinstall the rear trim panel (four clips and three hooks).

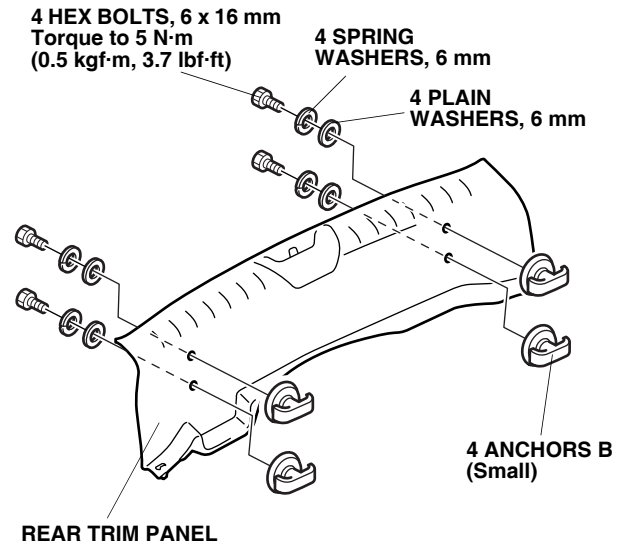

Installing the Cargo Net

Vertical position

67. Hook the loops on the cargo net around the anchors A (Large) and B (Small).

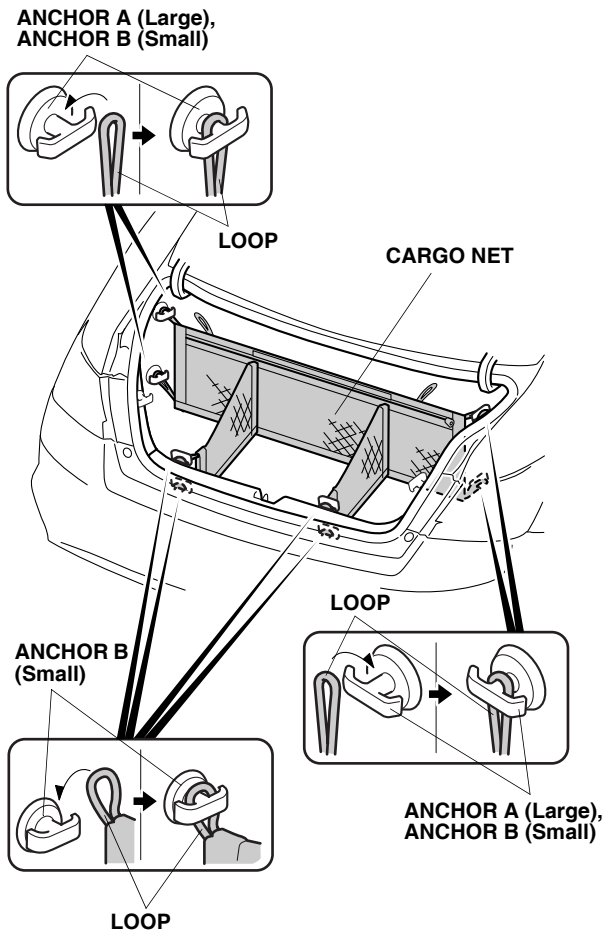

Rear vertical position

68. Attach the magic-fastener as shown on the cargo net.

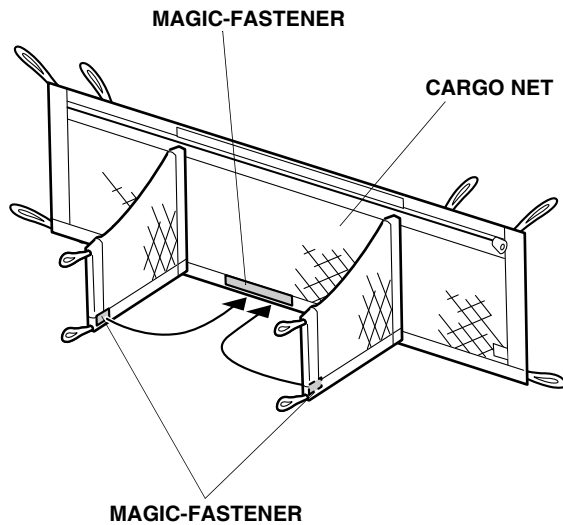

69. Hook the loops on the cargo net around the anchors A (Large). Make sure that the reflector tape is visible after installing.

