



**INSTALLATION
INSTRUCTIONS**

Accessory
CARGO HOOK
P/N 08L96-TA0-100A

Application
2009 ACCORD
2-AND 4-DOOR

Publications No.
All 39940
Issue Date
JULY 2008

PARTS LIST

Cargo hook



Bolt, 6 x 20 mm

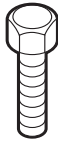

Plain washer, 6 mm



Spring washer, 6 mm



Rivet nut



Accessory User's Information Manual

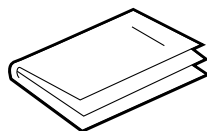

TOOLS REQUIRED

6 mm Rivet nut tool (T/N 07AAE-000A100)

Hex wrench

19 mm Wrench

10 mm Socket

Torque wrench

INSTALLATION

Customer Information: The information in this installation instruction is intended for use only by skilled technicians who have the proper tools, equipment, and training to correctly and safely add equipment to your vehicle. These procedures should not be attempted by "do-it-yourselfers."

NOTE: This instruction shows the cargo hook being installed on the left side of the vehicle. An additional cargo hook (sold separately) can be installed on the right side of the vehicle unless the vehicle is equipped with a navigation unit or a compass.

1. Thread the rivet nut onto the mandrel of the 6 mm rivet nut tool as shown.

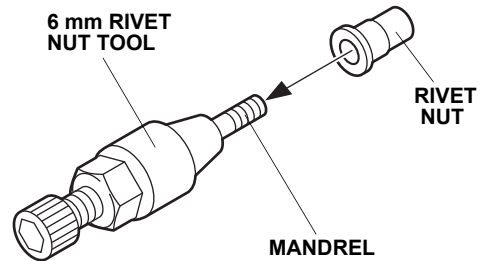

- Open the trunk lid. Insert the rivet nut into the hole in the vehicle panel, and install the hex wrench on the 6 mm rivet nut tool.

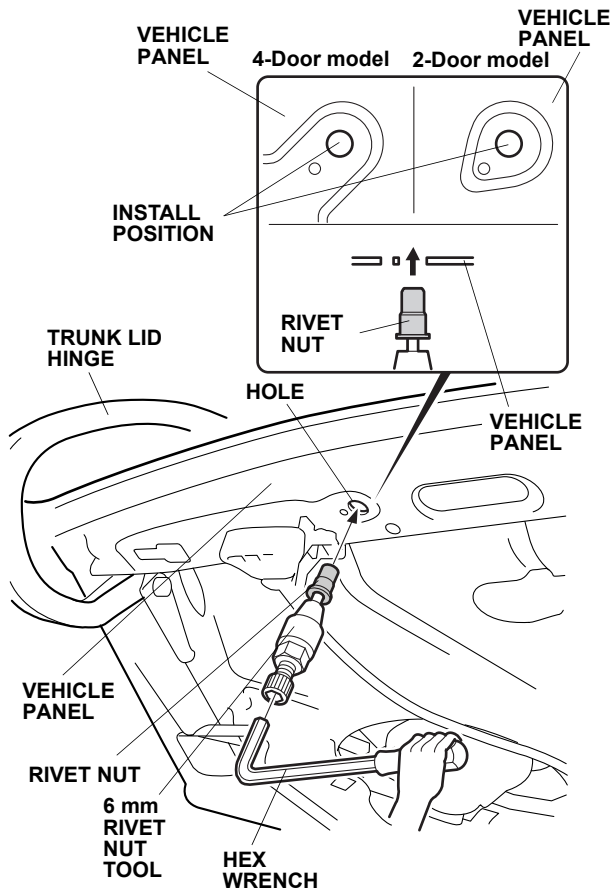

- Holding the 6 mm rivet nut tool with the hex wrench, turn the 19 mm wrench clockwise and install the rivet nut to the vehicle panel.

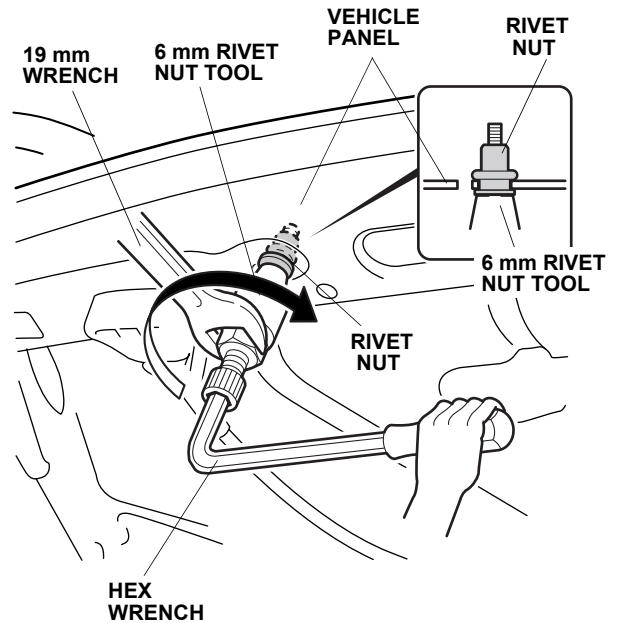

- Remove the 6 mm rivet nut tool from the rivet nut by turning the hex wrench counterclockwise.
- Align the cargo hook pin with the hole in the vehicle panel, and secure the cargo hook to the vehicle panel using the 6 x 20 mm bolt with the 6 mm plain washer and the 6 mm spring washer. Torque the 6 x 20 mm bolt to 4 N·m (3 lb-ft).

