



**INSTALLATION
INSTRUCTIONS**

Accessory

**AMBIENT LIGHT
P/N 08E10-TA0-100**

Application

**2009 ACCORD
2-AND 4-DOOR**

Publications No.

All 40056

Issue Date

JULY 2008

PARTS LIST

Ambient Light Kit

2 Ambient lights

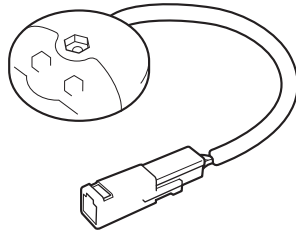

Ambient light harness

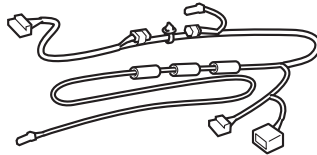

2 Brackets

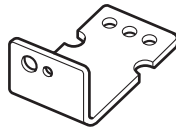

Ambient light switch

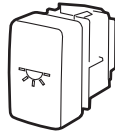

Switch trim

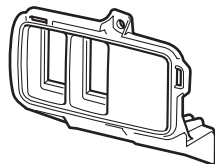

Template

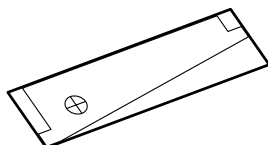

Fuse label

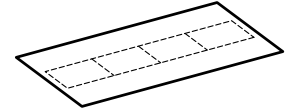

Washer screw, 6 x 16 mm

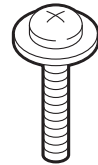

Self-tapping screw, 4 x 16 mm



2 Pan-head screws, 4 x 20 mm

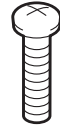

Wire tie (Thin)

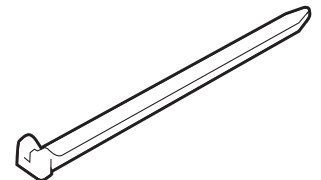

11 Wire ties

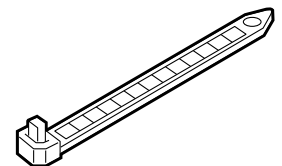

Wire tie with clip

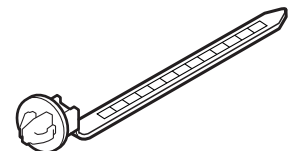

2 Flange nuts, 4 mm



Flange nut, 6 mm



TOOLS AND SUPPLIES REQUIRED

#2 Phillips screwdriver

Flat-tip screwdriver

Tape

Wire

Scissors

Pushpin

Diagonal cutters

Ratchet

8 mm and 10 mm Socket

10 mm Combination wrench

Drill

3 mm, 5 mm, 7 mm, and 10 mm Drill bits

Illustration of the Ambient Light Installed on the Vehicle

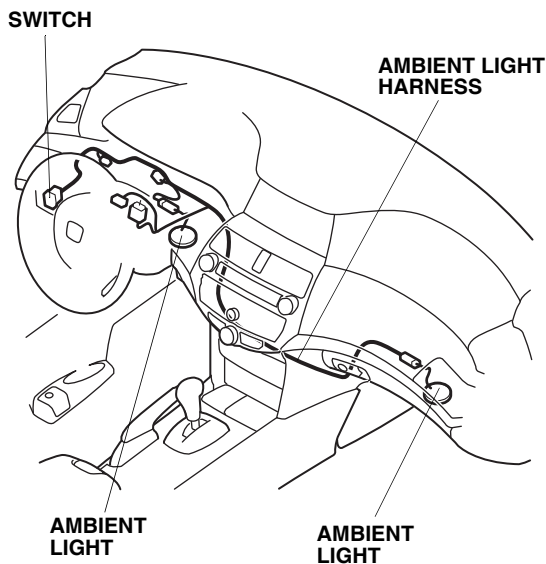

INSTALLATION

Customer Information: The information in this installation instruction is intended for use only by skilled technicians who have the proper tools, equipment, and training to correctly and safely add equipment to your vehicle. These procedures should not be attempted by “do-it-yourselfers.”

1. Make sure you have the anti-theft codes for the audio and navigation system (if equipped), then write down the customer’s radio station presets.
2. Disconnect the negative cable from the battery.
3. Remove the driver’s dashboard lower cover (eight clips, two hooks, and disconnect the vehicle connector).

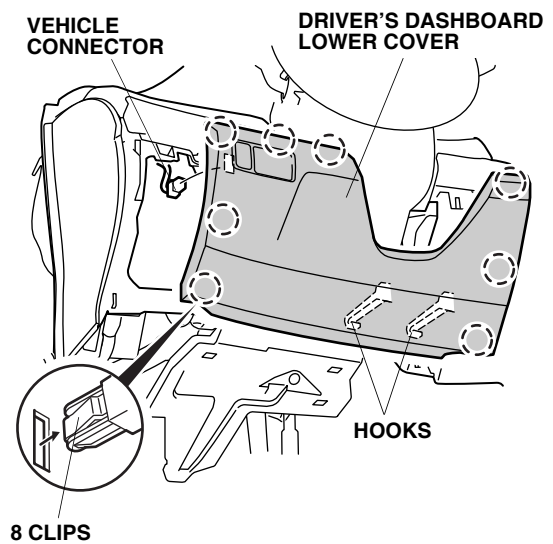

4. V6 Model only: Remove the driver’s dashboard under cover (three clips and one pin).

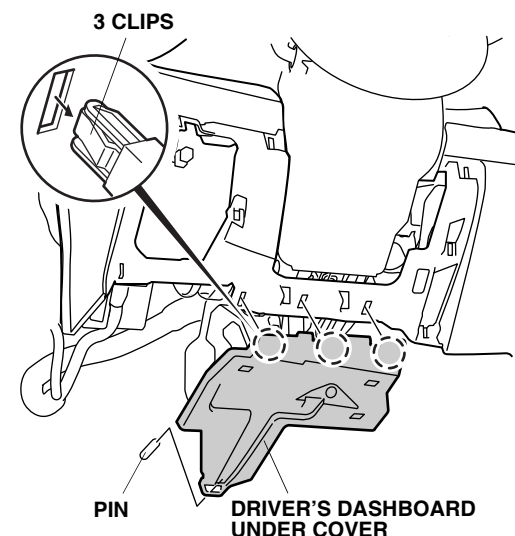

5. V6 Model only: Remove the passenger's dashboard under cover (three clips and two pins).

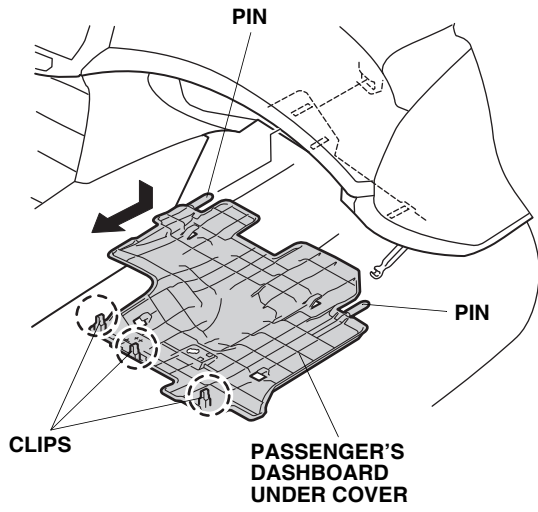

6. Release the glove box (damper and two stops).

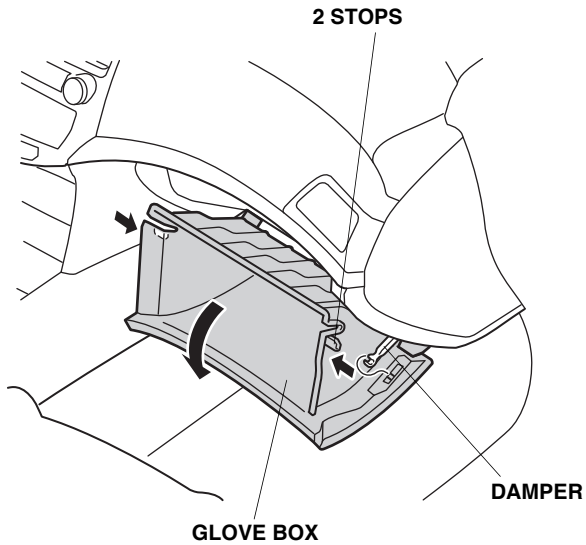

7. Remove the glove box (two screws).

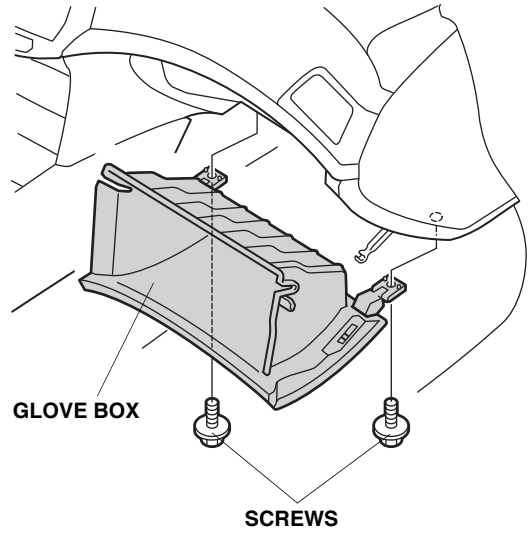

8. Lower the tilt lever on the steering column, and pull the steering wheel out.

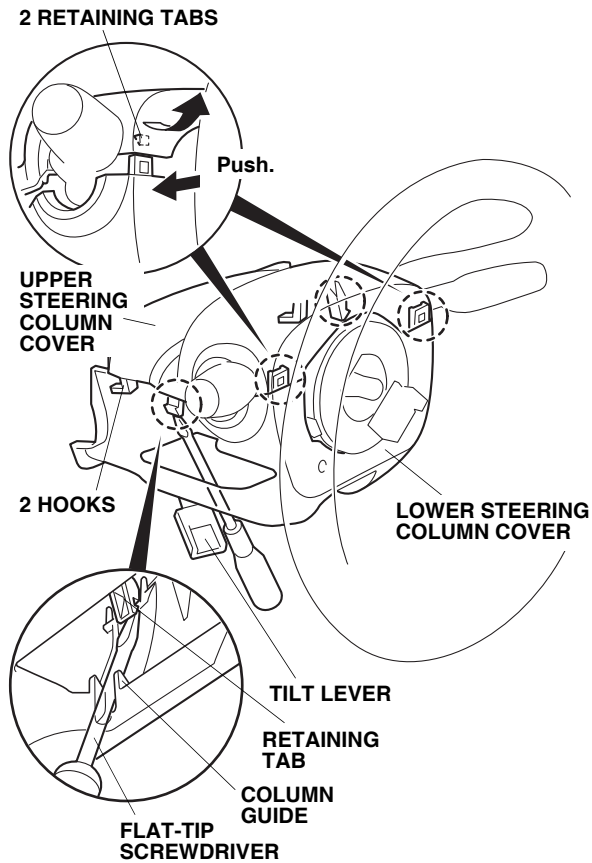

9. Remove the upper steering column cover:
- Insert a flat-tip screwdriver along the column guide inside the lower cover, and gently pry out the retaining tab of the upper column cover.
 - Push in the lower cover at the areas shown to release the two retaining tabs, and pull up on the upper cover to release the two hooks.

10. Remove the lower steering column cover (two self-tapping screws and one screw).

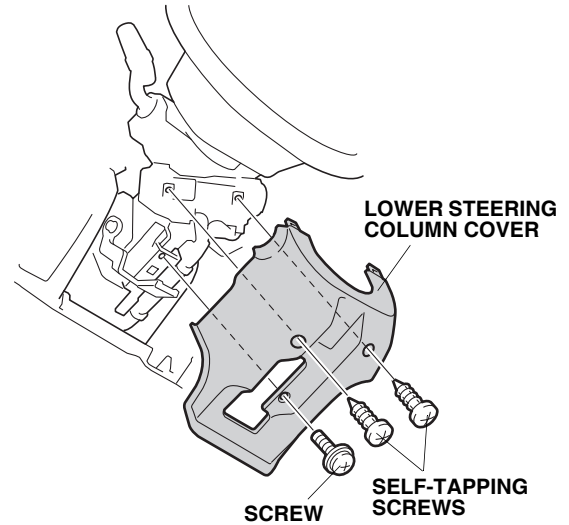

Installing the Ambient Light Switch

11. Remove the three self-tapping screws from the rear of the driver's dashboard lower cover, and remove the pocket.

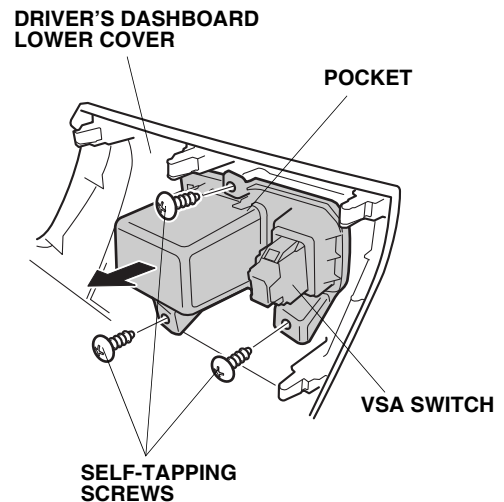

12. Release the two retaining tabs and remove the VSA switch from the pocket. Set the pocket aside, it will not be reused.

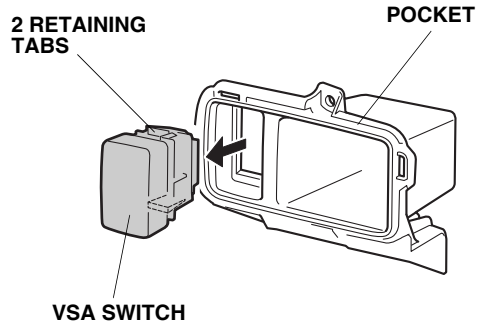

13. Install the VSA switch (removed in step 12) and the ambient light switch into the switch trim provided.

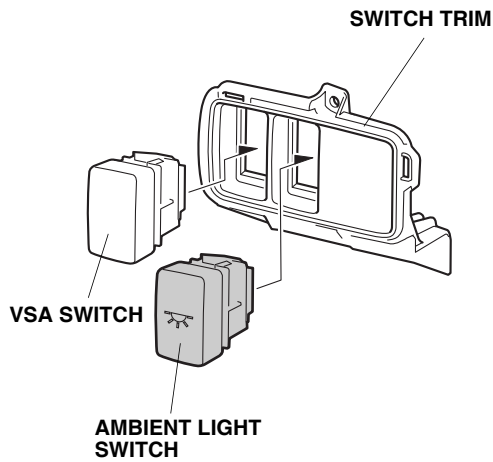

14. Install the new switch trim to the driver's dashboard lower cover with three self-tapping screws.

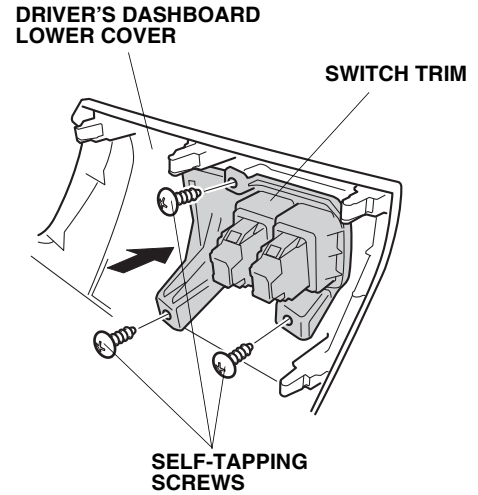

Routing the Ambient Light Harness

15. Attach the 2 A fuse label to the fuse case on the ambient light harness.

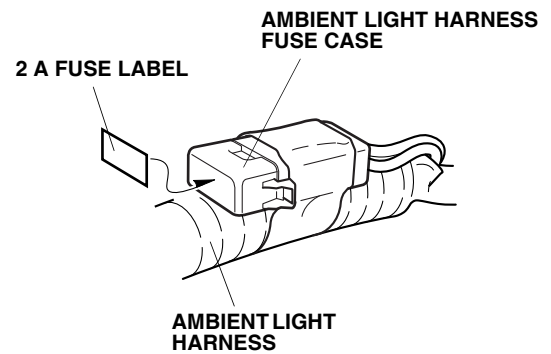

16. Route the ambient light harness 5-pin connector as shown, and secure the ambient light harness clip to the vehicle frame.

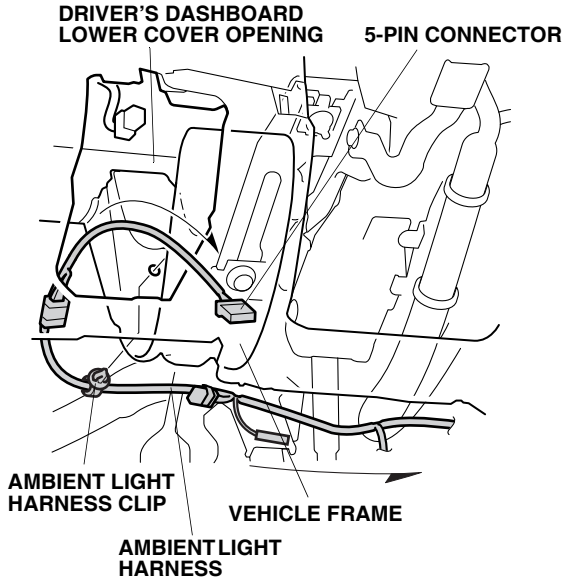

17. Secure the ambient light harness to the vehicle harness with two wire ties.

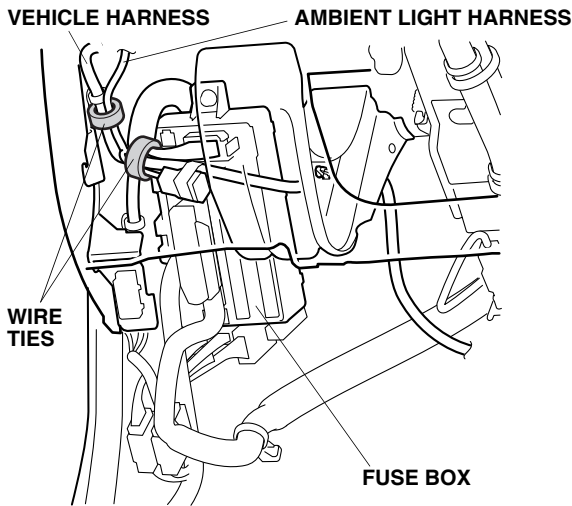

18. Route the ambient light harness 20-pin connectors along the vehicle harness.

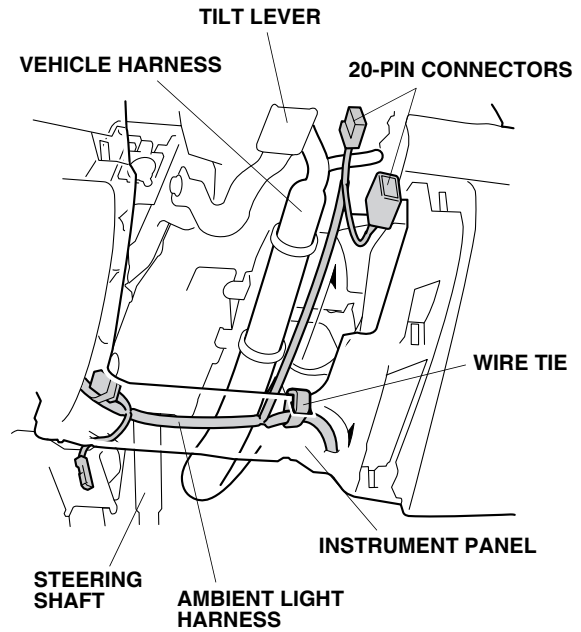

19. Secure the ambient light harness to the instrument panel with one wire tie.
 20. Disconnect the vehicle harness 20-pin connector from the body switch, and plug in the ambient light harness 20-pin connector. Plug the vehicle harness 20-pin connector into the ambient light harness 20-pin connector.

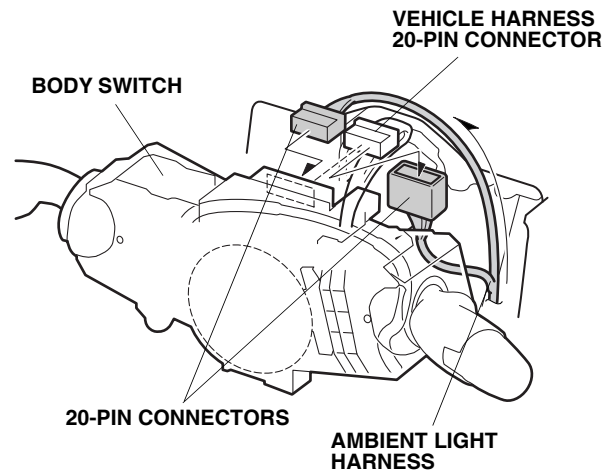

21. Secure the ambient light harness connector and the vehicle harness 20-pin connector to the vehicle harness with one thin wire tie.

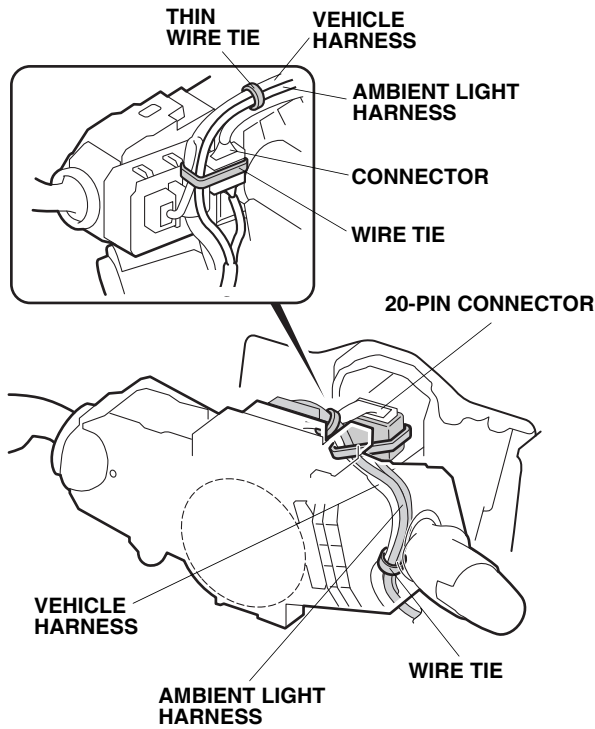

22. Secure the ambient light harness to the vehicle harness with two wire ties.
23. Along the vehicle harness, secure the ambient light harness to the vehicle harness with two wire ties.

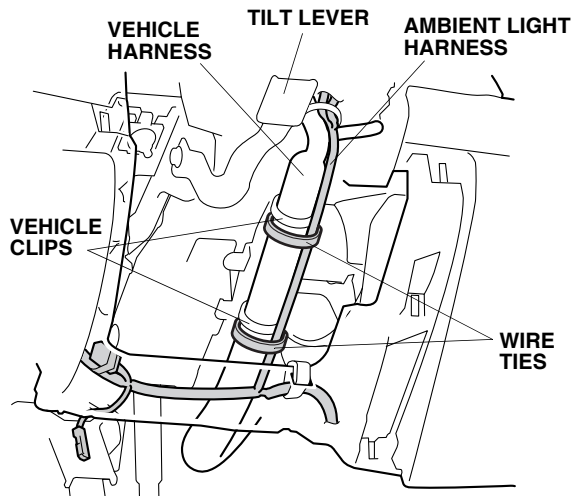

24. Using a piece of wire taped to the ambient light harness, route the harness from the driver's footwell to the front passenger's footwell.

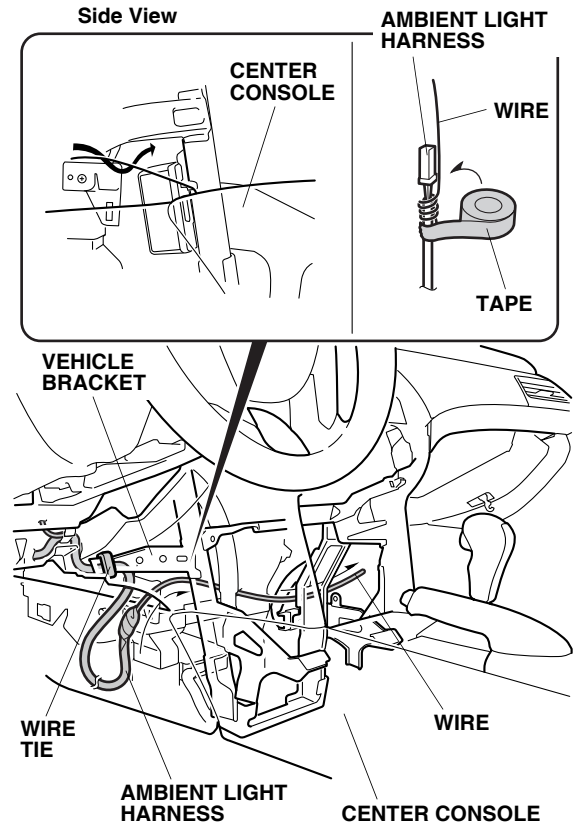

25. Secure the ambient light harness to the vehicle bracket with one wire tie.

26. Untape the wire from the harness. Route the ambient light harness as shown, and secure the ambient light harness to the vehicle harness with one wire tie in the area shown.

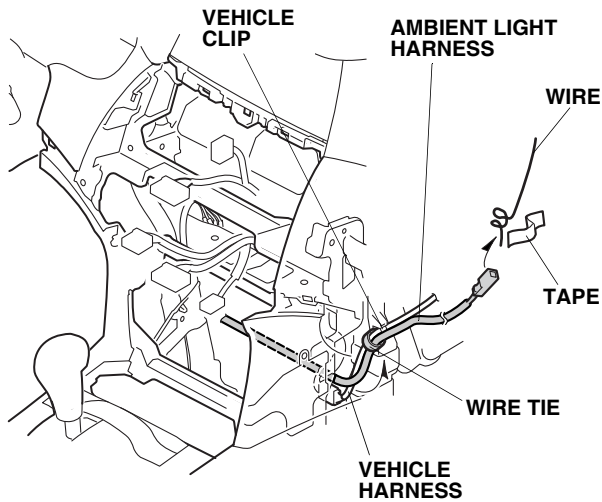

27. Route the ambient light harness to the glove box opening.

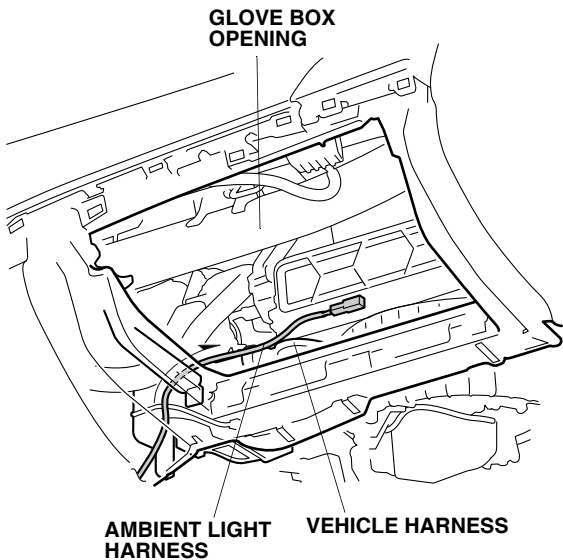

Installing the Ambient Lights

For L4 model, go to step 28. For V6 model, go to step 30.

28. Install the ambient light on the driver's side:

- Secure the ambient light to the bracket with a 4 mm flange nut and a 4 x 20 mm pan-head screw.

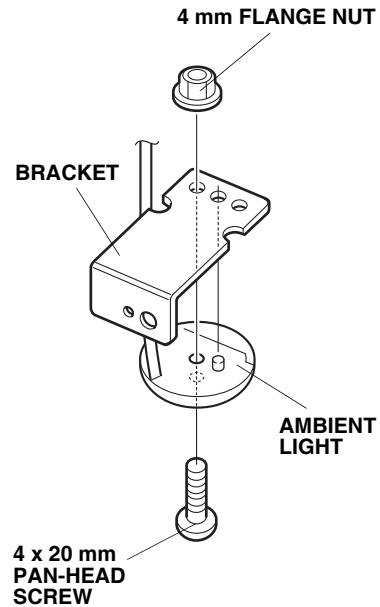

- Install the ambient light to the instrument panel with one 4 x 16 mm self-tapping screw.

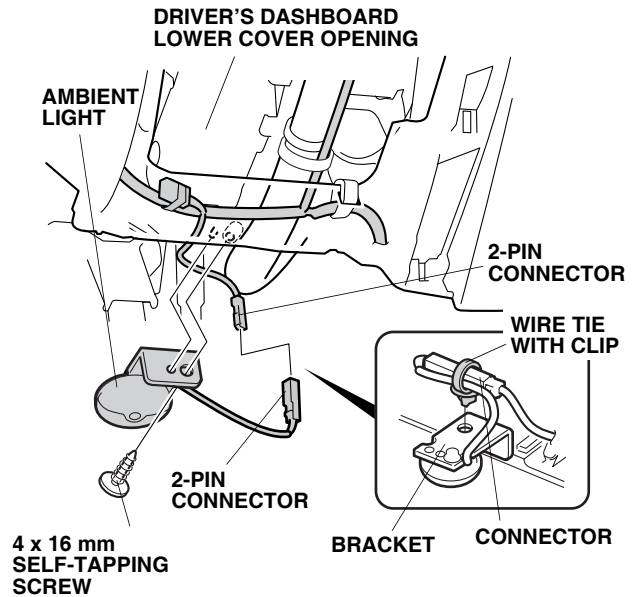

- Plug the ambient light 2-pin connector into the ambient light harness.
- Secure the ambient light harness connector to the bracket with one wire tie with clip.

29. Install the ambient light on the passenger's side of the vehicle:
- Using scissors, cut out the template.

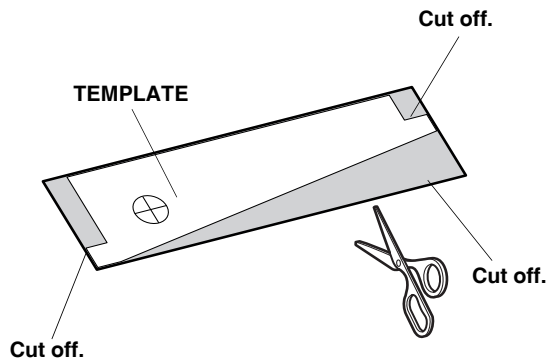

- Under the glove box opening, align the template with the instrument panel as shown.

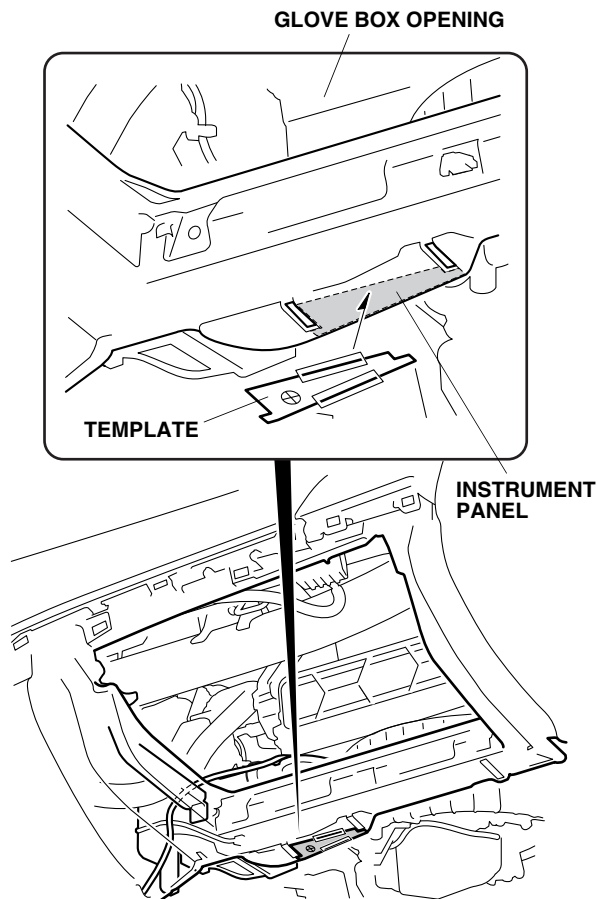

- Using a pushpin, pierce the instrument panel at the mark on the template. Remove the template.

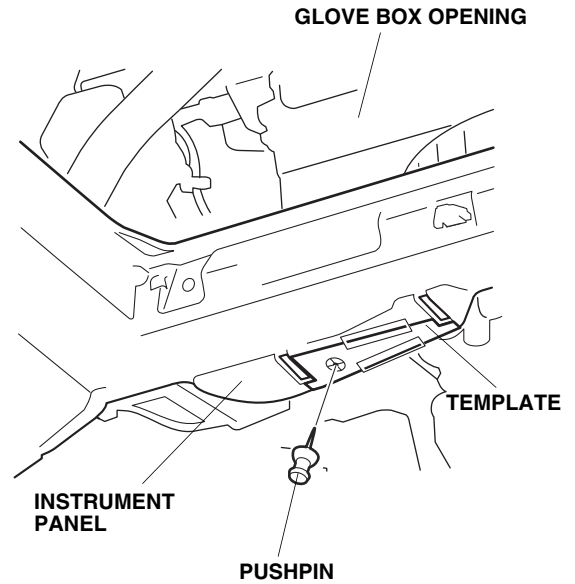

- While wearing eye protection, drill a 7 mm hole through the instrument panel at the marked position. First drill with a 3 mm drill bit, and finish with a 7 mm drill bit.

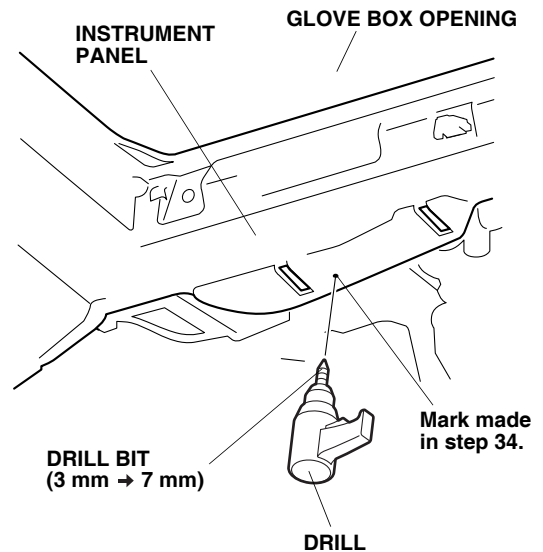

- Secure the ambient light to the bracket with one 4 mm flange nut and one 4 x 20 mm pan-head screw.

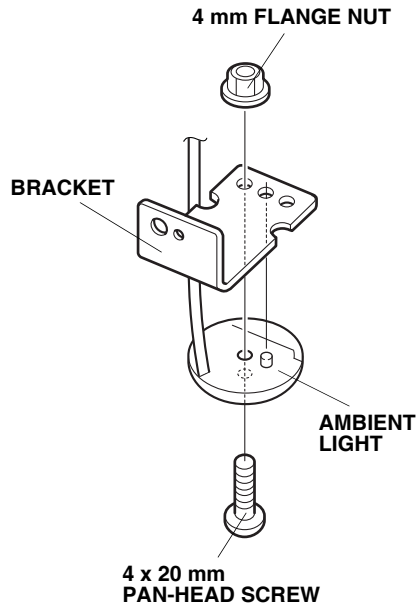

- Secure the ambient light to the instrument panel with one 6 mm flange nut, and one 6 x 16 mm washer screw.

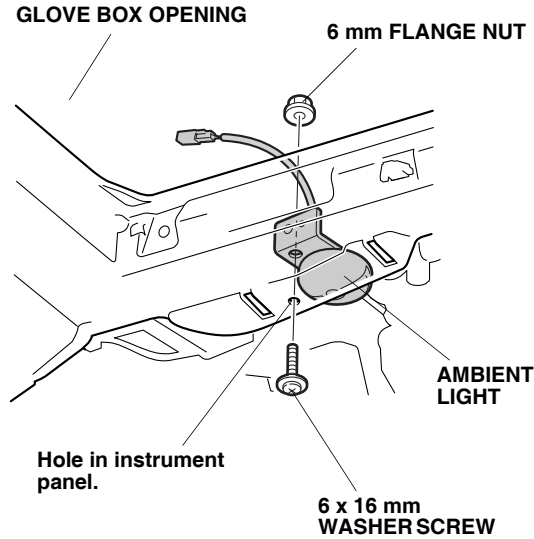

- Plug the ambient light 2-pin connector into the ambient light harness 2-pin connector.

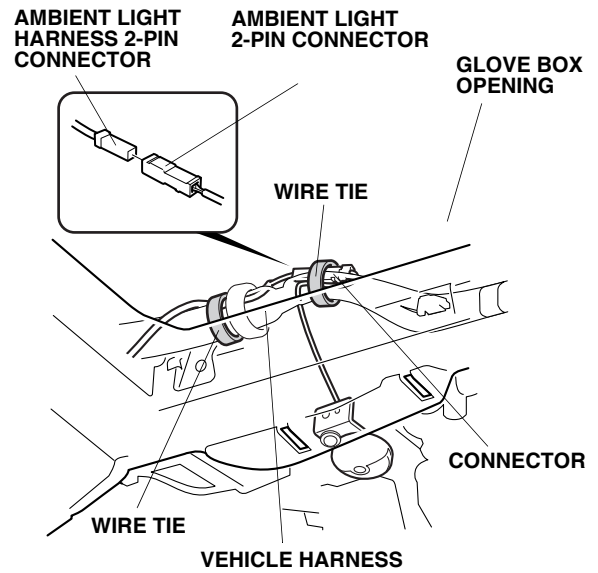

- Secure the ambient light harness to the vehicle harness with one wire tie in the location shown, and secure the 2-pin connector to the vehicle harness with one wire tie.
- Go to step 32.

V6 Model

30. Install the ambient light on the driver's side:

- While wearing eye protection, drill a 5 mm hole and a 10 mm hole in the driver's dashboard lower under cover in the areas shown. First drill the right hole with 3 mm drill bit, and finish with a 5 mm drill bit. Then drill the left hole with 3 mm drill bit, and finish with a 10 mm drill bit.

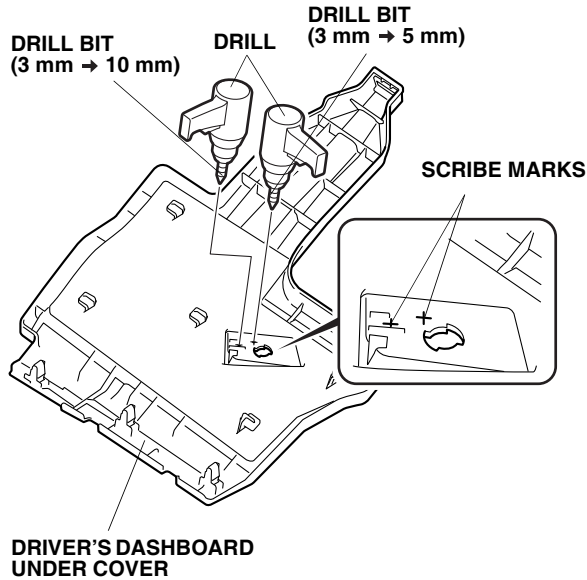

- Using a utility knife, cut out the driver's dashboard under cover area shown.

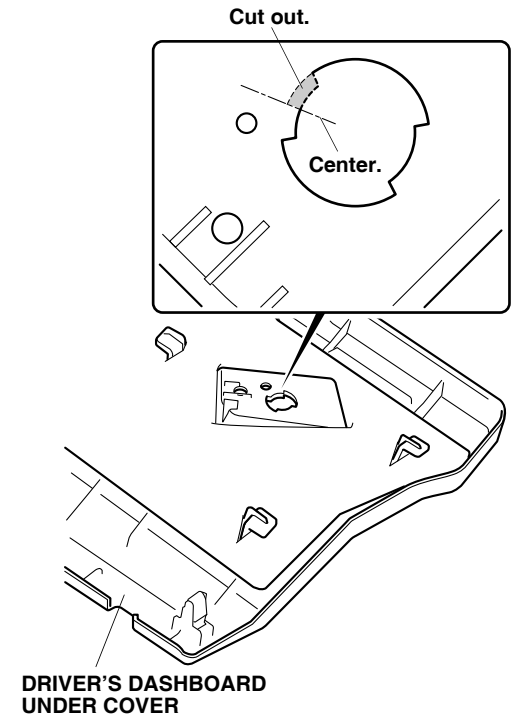

- Route the ambient light 2-pin connector through the 10 mm hole, and attach the ambient light to the driver's dashboard under cover with one 4 x 20 mm pan-head screw and one 4 mm flange nut through the 5 mm hole.

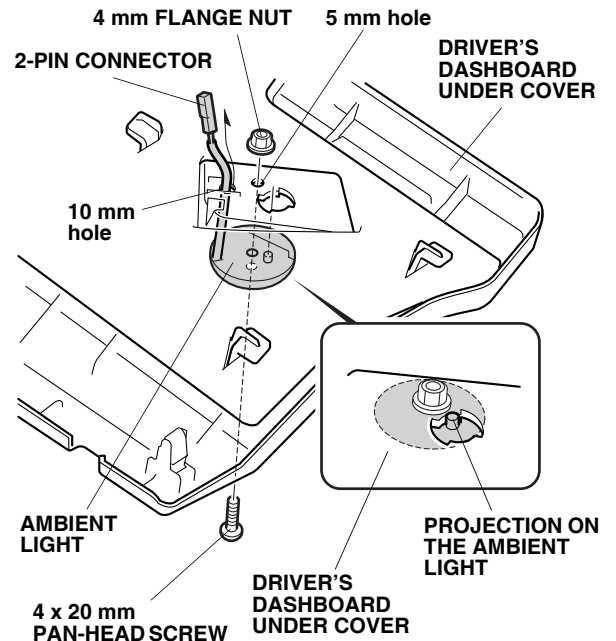

- Install the bracket to the instrument panel using one 4 x 16 mm self-tapping screw.

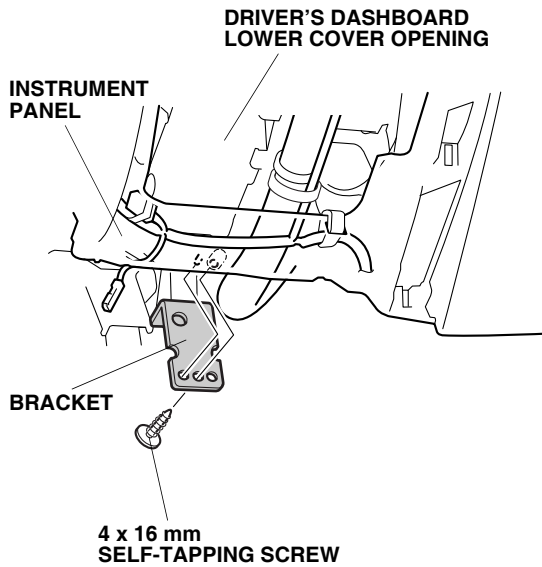

- Plug the ambient light 2-pin connector into the ambient light harness 2-pin connector, and secure the ambient light harness to the bracket using one wire tie with clip. Then, reinstall the driver's dashboard under cover.

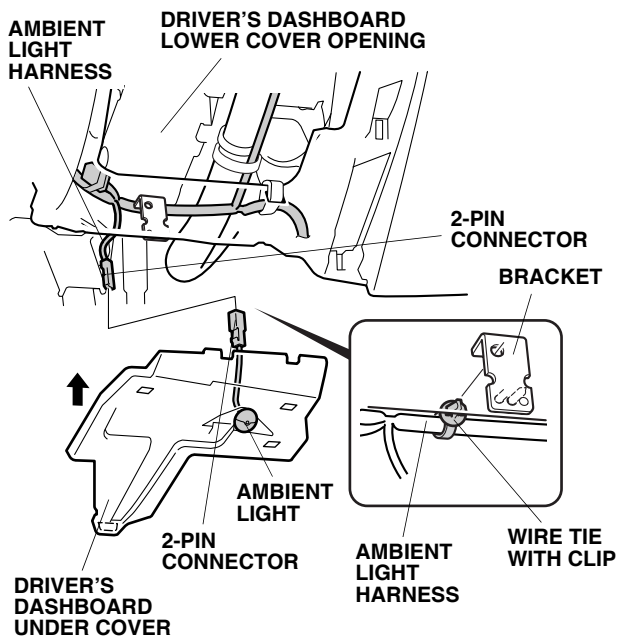

31. Install the ambient light on the passenger's side:
- While wearing eye protection, drill two 5 mm holes and one 10 mm hole in the passenger's dashboard under cover in the areas shown. First drill all of the holes with 3 mm drill bit, and finish with a 5 mm drill bit. Enlarge the left hole to 10 mm using a 10 mm drill bit.

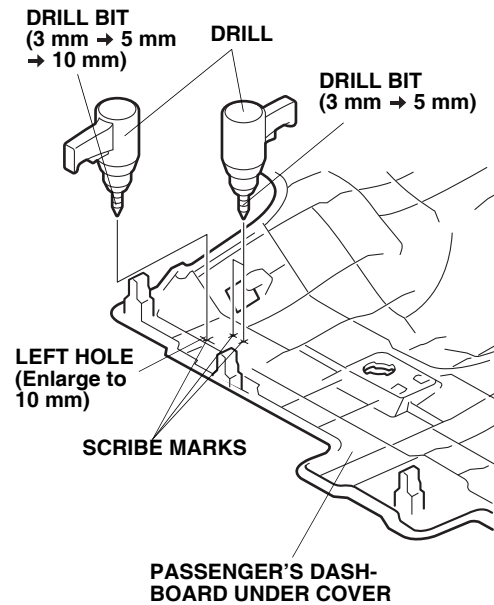

- Route the ambient light 2-pin connector through the 10 mm hole, and attach the ambient light to the passenger's dashboard under cover with one 4 x 20 mm pan-head screw and one 4 mm flange nut through the 5 mm hole.

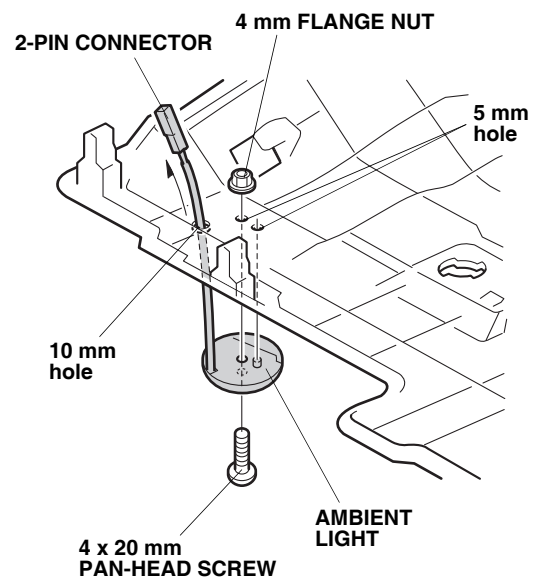

- Plug the ambient light 2-pin connector into the ambient light harness 2-pin connector, and secure the 2-pin connector to the vehicle harness with one wire tie. Then, reinstall the passenger's dashboard under cover.

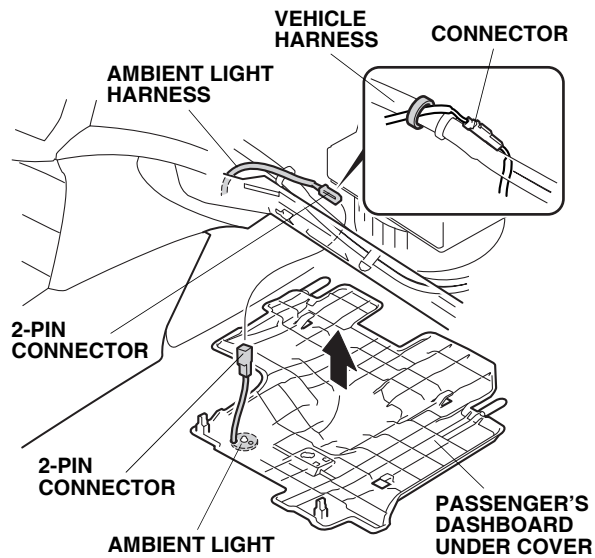

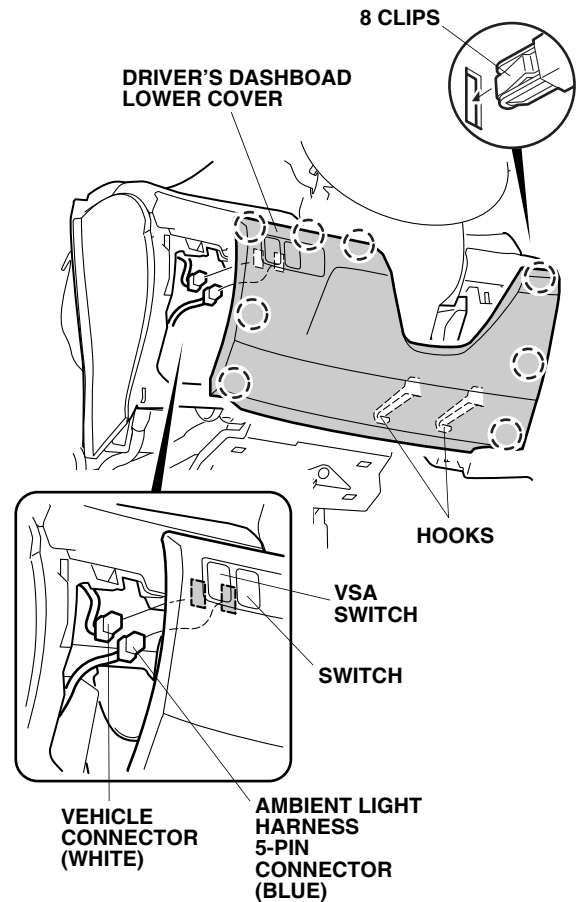

32. Plug the ambient light harness 5-pin blue connector into the ambient light switch, plug the VSA connector 5-pin connector into the VSA switch, and reinstall the driver's dashboard lower cover.



33. Check that all wire harnesses are routed properly and all connectors are plugged in.
34. Reinstall all removed parts.
35. Reconnect the negative cable to the battery, and verify that the ambient lights illuminate.
36. Enter the radio and navigation (if equipped) anti-theft codes.
37. Reset the clock on models without navigation.

HOW TO OPERATE

- Turn the headlight switch to the “ ” or “ ” position (headlights on low beam).
- Press the ambient light switch.

