

HONDA

INSTALLATION INSTRUCTIONS

Accessory
SECURITY SYSTEM

Application
2001 CR-V

Publications No.
All 21698
Issue Date
OCT 2000

PARTS LIST

**Security System Kit (sold separately):
P/N 08E51-SV4-102F**

2 Remote controls

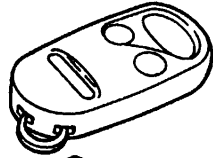

Control unit

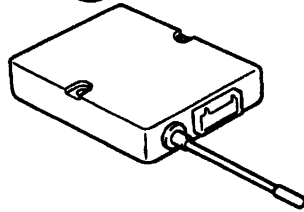

LED

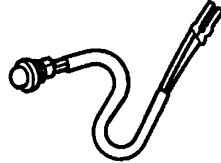

Push nut



2-Pin connector

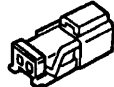

Disarm switch

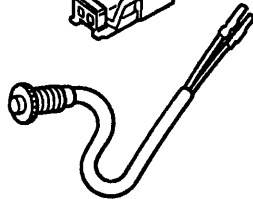

Fuse label



3-Pin connector

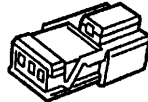

Nut, 12 mm



Washer



Owner's Manual



2 Washer-screws, 4 x 30 mm



**Attachment Kit (sold separately):
P/N 08E55-S10-101**

Sub-harness



Mini fuse (3A)



2 Cushion tapes



Control unit bracket

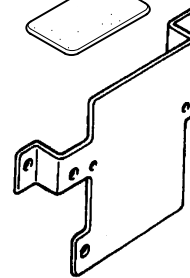

Fuse label

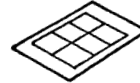

5 Flange bolts



3 Flange nuts



2 Wire ties (large)



Wire tie with clip



Wire tie (small)



2 4-Pin relays

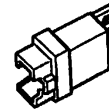

2 6-Pin relays

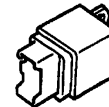

2 Relay brackets



Flange bolt, 6 x 20 mm



Collar



TOOLS AND SUPPLIES REQUIRED

Small flat-tip screwdriver
#2 Phillips screwdriver
Eye protection (face shield, safety goggles, etc.)
Drill
5.5 mm, 10 mm, and 12 mm Drill bits
Tape measure
File
Felt-tip pen
Pliers
17 mm Open-end wrench
10 mm Socket wrench

Illustration of the Security System Options Installed on the Vehicle

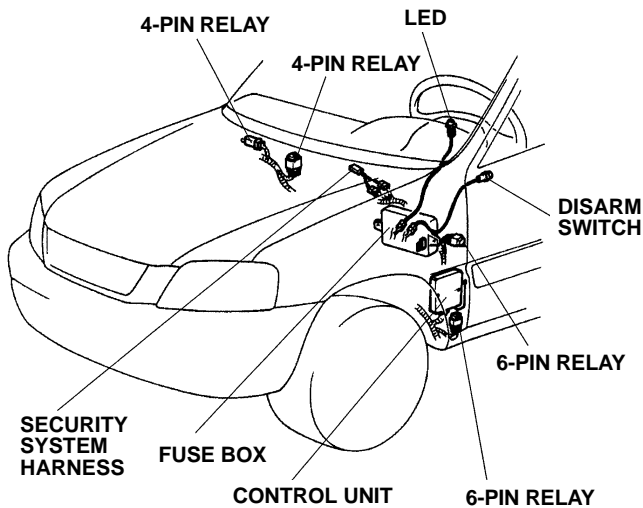

Adjusting the Control Unit

- Use a small flat-tip screwdriver to change the mode switch and the horn/siren switch and to adjust sensitivity.

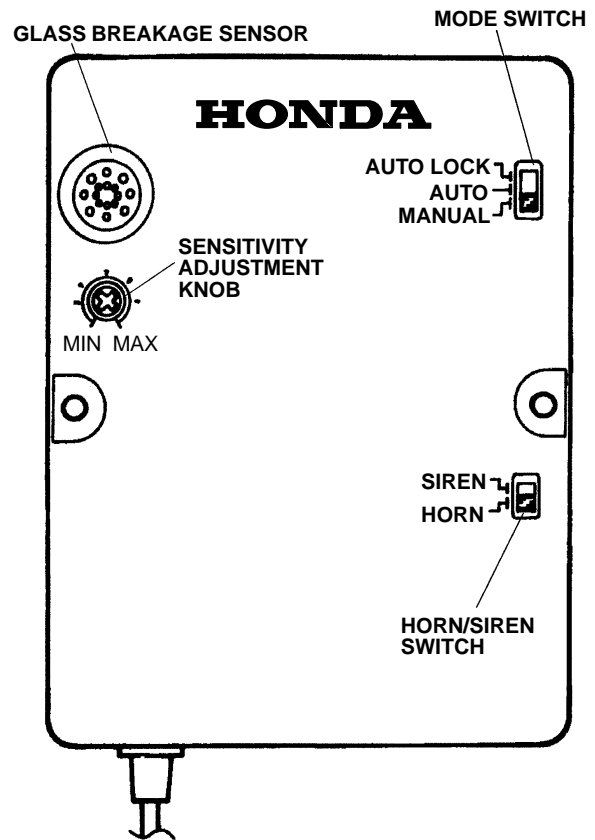

Mode Switch:

- Set the mode switch according to the customer's choice.
- Refer to the Owner's Manual for the explanation of each mode.

Horn/Siren Switch:

- Set the switch to "HORN" in normal use. If an optional siren is installed, set the switch to "SIREN."

Glass Breakage Sensor:

- Do not attach anything like scotch tape over these holes; this is the microphone pick-up.

Sensitivity:

- Adjust the sensitivity only if the customer requests it; the sensitivity adjustment of the glass break sensor is factory set.
- Be careful when you adjust the sensitivity; if you raise the sensitivity too much, the security system can give you a false alarm, and if the sensitivity is too low, the security system may not work even if glass is broken.

INSTALLATION

Customer Information: The information in this installation instruction is intended for use only by skilled technicians who have the proper tools, equipment, and training to correctly and safely add equipment to your vehicle. These procedures should not be attempted by "do-it-yourselfers."

1. If equipped, make sure you have the anti-theft code for the radio, then write down the frequencies for the preset buttons.
2. Disconnect the negative cable from the battery.
3. Remove the driver's dashboard lower cover (two self-tapping screws, four retaining clips, and one connector).

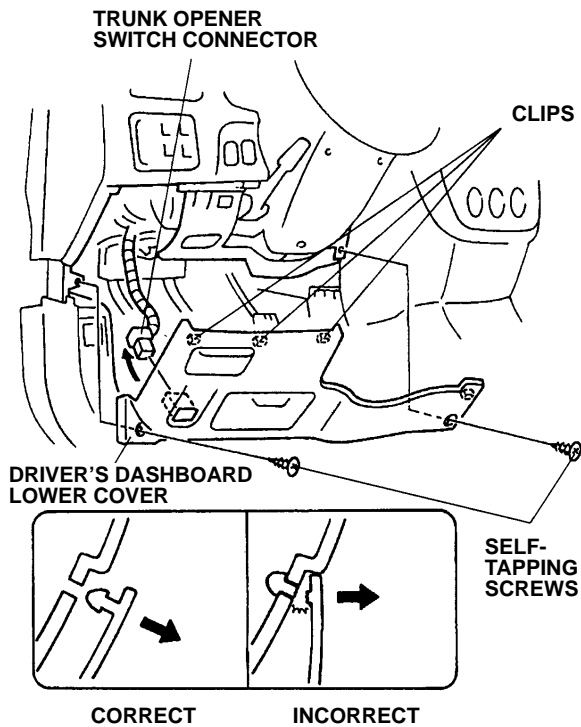

4. Remove the knee bolster (three bolts).

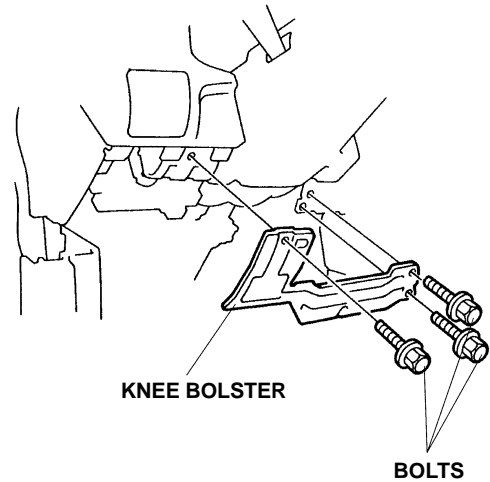

5. Remove the footrest (two bolts).

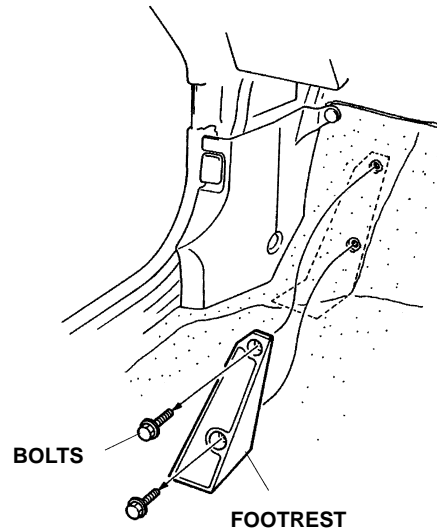

6. Remove the left kick panel (two clips, and slide back).

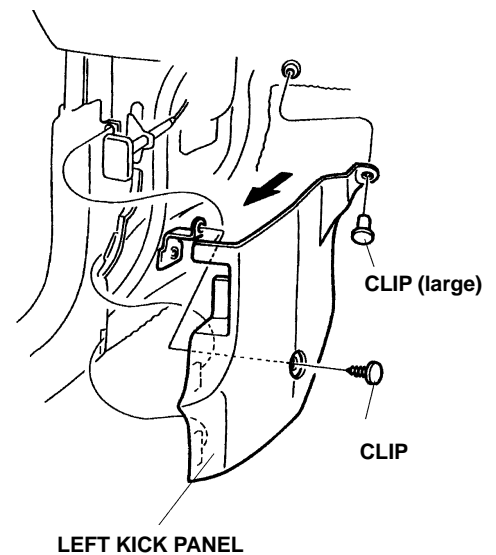

- Open the glove box. Squeeze the retaining tabs, and remove the stoppers. Pull the glove box down.

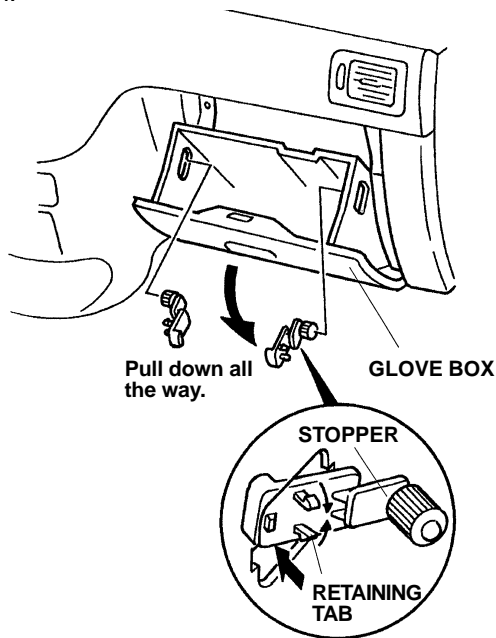

- Remove the upper and lower steering column covers (three screws, six clips, one tab). Insert a flat-tip screwdriver between the steering wheel and steering column cover at the locations shown.

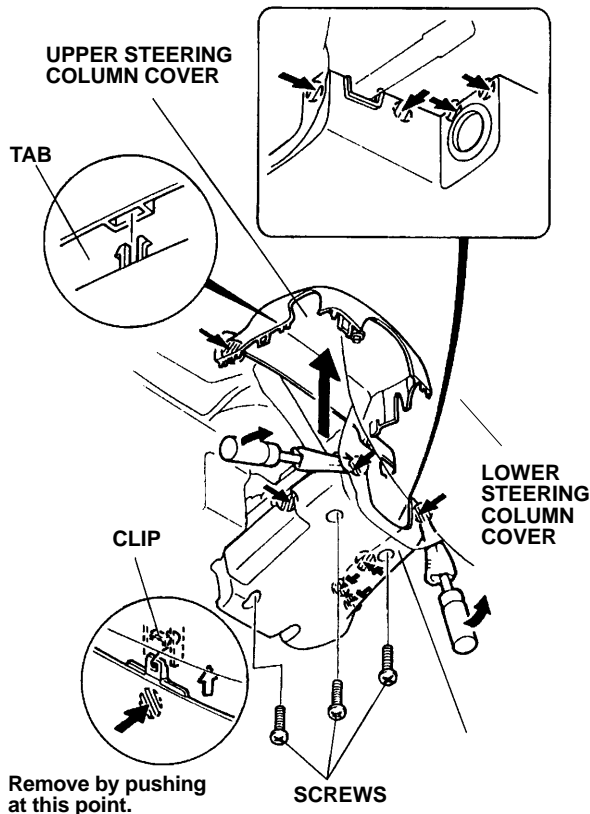

- Measure and mark the upper steering column cover, and lightly center-punch the mark.

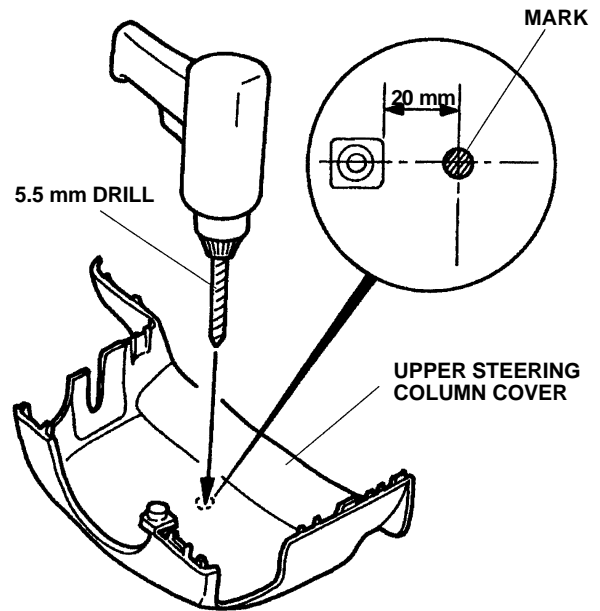

- While wearing eye protection, drill a 5.5 mm hole through the center-punched mark. Remove all burrs.
- Route the terminal ends of the LED through the hole you just drilled, and secure the LED with the push nut. Install the push nut securely.

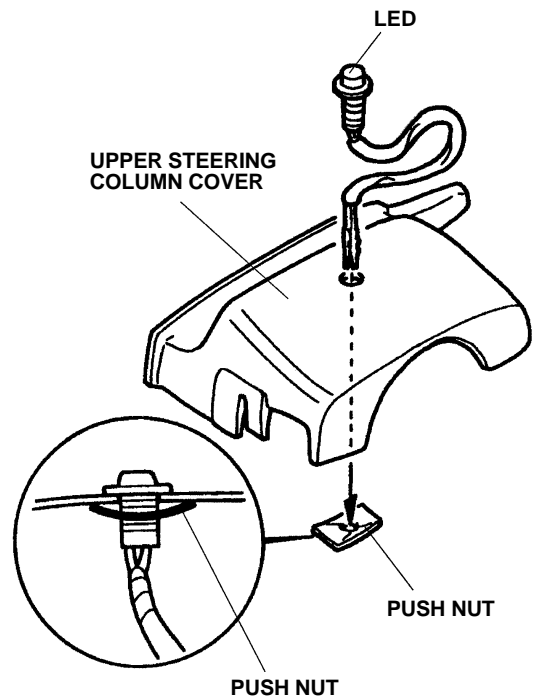

12. Carefully push the LED terminals into the 2-pin connector from the kit.

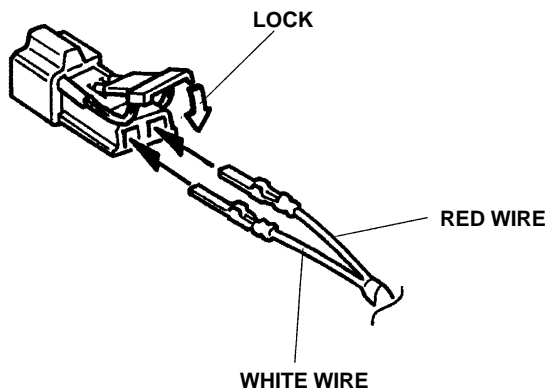

13. Measure and mark the lower cover as shown, and lightly center-punch the mark.

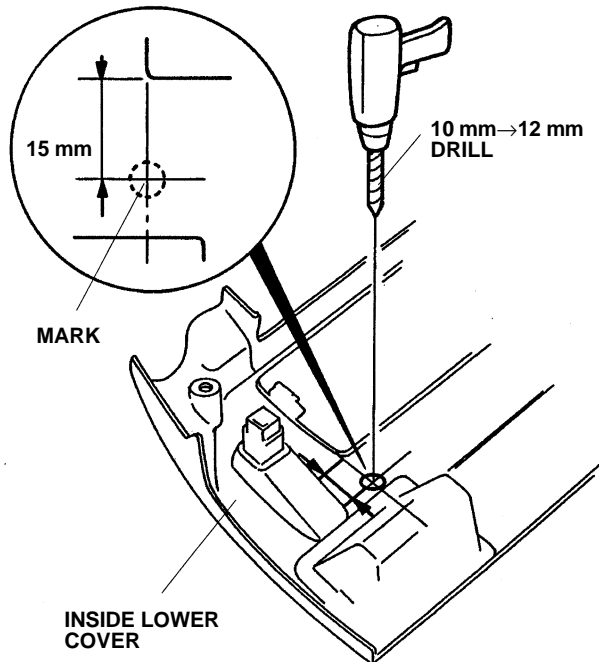

14. While wearing eye protection, drill a 12 mm hole through the center-punched mark:

- First drill a pilot hole with a 10 mm bit, then finish with a 12 mm bit.
- Remove all burrs.

15. Route the terminal ends of the disarm switch through the hole you just drilled, and secure the assembly with the washer and 12 mm nut.

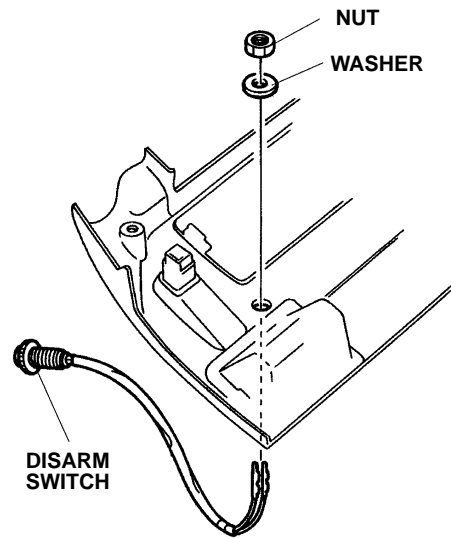

16. Locate the 3-pin connector included in the kit. Firmly push the disarm switch terminals into the 3-pin connector, and lower the lock. Get the cushion tape from the kit, and cut it in half. Attach one half of the cushion tape to the 3-pin connector.

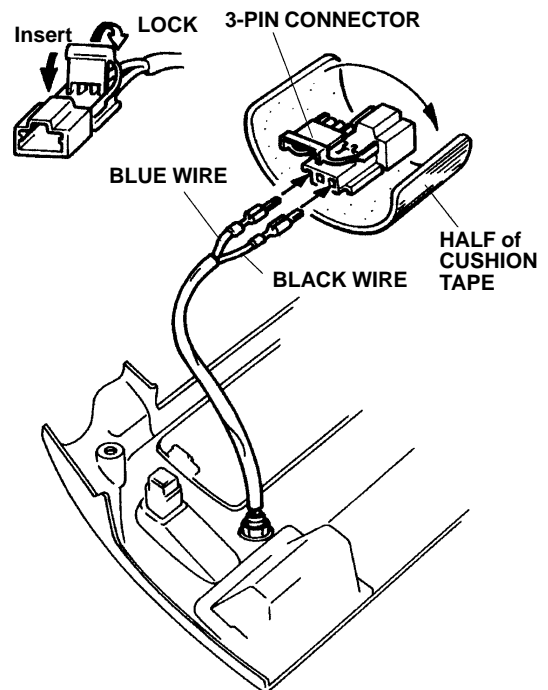

17. Attach the other half of the cushion tape to the unit bracket in the area shown, then attach the 6-pin relay to the unit bracket with the appropriate flange bolt and flange nut provided.

A/T Model: Use the 6 x 12 mm flange bolt.

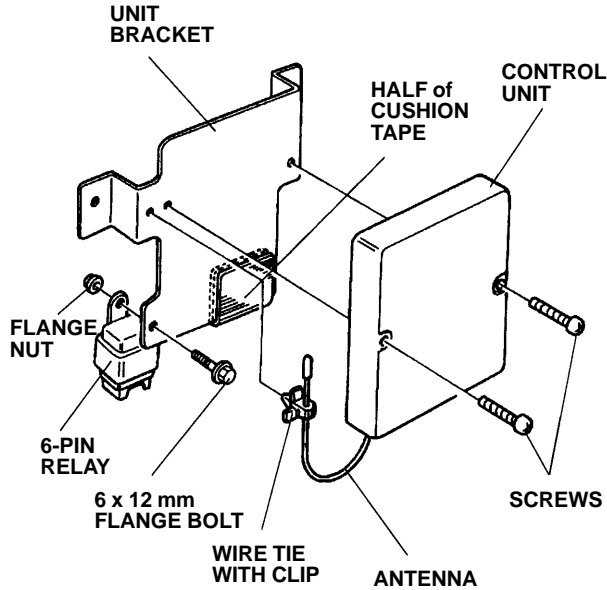

M/T Model: Use the 6 x 20 mm flange bolt and the collar. Angle the relay as shown.

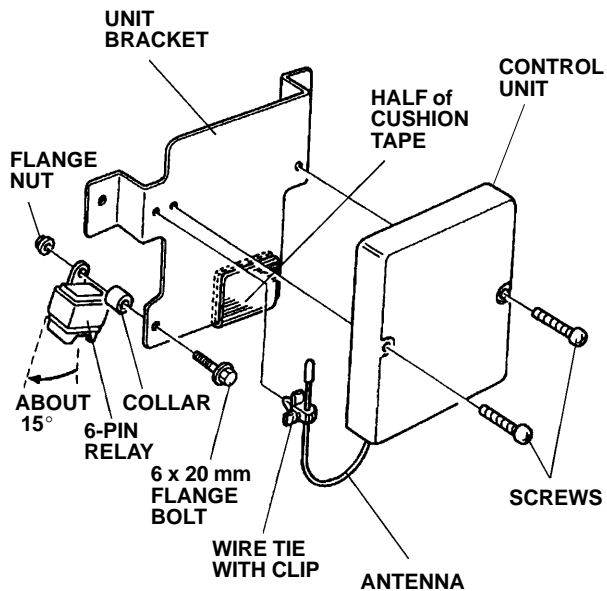

18. Attach the 4-pin and 6-pin relays to the relay brackets.

4-PIN RELAY

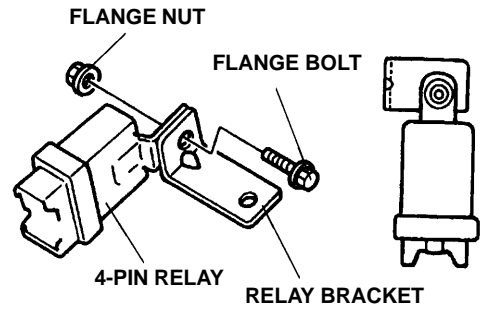

6-PIN RELAY

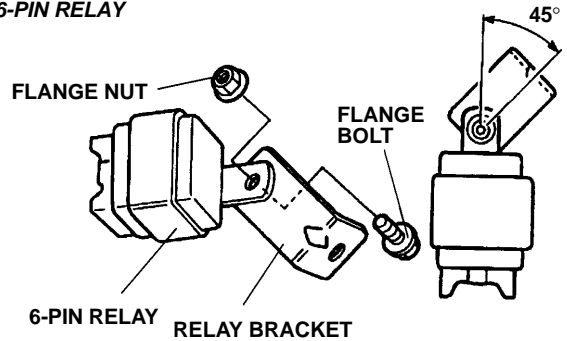

19. Locate the one 22-pin connector and two 6-pin connectors blue-taped to the vehicle harness, and remove the blue tape to free the connectors.

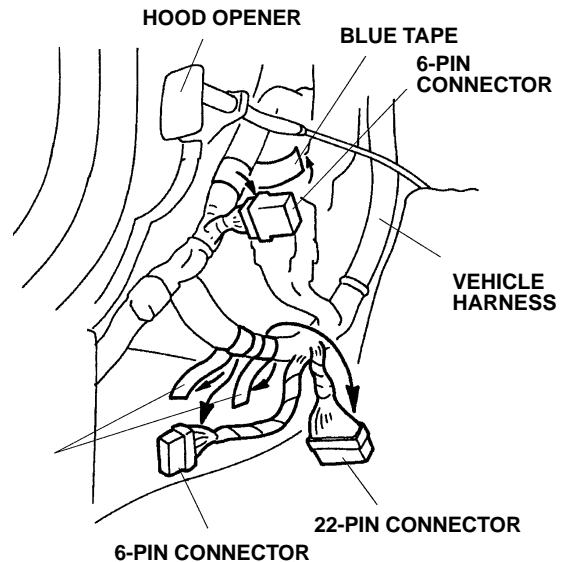

20. Install the unit bracket using two of the flange bolts from the kit.

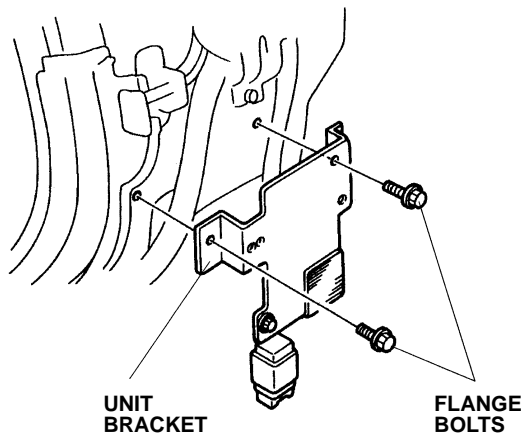

21. Attach the control unit onto the unit bracket by installing the two 4 x 30 mm washer-screws. Attach the wire tie with clip to the antenna, and press its clip into the hole in the unit bracket.

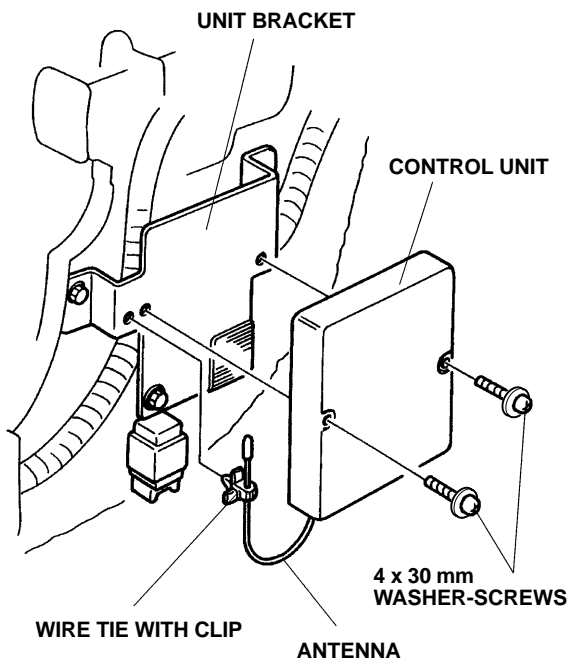

22. Locate the 6-pin and 22-pin connectors you freed from the vehicle harness in step 19, and plug the 22-pin connector into the control unit. Remove and discard the dummy connector from the 6-pin connector, then plug the vehicle 6-pin connector into the relay.

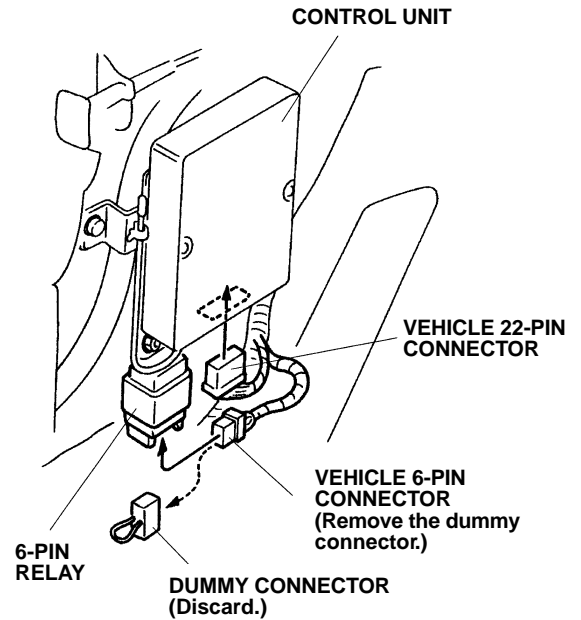

23. Above the control unit, remove the bolt fastening the key light unit, and locate the 2-pin connector blue-taped to the vehicle harness behind the black case. Remove the blue tape to free the connector, and plug the 2-pin connectors of the security system harness in between the connectors you just unplugged.

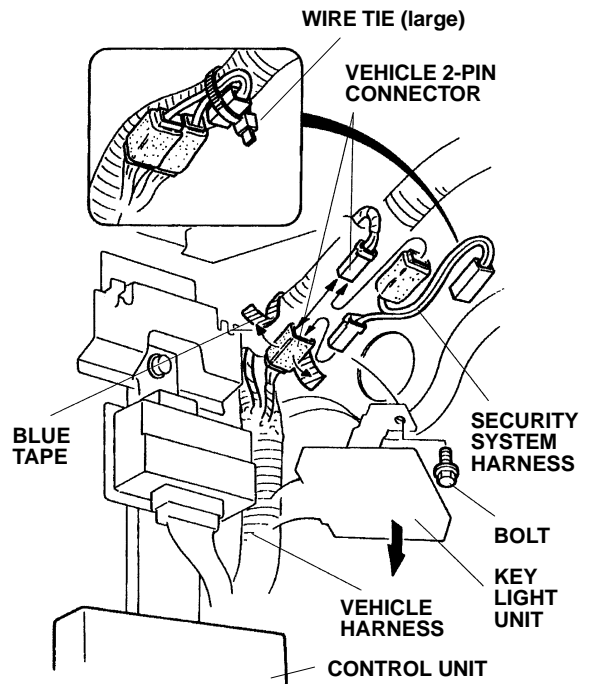

24. Fold the security system harness, and secure it to the vehicle harness with one large wire tie.
25. Remove the bolt attaching the top of the hood opener, and attach the 6-pin relay with this bolt. Note the installation direction of the 6-pin relay.

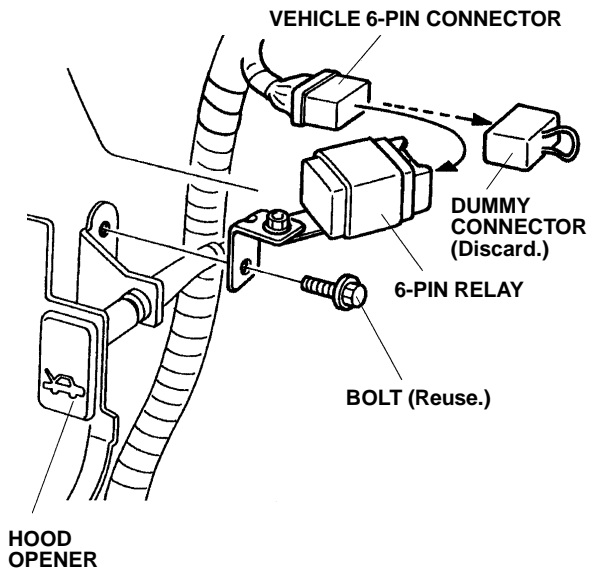

26. Remove and discard the dummy connector from the remaining vehicle 6-pin connector you freed in step 19, and plug the 6-pin connector into the relay.

27. Remove the bolt that fastens the knee bolster bracket on the left side, and use this bolt to attach the 4-pin relay (installed on the bracket in step 18) between the knee bolster bracket and the dashboard frame.

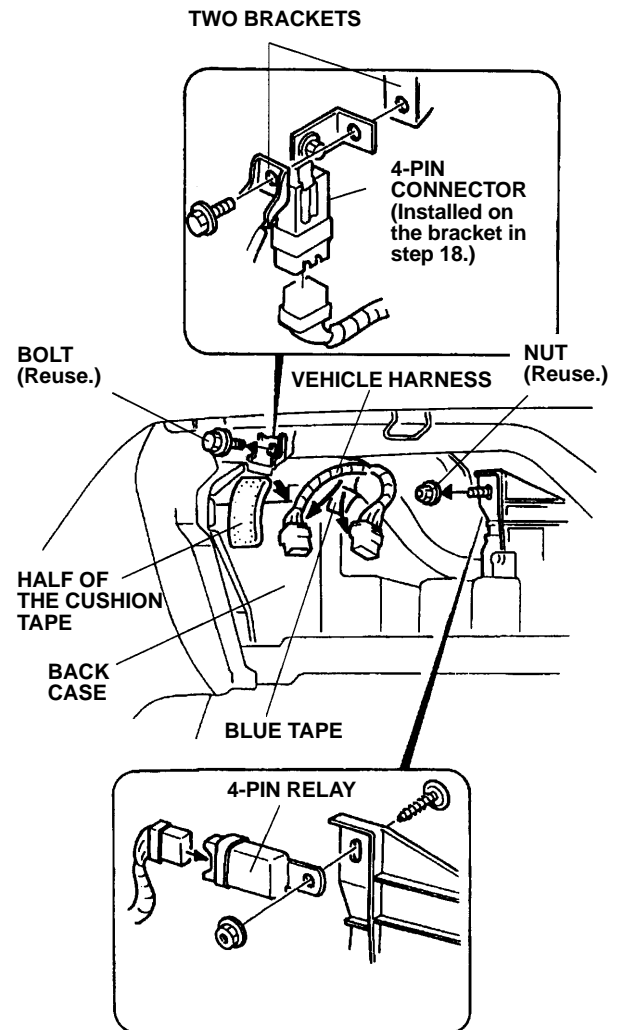

28. Remove the mounting nut from the upper left blower housing, and use this nut to attach the other 4-pin relay.
29. Inside the glove box opening, locate the 4-pin connectors blue-taped to the vehicle harness, and remove the blue tape to free the connectors.
30. Plug the two 4-pin connectors into the 4-pin relays installed in steps 27 and 28.

31. Plug the 3A fuse (provided) into the fuse box; the fuse goes in the slot (numbered 2) that is third from the left. Remove the two nuts fastening the fuse box, and pull the fuse box out toward you.

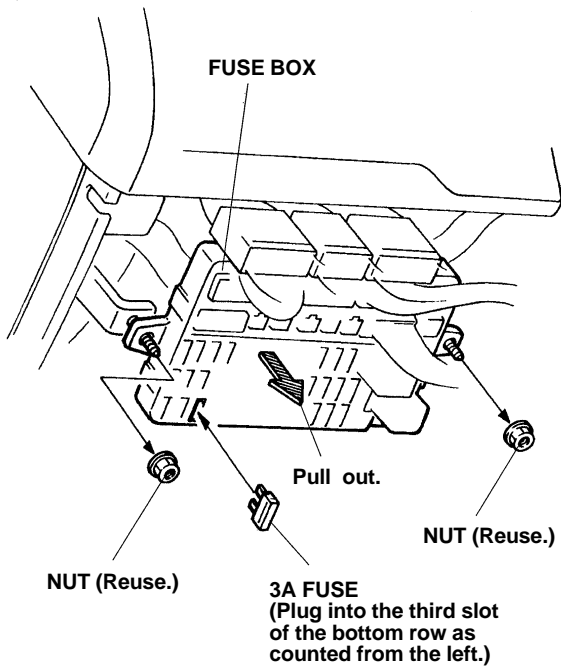

32. Open the fuse lid on the dashboard lower cover, and attach the fuse label in the area shown.

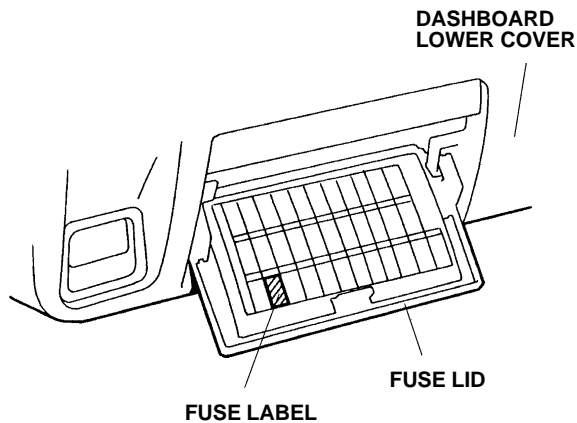

33. Above the fuse box, locate the 2-pin connector blue-taped to the vehicle harness, and remove the blue tape to free the connector.

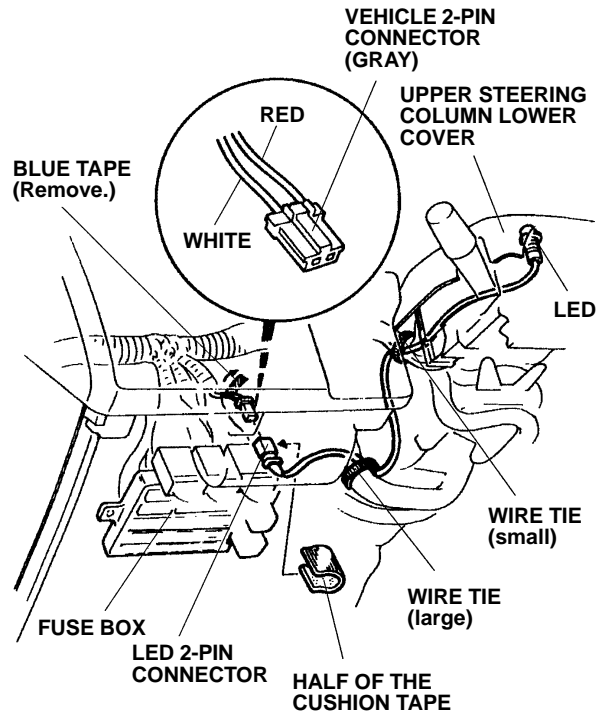

34. Behind the fuse box, locate the 3-pin connector blue-taped to the vehicle harness, and remove the tape to free the connector.

35. Install the upper steering column cover, then route and connect the LED harness to the 2-pin connector freed in step 33.

36. Secure the LED harness to the vehicle harness with the one half of the cushion tape and the remaining two wire ties in the areas shown. Make sure that the LED harness is not pinched.

37. Plug the 3-pin connector of the disarm switch harness into the 3-pin connector you freed in step 34; then reinstall the fuse box. Route the disarm switch harness above the left nut that secures the fuse box.

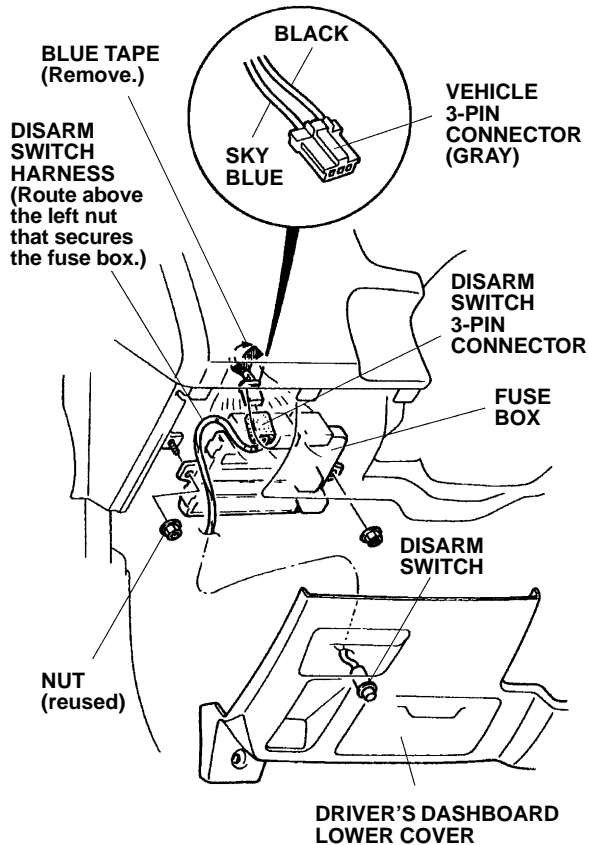

38. Reinstall the knee bolster.

39. Reinstall the driver's dashboard lower cover.

40. Check that all wire harnesses are routed properly and all connectors are plugged in.

41. Reinstall all removed parts.

42. Reconnect the negative cable to the battery.

43. If equipped, enter the customer's radio anti-theft code, and reset the radio station presets buttons

44. Reset the clock.

45. Check operation of the security system according to the Owner's Manual provided.