

HONDA INSTALLATION INSTRUCTIONS

Accessory
CASSETTE PLAYER

Application
2001 CR-V (EX)

Publications No.
All 21682
Issue Date
OCT 2000

PARTS LIST

Cassette Player Attachment: P/N 08B12-S10-100F

Right bracket

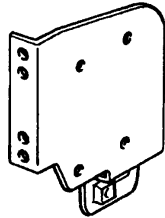

Left bracket

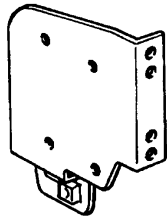

2 Wire clips



4 Washer-screws, 4 x 8 mm
(not used)



2 Washer-screws, 5 x 8 mm



2 Bolts, 5 x 10 mm
(not used)



Cassette Player (sold separately): P/N 08A03-5B1-050

Cassette player

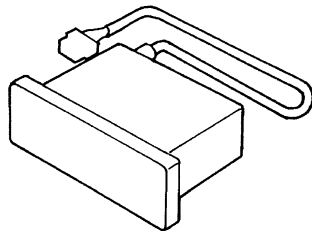

4 Washer-screws, 5 x 8 mm



Owner's Manual



Wire tie



TOOLS REQUIRED

Diagonal cutters
#2 Phillips screwdriver

INSTALLATION

Customer Information: The information in this installation instruction is intended for use only by skilled technicians who have the proper tools, equipment, and training to correctly and safely add equipment to your vehicle. These procedures should not be attempted by "do-it-yourselfers."

1. If equipped, make sure that you have the anti-theft code for the radio, then write down the frequencies for the preset buttons on the radio.
2. Slide the driver's seat completely to the rear.
3. Disconnect the negative cable from the battery.
4. Open the glove box. Squeeze the retaining tabs, and remove the stop. Pull the glove box down.

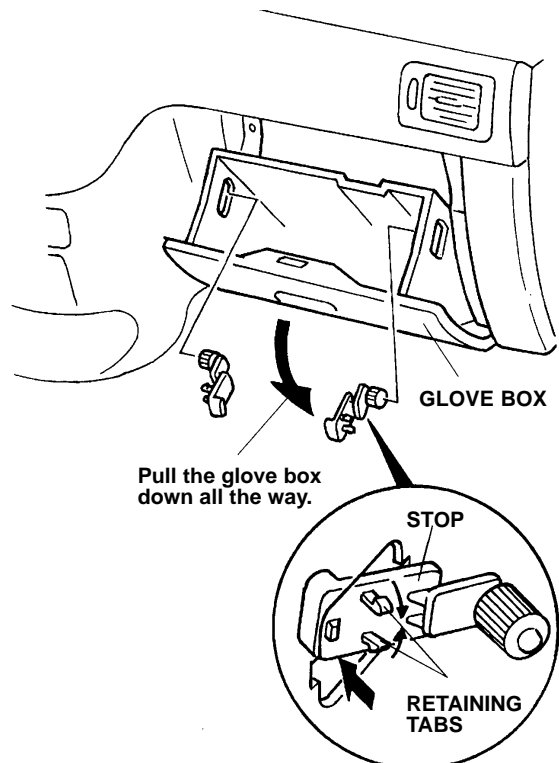

- Remove the driver's dashboard lower cover (two self-tapping screws, four retaining clips and one connector).

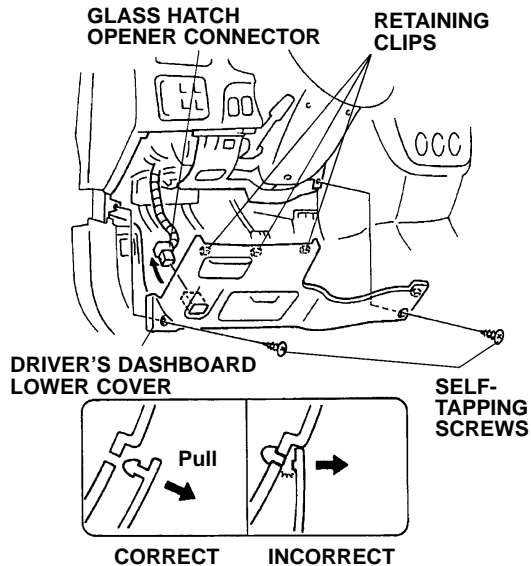

- Remove the lower console cover.

AT Model:

- Remove the two self-tapping screws attaching the right side of the center console.

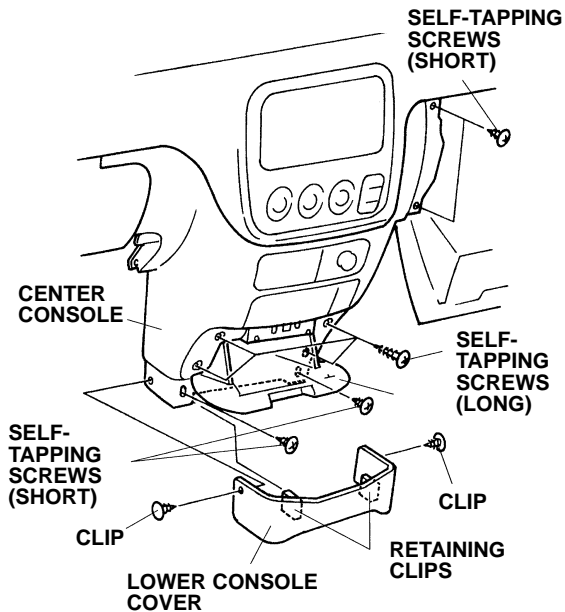

- Remove the two clips attaching the lower console cover, then remove the cover by pulling it toward you.
- Remove the two self-tapping screws from the bottom of the center console, open the console pocket, and remove the four self-tapping screws behind the pocket.

MT Model:

- Remove the change lever knob by sliding the boot down while pressing down on the two retaining tabs at the bottom of the knob, then by turning it counterclockwise.

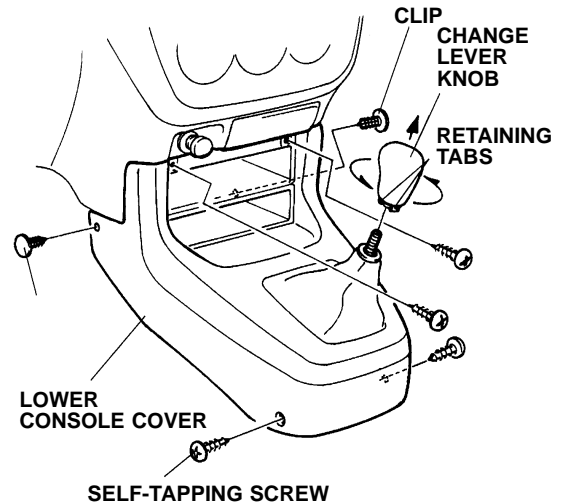

- Remove the four self-tapping screws and two clips fastening the lower center console cover and remove the console cover.
- Remove the four self-tapping screws securing the console pocket and remove the pocket.

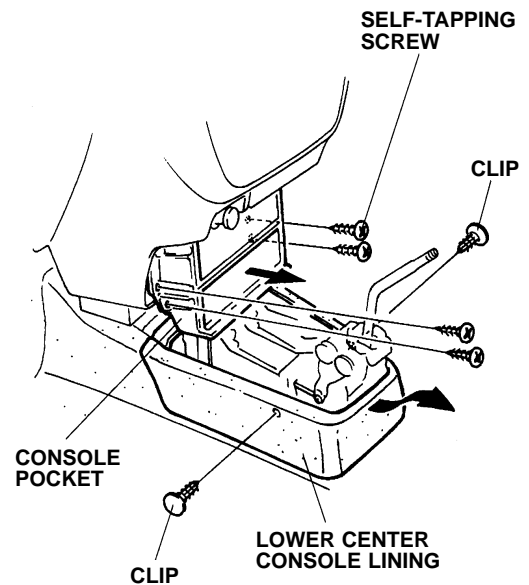

- Remove the two clips that fasten the lower center console lining and remove the lining by lifting it upward.

7. Remove the center dashboard lower cover.

AT Model: Gently pull the center dashboard lower cover toward you to release the three clips, then unplug the two connectors.

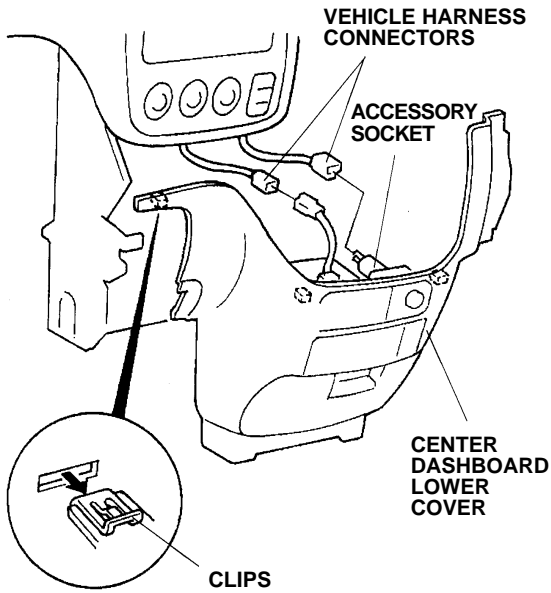

MT Model:

- Remove the five self-tapping screws fastening the center dashboard lower cover and pull the console out toward you to release the three retaining clips.

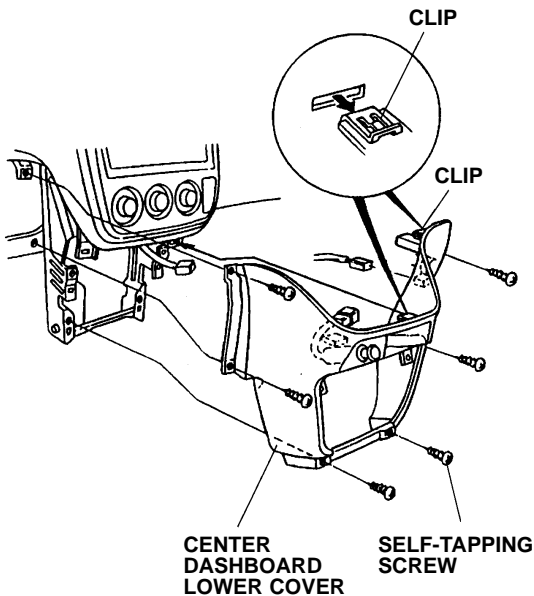

- Unplug the two connectors, and remove the center dashboard lower cover.

8. Remove and retain the two screws attaching the center panel, and remove the panel:

- Unplug the 16-pin connector and antenna lead from the radio.

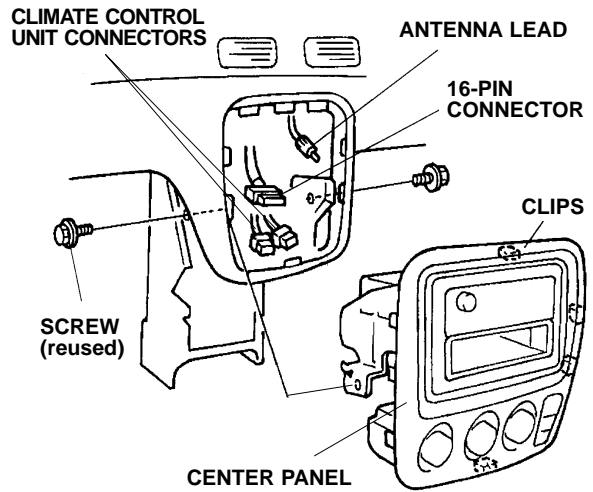

- Unplug the two connectors from the climate control unit.

9. Remove and retain the four washer-bolts that attach the radio to the center panel, then remove the radio.

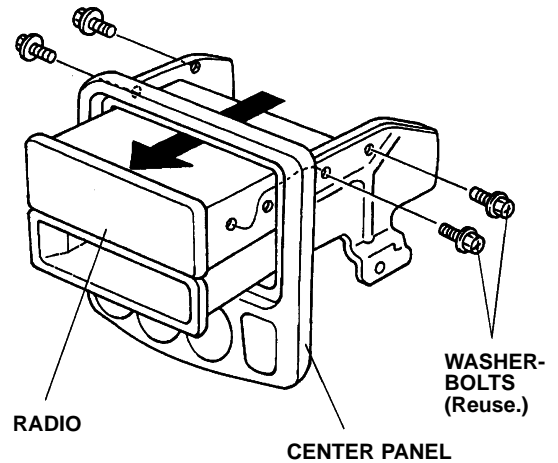

10. Separate the pocket from the radio by removing the two self-tapping screws.

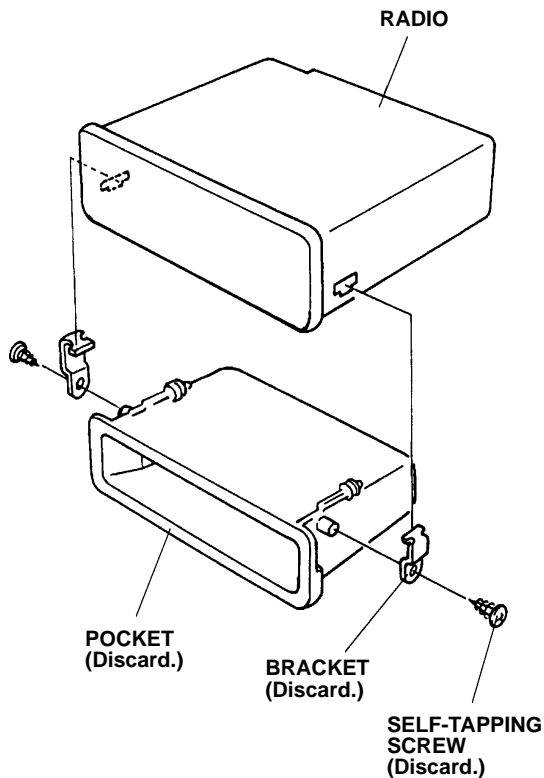

11. Remove the four self-tapping screws, and remove and discard the existing radio brackets from the center panel. Retain the four self-tapping screws.

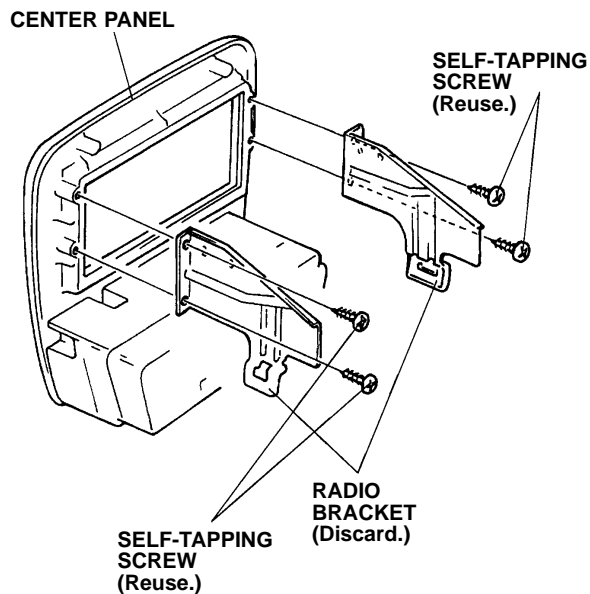

12. Attach the new left and right brackets to the center panel using the self-tapping screws removed in step 11.

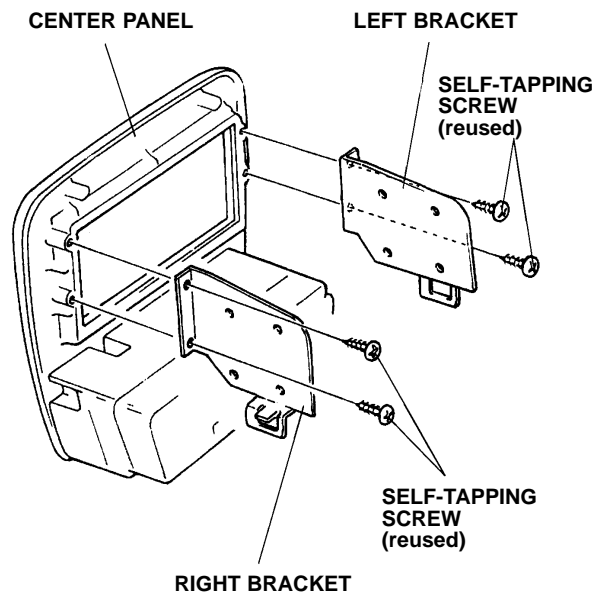

13. Place the radio onto the cassette player. Slide the radio assembly into the center panel, and install the eight washer-bolts (four removed in step 9, and four provided with the cassette player).

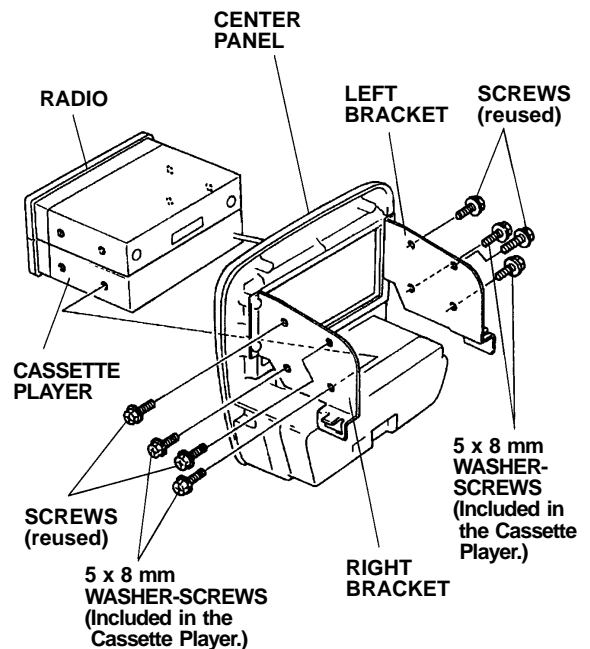

14. Install the clip to the rear of the cassette player with one washer-bolt.

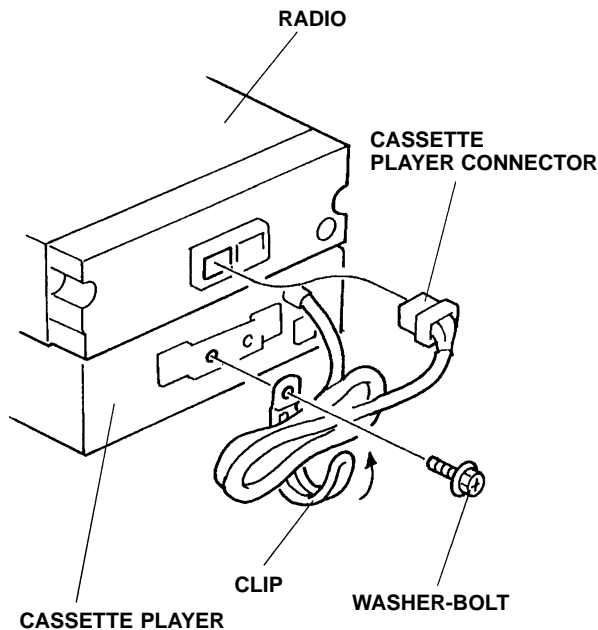

15. Plug the connector from the cassette player into the rear of the radio; then fold and secure the BUS cable with the wire clip.

16. Plug the antenna lead and the 16-pin connector into the rear of the radio, and install the center panel on the dash:
 - Check that the six retaining clips on the back of the center panel are not deformed or damaged. Noise may result if the clips are deformed and are not properly installed. Replace the clips if they are deformed or damaged:

- 4 Clips (small) P/N 90666-S10-003
- 2 Clips (large) P/N 90666-SD4-003

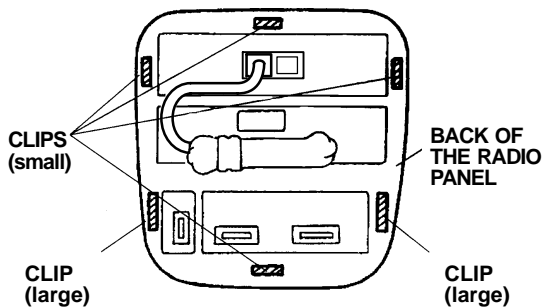

- Be sure to insert the retaining clips securely into the slots in the dash when installing the center panel on the dash.

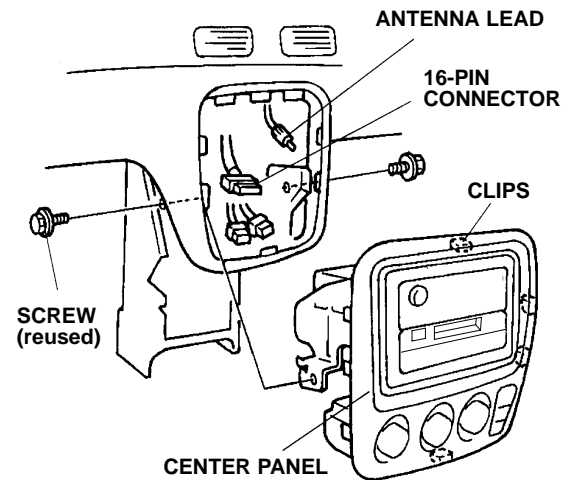

- Reinstall the two screws removed in step 8.

17. Reinstall all removed parts.

18. Check that all wire harnesses are routed properly and all connectors are plugged in.

19. Reconnect the negative cable to the battery.

20. If equipped, enter the customer's radio anti-theft code, and reset the radio station preset buttons.

21. Reset the clock.

22. Check that the cassette player operates properly according to the Owner's Manual that comes with the unit.