



**INSTALLATION  
INSTRUCTIONS**

Accessory

**FOG LIGHTS  
P/N 08V31-SCV-102**

Application

**2007-2008 ELEMENT**

Publications No.

**All 36531**

Issue Date

**MAY 2007**

**PARTS LIST**

2 Fog lights

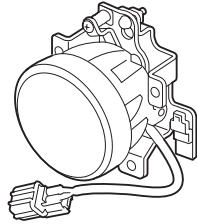

Switch harness

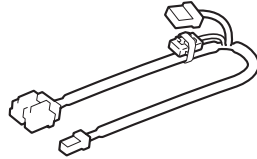

Fog light harness

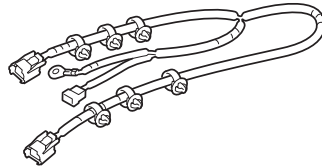

Relay bracket

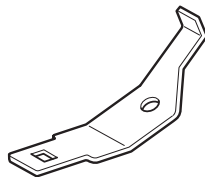

Relay

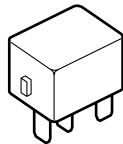

Fuse label

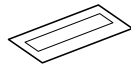

15 Wire ties

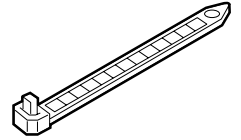

4 Wire ties with clip

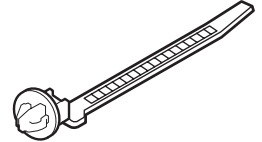

8 Self-tapping screws



Washer-bolt

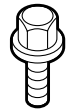

Flange nut



Switch

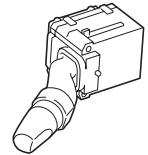

Clip

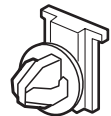

## TOOL AND SUPPLIES REQUIRED

Phillips screwdriver  
Flat-tip screwdriver  
Ratchet  
10 mm socket  
File  
Drill  
3 mm drill bit  
20 mm Hole saw  
Utility knife  
Pushpin  
Hacksaw blade  
Clip remover

### Illustration of the Fog Light Installed on the Vehicle

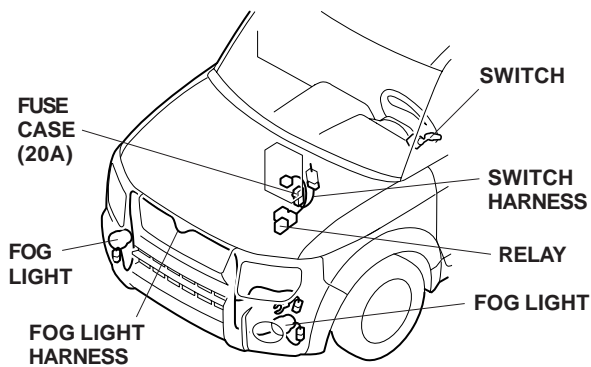

## INSTALLATION

**Customer Information:** The information in this installation instruction is intended for use only by skilled technicians who have the proper tools, equipment, and training to correctly and safely add equipment to your vehicle. These procedures should not be attempted by "do-it-yourselfers."

NOTE: These installation instructions show the left fog light being installed. The same procedure applies to installing the right fog light.

1. Make sure you have the anti-theft code for the radio, then write down the frequencies for the preset buttons.
2. Disconnect the negative cable from the battery.

## Installing the Fog Light

3. Open the hood and remove the radiator cover (five clips).

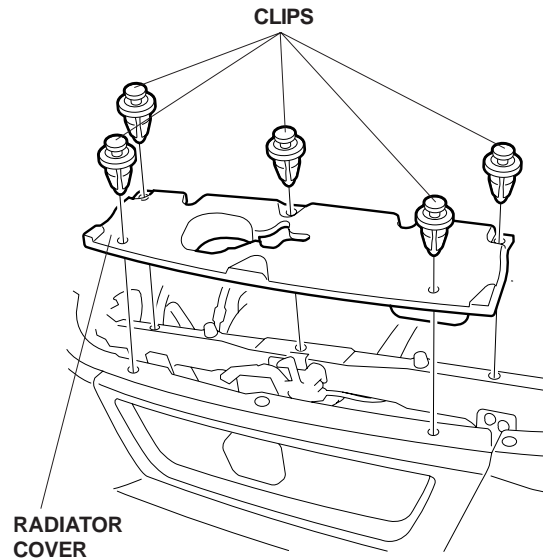

4. With the help of an assistant, remove the front bumper (seven clips at the top, six clips and four stepped bolts at the bottom and one self-tapping screw on each side). Put the bumper on a blanket to protect the finish.

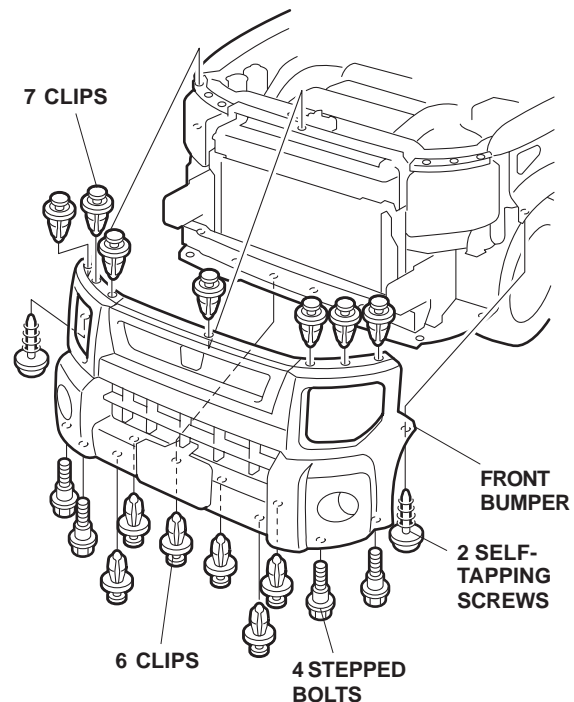

- Inside the front bumper, locate the three marks on the fog light housing on the left side. Using a pushpin, pierce the bumper at the center of each mark. While wearing eye protection, drill a 3 mm pilot hole then finish with a 20 mm hole through the bumper at the center of each mark.

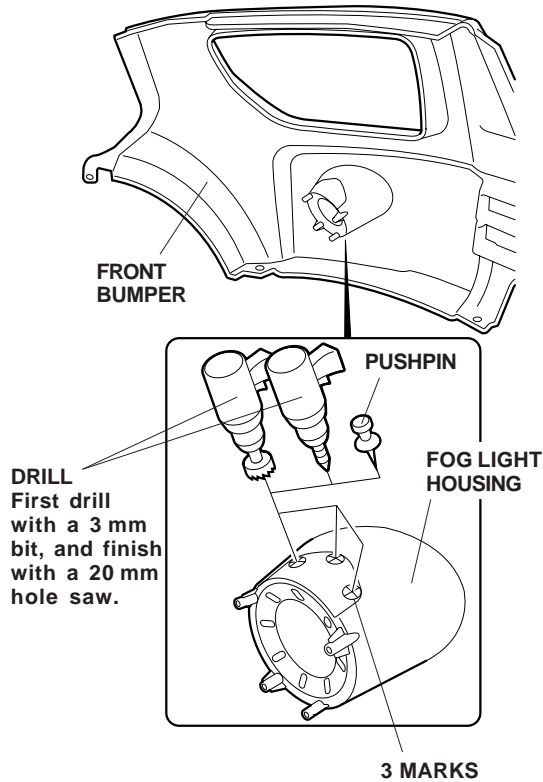

- Using a hacksaw blade, cut out the marked area from the front bumper along the inside of the scribed line and the groove on the back. Remove all burrs from the edges of the cutout.

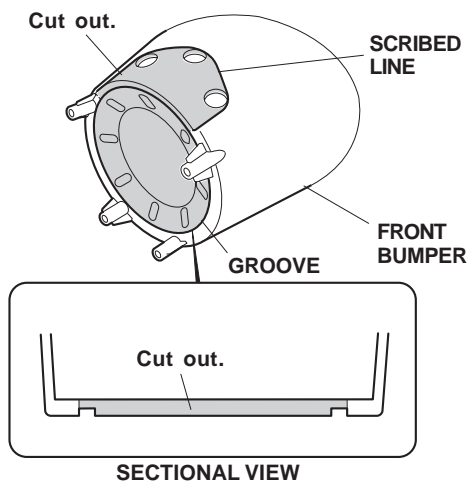

- Inside the front bumper, slide the fog light into the cutout you made, and secure it with four self-tapping screws.

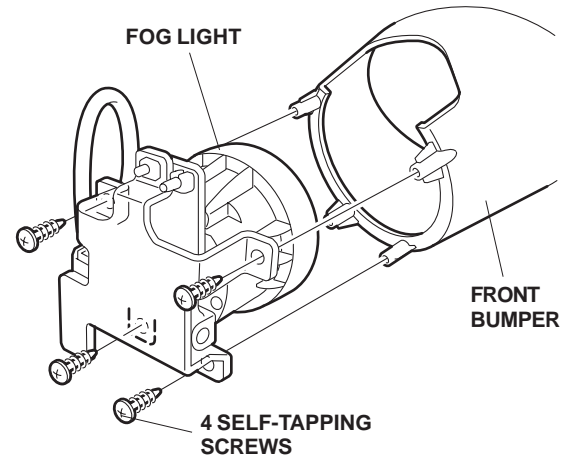

- Repeat steps 5 thru 7 to cut the bumper and install the fog light on the right side of the bumper.

### Routing the Fog Light Harness

- Starting under the left headlight, route the fog light harness 1-pin connector and ground terminal through the hole in the front bulkhead.

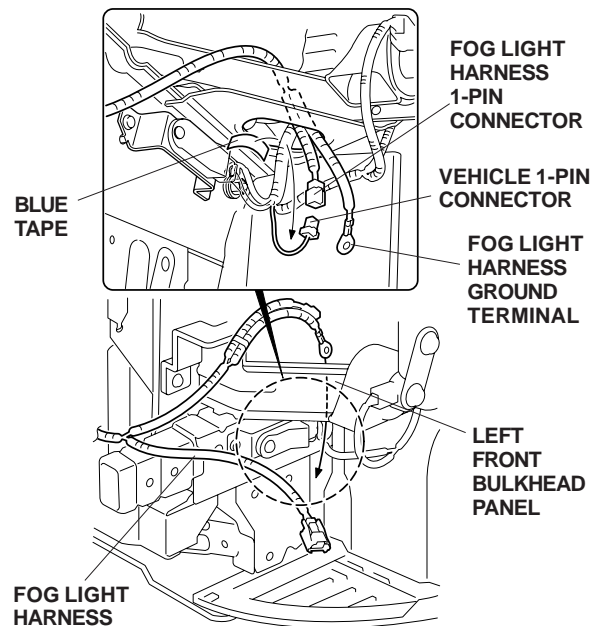

- Locate the 1-pin connector blue-taped to the vehicle harness and remove the blue tape to free the 1-pin connector. Connect the 1-pin connector you just freed to the fog light harness 1-pin connector.

11. Remove the ground bolt that fastens the vehicle ground terminal and secure the fog light harness ground terminal using this ground bolt.

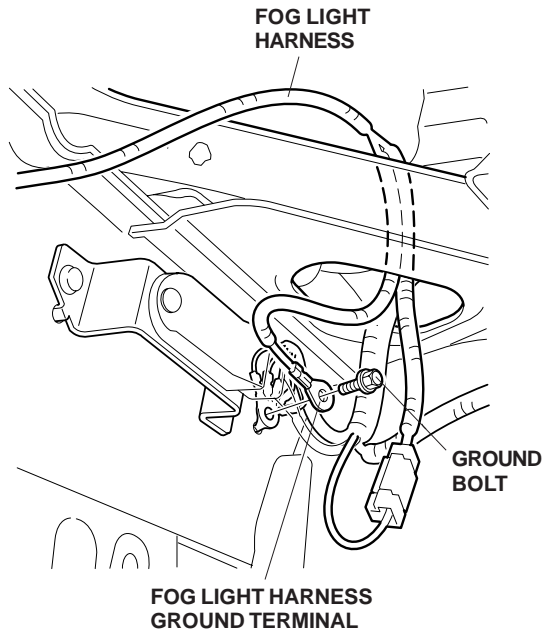

12. Secure the fog light harness 1-pin connector and the fog light harness to the vehicle harness with one wire tie. Do not secure the 1-pin connector to the SRS harness with the wire tie.

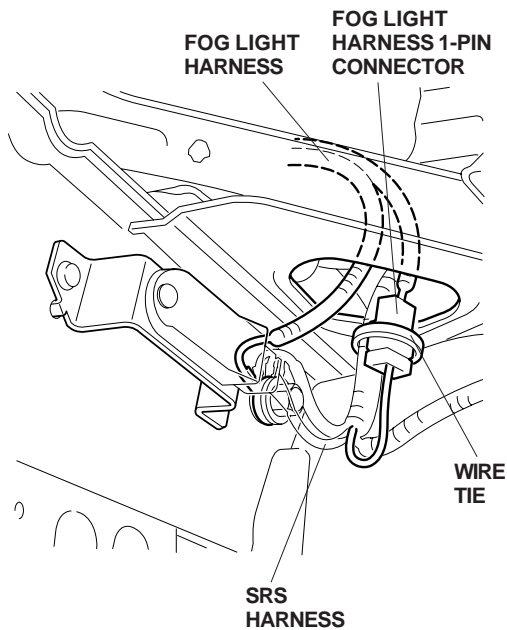

13. Behind the front side frame, route the fog light harness 2-pin connector (short end) down, and out through the clearance between the side frame and front bumper beam. Attach the wire tie with clip on the fog light harness into the hole in the side frame.

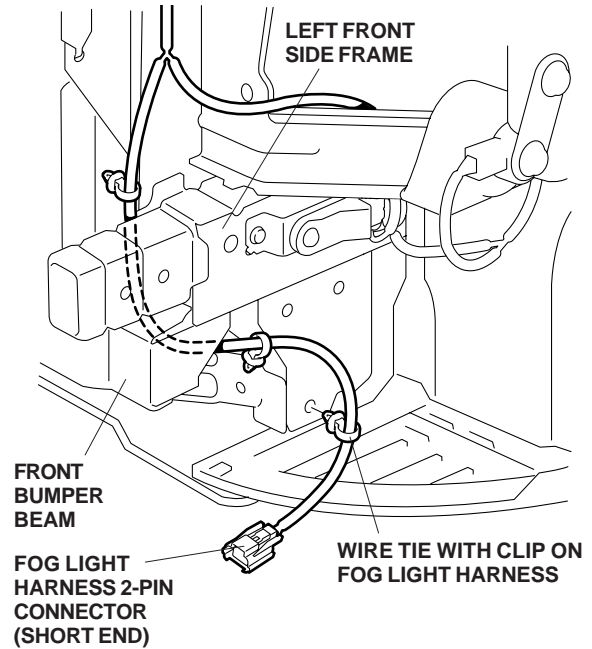

14. Route the fog light harness 2-pin connector (long end) up along the bulkhead side stay, then along the vehicle harness behind the front bulkhead upper frame.

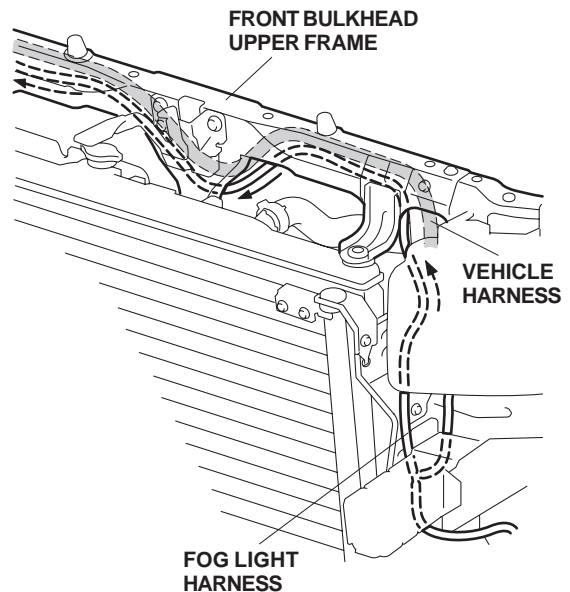

- Continue routing the fog light harness 2-pin connector forward, then down to the bottom of the front side frame along the outside of the right bulkhead side stay.

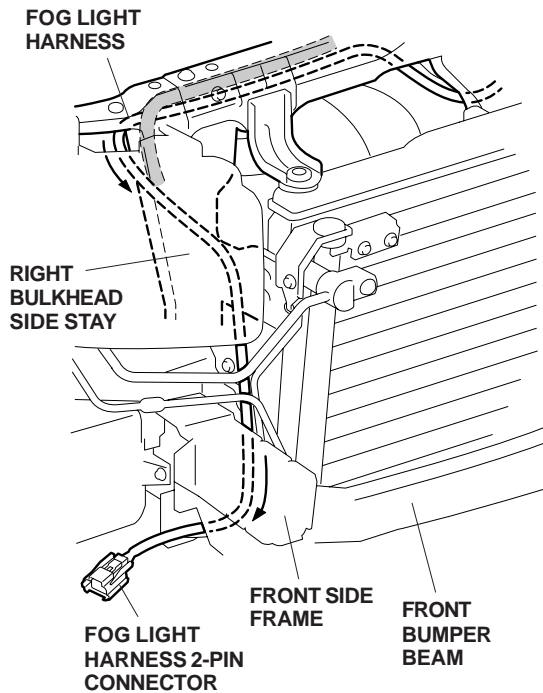

- Attach the three wire ties with clip on the fog light harness into the holes in the bulkhead side stay. Further secure the fog light harness to the vehicle harness with two wire ties in the areas shown without engine block heater.

**Without Engine Block Heater**

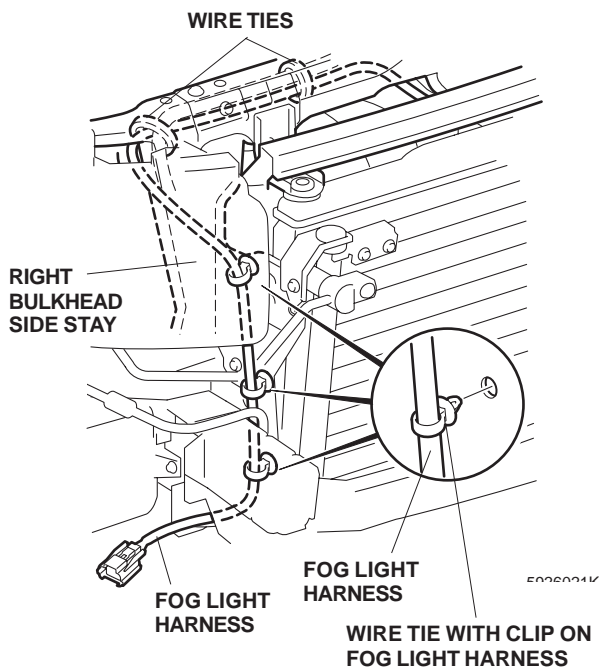

**With Engine Block Heater:**

Secure the engine block heater harness to the fog light harness with two wire ties as shown.

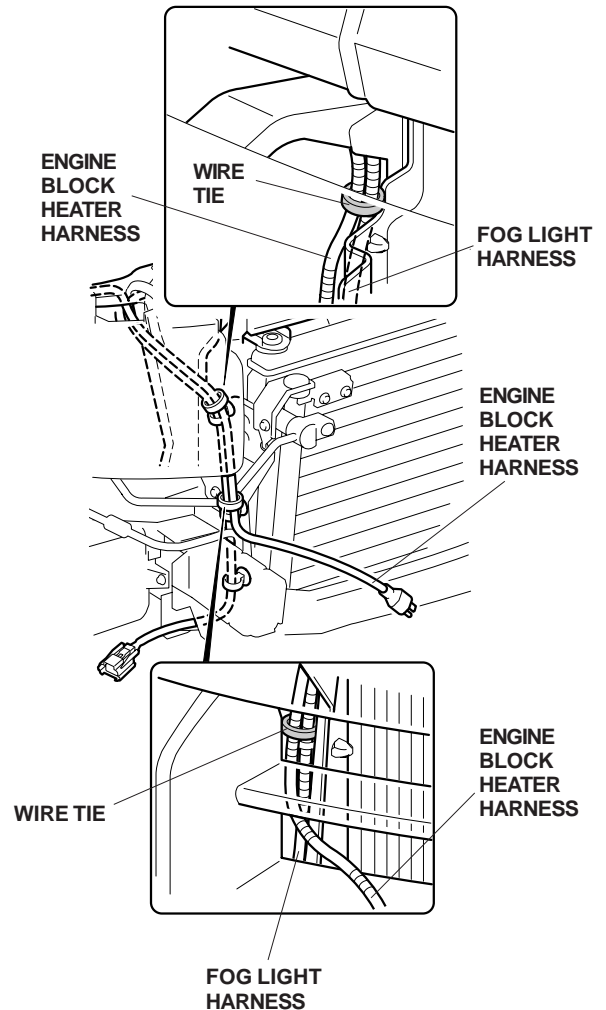

17. Secure the fog light harness to the hole with the wire tie as shown.

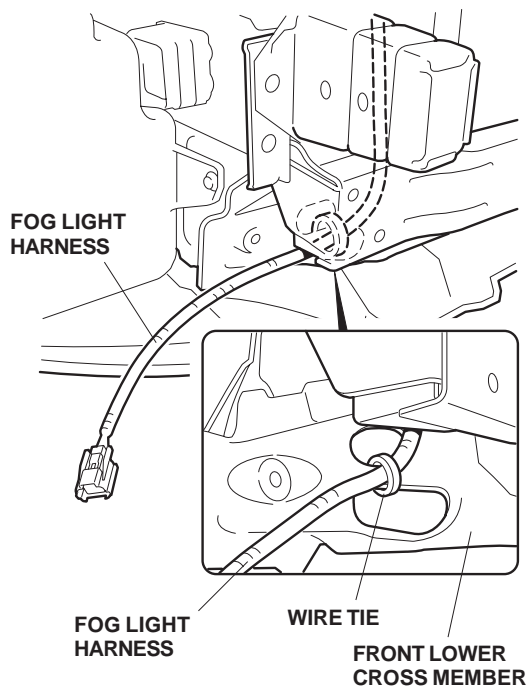

18. Secure the fog light harness to the holes in the bulkhead side stay and the left front bulkhead with the four wire ties with clip.

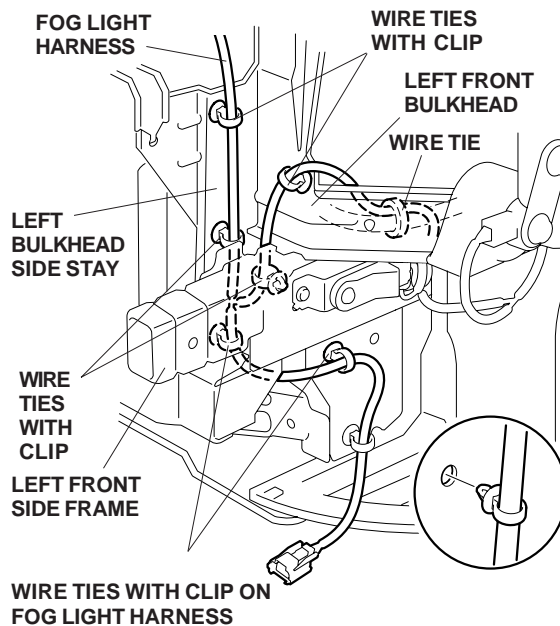

19. Secure the fog light harness to the vehicle harness with one wire tie.
20. Attach the two wire ties with clip on the fog light harness into the holes under the front side frame and the bulkhead side stay.
21. Secure the fog light harness to the vehicle harness with six wire ties.

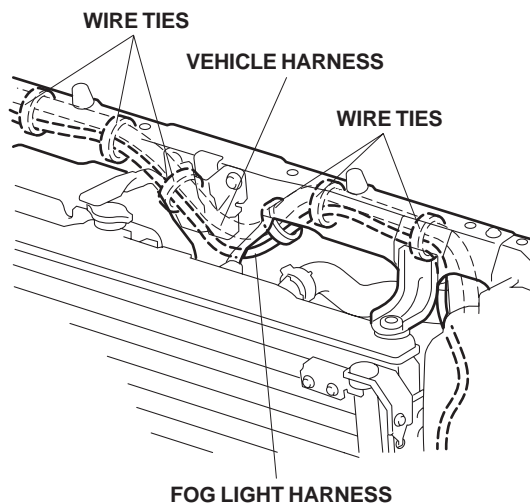

22. While holding the front bumper near the front of the vehicle, plug the fog light harness 2-pin connectors into the 2-pin connectors from the fog lights. Reinstall the front bumper.

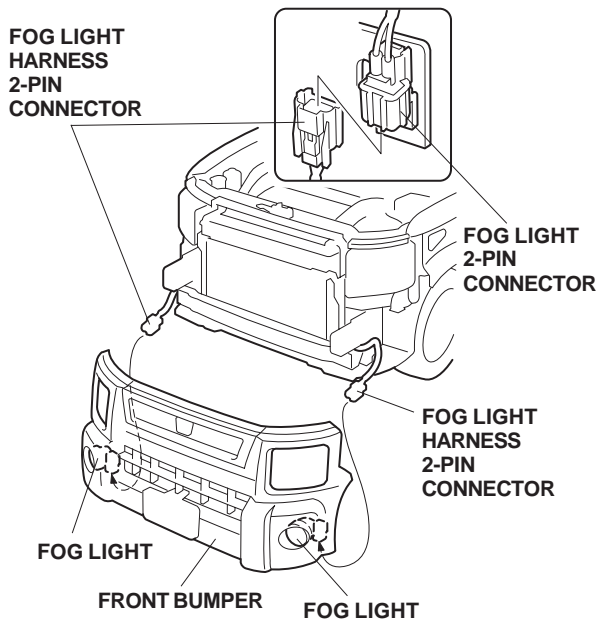

### Routing the Switch Harness

23. Remove the driver's dashboard lower cover, turn the knobs clockwise, then pull the cover out toward you to release the six retaining tabs.

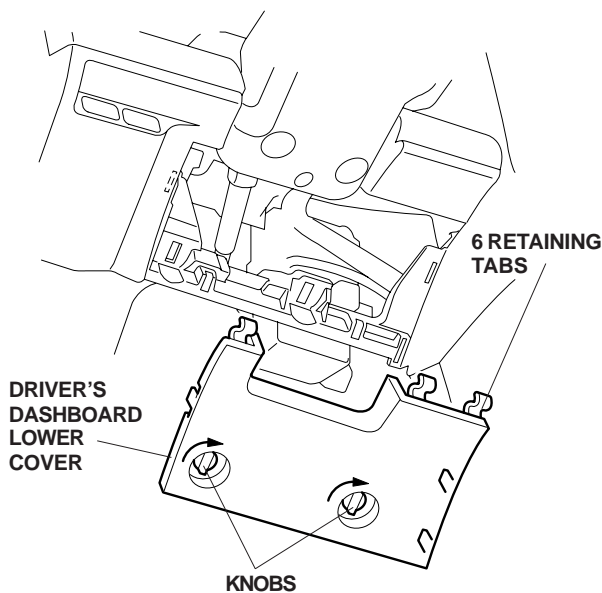

24. Lower the steering wheel using the tilt lever. Remove the two self-tapping screws and one washer-screw from the lower steering column cover.

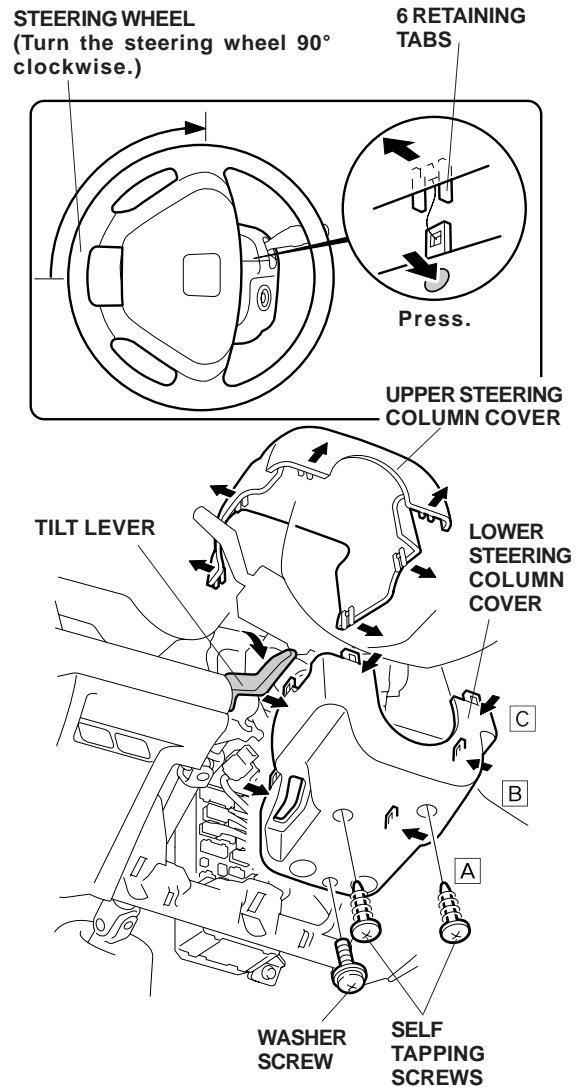

25. Separate the upper steering column cover from the lower steering column cover.
- Turn the steering wheel 90° clockwise, and press the point **A** to release the retaining tab.
  - Press point **B** and then **C** to release the retaining tabs. Once these retaining tabs are released, the retaining tabs on the opposite side will release.

26. Slide the relay bracket onto the switch harness relay block.

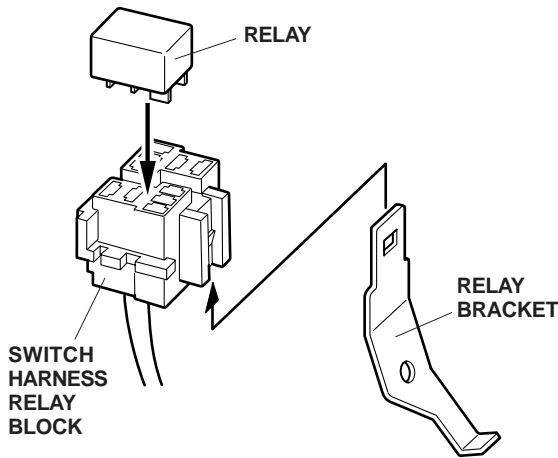

27. Slide the relay onto the switch harness relay block.
28. Under the dashboard, install the relay bracket on the data link connector bracket using a washer-bolt and flange nut.

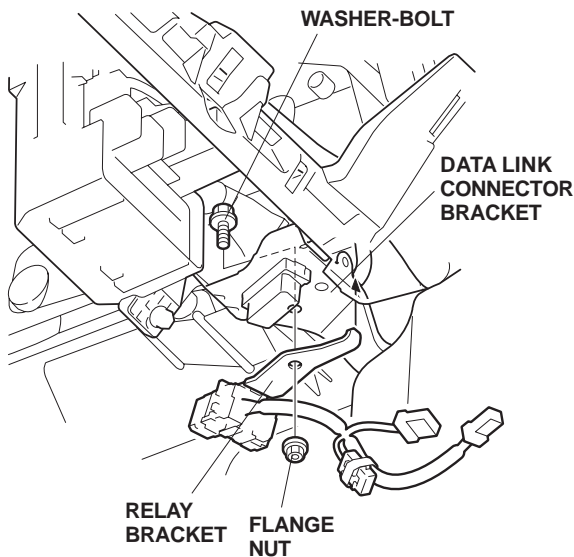

29. Locate the 3-pin connector blue-taped to the vehicle harness and remove the blue tape to free 3-pin connector. Slide the clip (supplied) onto the 3-pin connector you just freed.

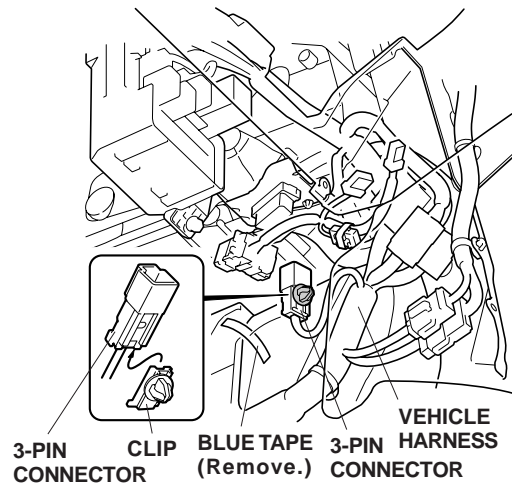

30. Attach the (20A) fuse label to the switch harness fuse case.

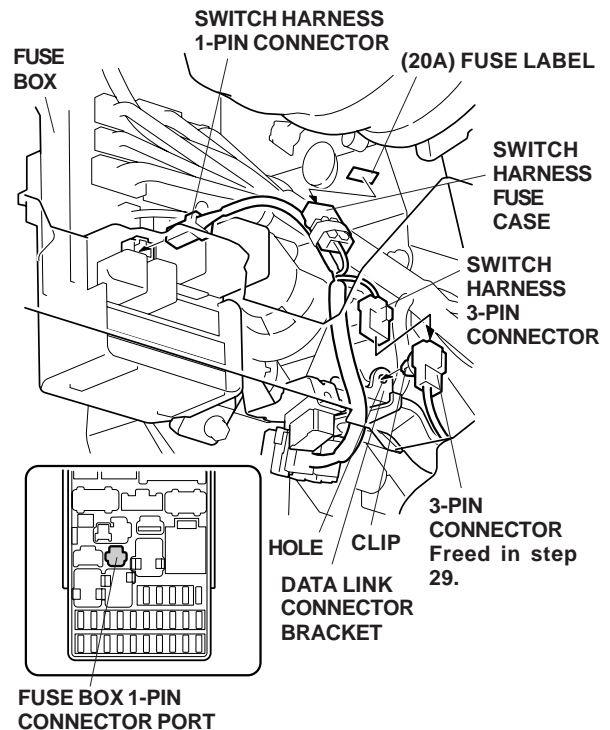

31. Plug the switch harness 1-pin connector into the fuse box in the location shown.
32. Plug the switch harness 3-pin connector into the 3-pin connector freed in step 29. Push the clip into the hole shown.

33. Secure the switch harness to the vehicle harness with two wire ties.

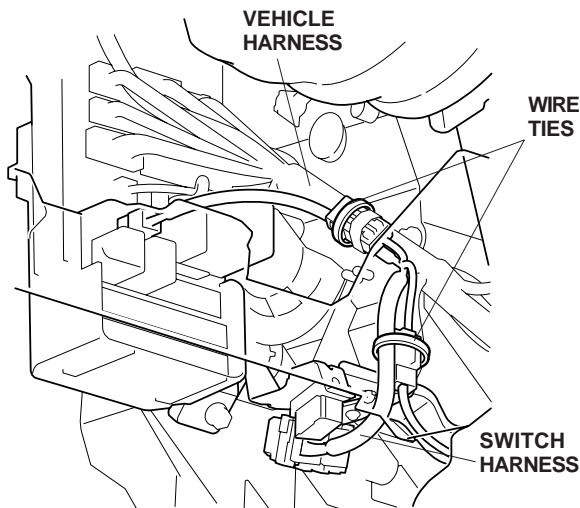

34. Turn the steering wheel 90° counterclockwise.

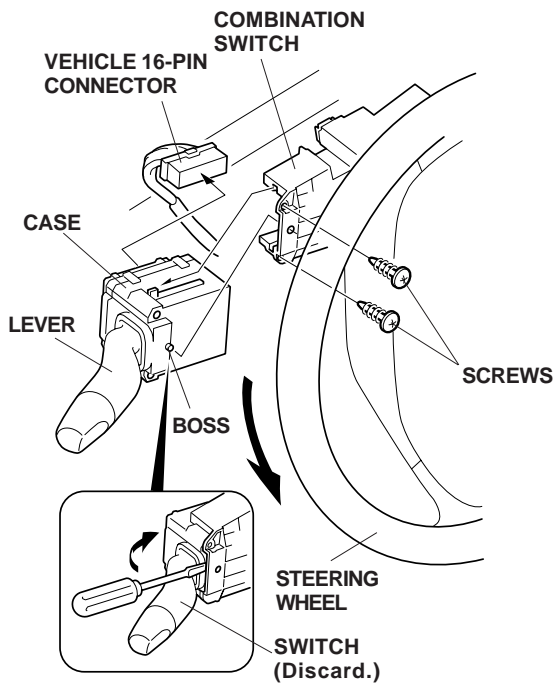

35. Unplug the vehicle 16-pin connector from the switch. Remove the two screws from the switch.
36. Pry off the boss by inserting the end of a flat-tip screwdriver between the combination switch and switch, then moving in the direction shown. Remove the switch from the combination switch. Hold the case when removing the vehicle switch. Do not hold the water lever.

37. Install the new switch where the old switch was removed. Then plug the vehicle 16-pin connector to the new switch. Hold the case when installing the switch. Do not hold the lever.

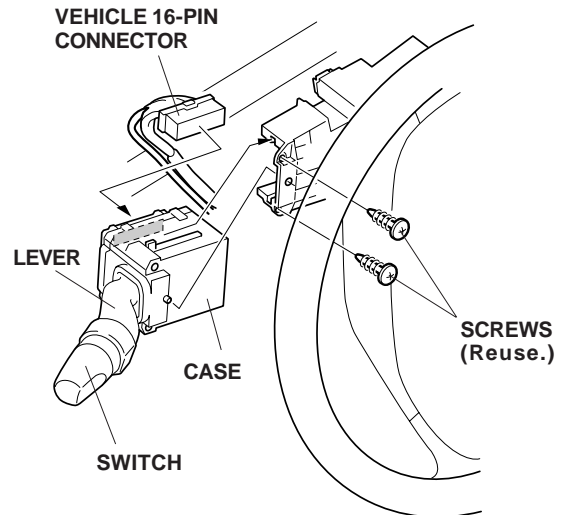

38. Check that all wire harnesses are routed properly and all connectors are plugged in.
39. Reinstall all removed parts. Check that all clips and fasteners are installed securely.
40. Reconnect the negative cable to the battery.
41. Reset the clock, and reset the radio station presets.

NOTE: When the battery is disconnected, the driver's window AUTO function is disabled.

- Start the engine. Push down on the driver's window switch until the window is fully open.
- Pull up on the driver's window switch to close the window completely, then hold the switch for 1 second or more.
- Lower and raise the window to check operation of the driver's window AUTO function.

## USE AND CARE

### How to Operate Fog Lights

- Turn the light switch to the “**D**” position (headlights on low beam).
- Turn the fog light switch (indicator “**F**” in the meter come on).

NOTE: The fog light lenses can cloud when the outside temperature is cold; this is normal and should go away in warm weather.

- If the fog lights do not come on, check the fuse and all connectors, including the ground cable.

### Fog Light Aiming Adjustment

- Adjust the aiming according local laws and regulations.
- To adjust, turn the aiming adjustment screw in or out until the correct aiming is obtained.

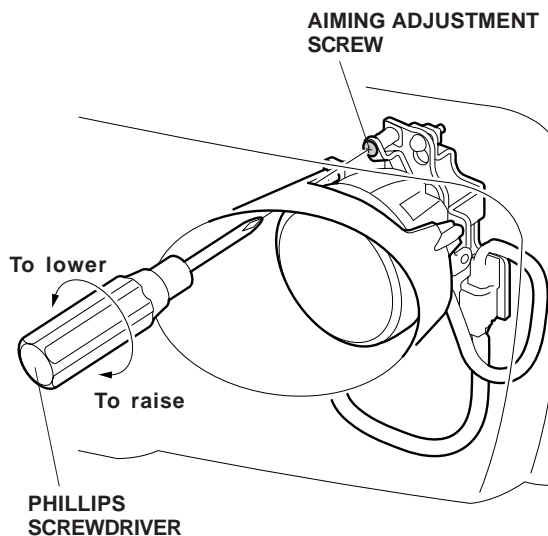

### Replacing the Fog Light Bulb

1. Loosen the upper right screw on the fog light. Lift the fog light up, then pull it out toward you.

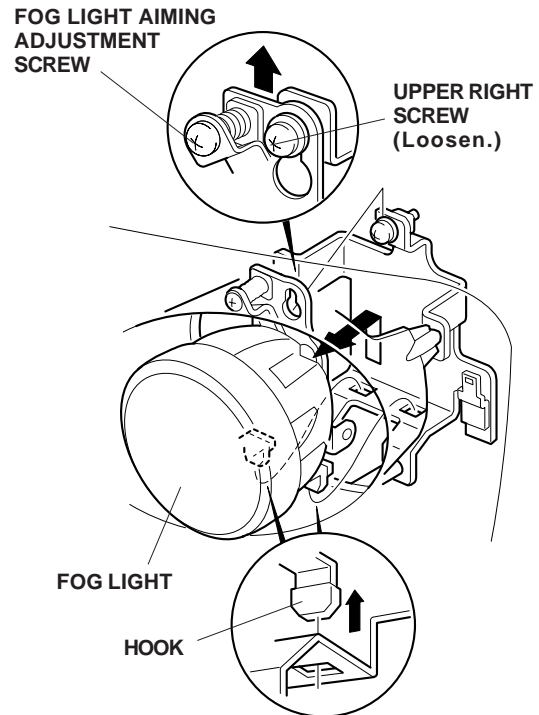

2. Remove the fog light connectors from the bracket stay, then unplug the connectors. Remove the fog light.

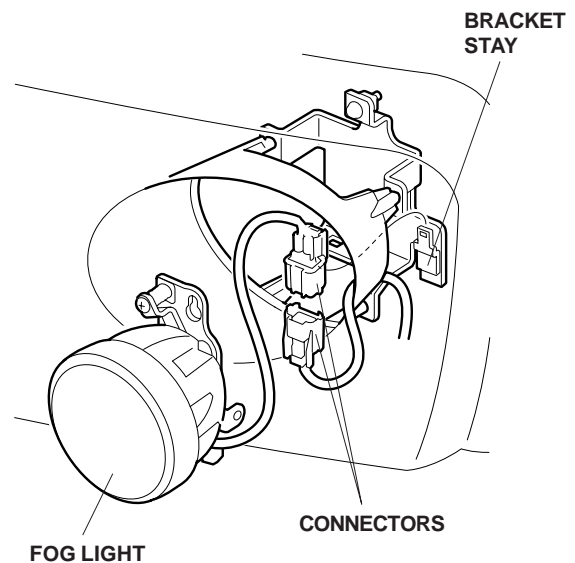

3. Remove the fog light rear cover (five screws).

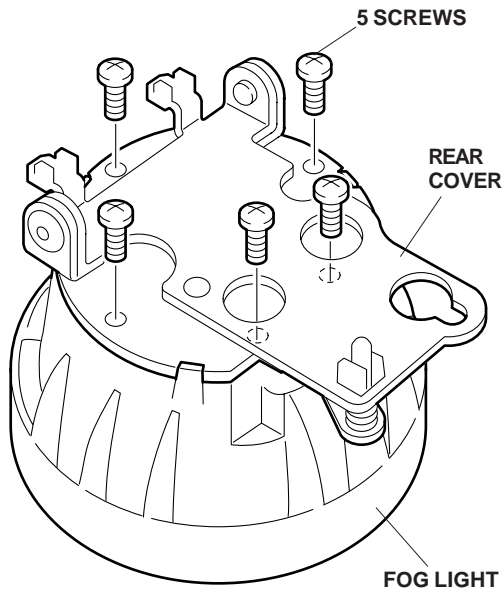

4. Remove the retainer spring, and pull out the bulb and socket as a unit.

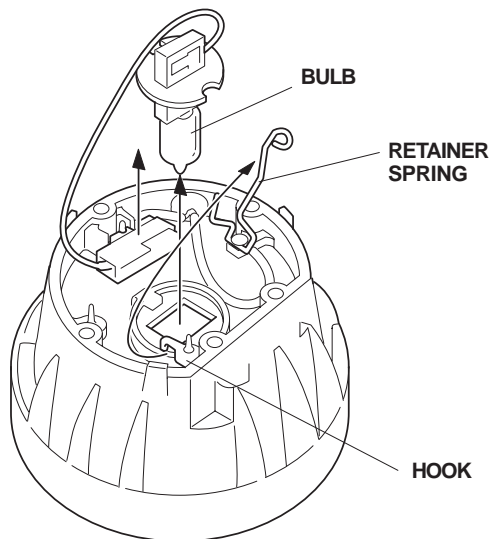

5. Install the new bulb into the socket.

- Use only a genuine Honda halogen light bulb of specified wattage.

Rating: 12V 55W H3 Halogen Light Bulb  
P/N 33165-SB0-7310-M1

- Do not touch the bulb. Oily or greasy substances on the bulb can shorten its service life due to the heat produced when the bulb is turned on. If the bulb is accidentally touched, wipe it clean with a soft cloth that has been dampened with denatured alcohol or a mild detergent solution.
- Align the tab on the fog light with the cutout in the bulb when installing the new bulb. If not aligned, the fog light may annoy oncoming drivers.

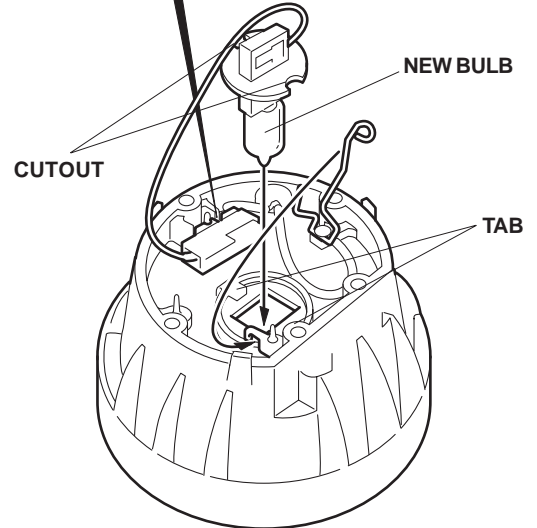
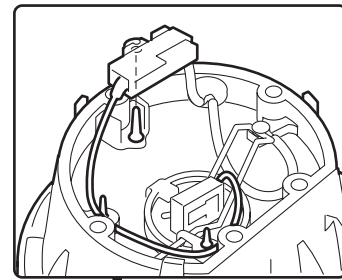

6. Reinstall the removed parts in the reverse order of removal.

- Check that the wire harnesses are not pinched.
- Make sure to tighten the screws securely.

**CIRCUIT DIAGRAM**

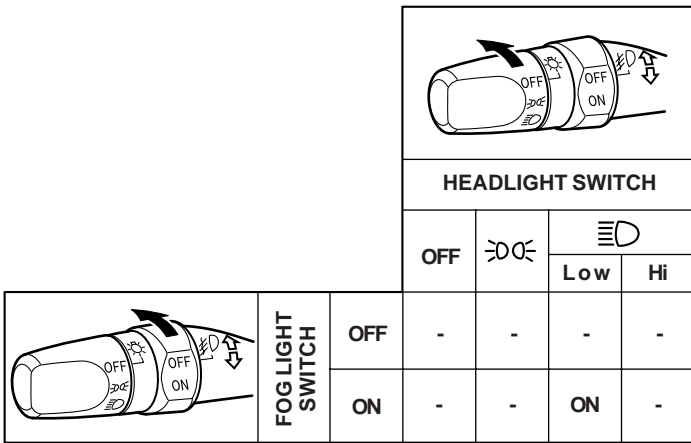
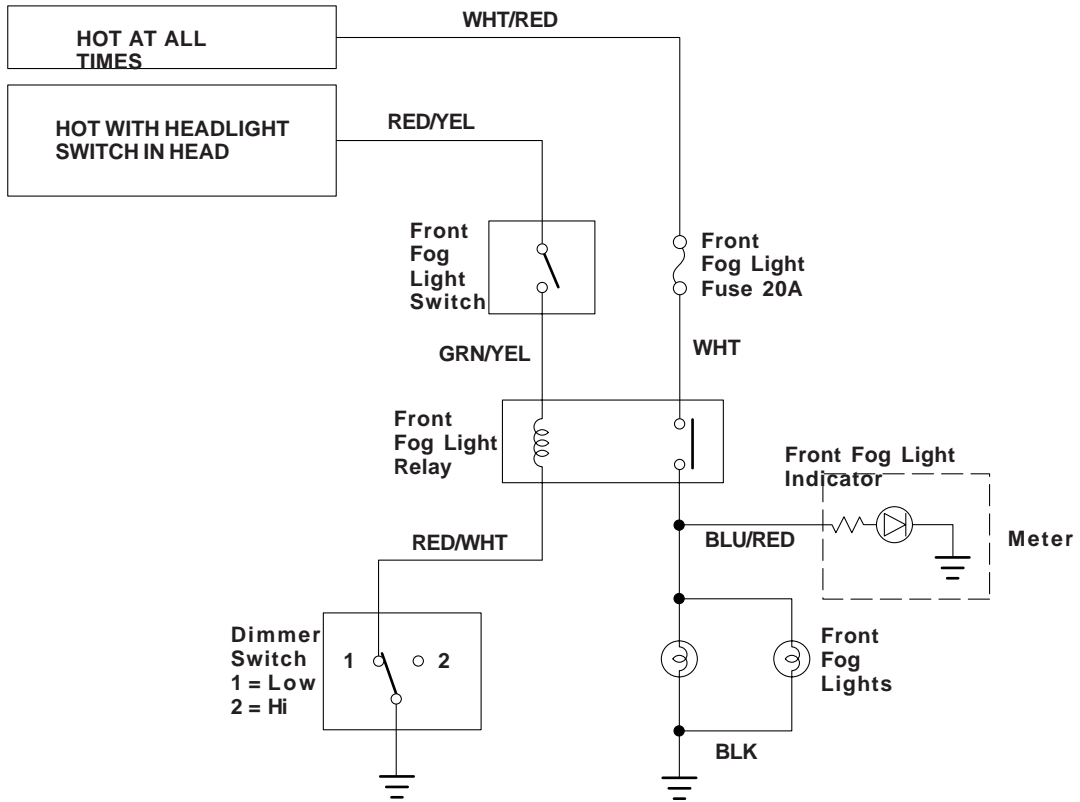

BLK	BLACK	BRN	BROWN
YEL	YELLOW	ORN	ORANGE
BLU	BLUE	PUR	PURPLE
GRN	GREEN	NAT	NATURAL
RED	RED	PNK	PINK
WHT	WHITE	GRY	GRAY
LT BLU	LIGHT BLUE	LT GRN	LIGHT GREEN